



County Hall  
Cardiff  
CF10 4UW  
Tel: (029) 2087 2000

Neuadd y Sir  
Caerdydd  
CF10 4UW  
Ffôn: (029) 2087 2000

## AGENDA

<b>Committee</b>	GOVERNANCE AND AUDIT COMMITTEE
<b>Date and Time of Meeting</b>	TUESDAY, 23 JANUARY 2024, 4.30 PM
<b>Venue</b>	COMMITTEE ROOM 4 - MULTI LOCATION MEETING
<b>Membership</b>	Gavin McArthur (Chairperson) David Price, Dr. Janet Wademan, Chris Burns,  Councillors Ahmed, Carr, Goodway, Lewis, Moultrie, Palmer and Williams

*Time approx.*

- |            |  |         |
|------------|--|---------|
| <b>1</b>   | <b>Apologies for Absence</b>   | 4.30 pm |
|            | To receive apologies for absence.  |         |
| <b>2</b>   | <b>Declarations of Interest</b>  |         |
|            | To be made at the start of the agenda item in question, in accordance with the Members' Code of Conduct. |         |
| <b>3</b>   | <b>Minutes</b> ( <i>Pages 5 - 14</i> )   |         |
|            | To approve as a correct record the minutes of the meeting held on 28 November 2023.                      |         |
| <b>4</b>   | <b>Directorate Control Environment Update</b> ( <i>Pages 15 - 54</i> )                                   | 4.40 pm |
|            | Andrew Gregory – Update on Directorate Control Environment for Planning, Transport and Environment       |         |
| <b>5</b>   | <b>Finance</b>   | 5.05 pm |
| <b>5.1</b> | Financial Update including Resilience Issues ( <i>Pages 55 - 60</i> )                                    |         |
| <b>6</b>   | <b>Internal Audit</b>  | 5.20 pm |
| <b>6.1</b> | Audit and Investigation Team - Progress Update ( <i>Pages 61 - 96</i> )                                  |         |

*This document is available in Welsh / Mae'r ddogfen hon ar gael yn Gymraeg*

6.2	Draft Internal Audit Charter & Summary Audit Plan 2024/25 (Pages 97 - 128)	
7	<b>Audit Wales</b>	5.40 pm
7.1	AW Work Programme and Timetable Update (Pages 129 - 144)	
7.2	Use of Performance Information: Service User Perspective and Outcomes - Cardiff Council Report (Pages 145 - 162)	
7.3	Digital Strategy Review: Cardiff Council Report (Pages 163 - 224)	
8	<b>Performance</b>	6.05 pm
8.1	Council Complaints – Mid Year Report (Pages 225 - 258)	
8.2	Mid-Year Self-Assessment Report Update (Pages 259 - 262)	
9	<b>Governance and Risk Management</b>	6.25 pm
9.1	Draft Annual Governance Statement 2022/23 (Pages 263 - 294)	
10	<b>Outstanding Actions</b> (Pages 295 - 296)	6.40 pm
11	<b>Correspondence</b> (Pages 297 - 298)	
12	<b>Work Programme Update</b> (Pages 299 - 300)	
13	<b>Urgent Items (if any)</b>	
14	<b>Terms of Reference - Waste Management Post Trial Review</b> (Pages 301 - 304)	6.45 pm
15	<b>Waste Management - Confidential Update</b> (Pages 305 - 310)	7.10 pm
16	<b>Date of next meeting</b>	7.25 pm

The next meeting is scheduled for 26 March 2024

**D Marles**

**Interim Monitoring Officer**

Date: Wednesday, 17 January 2024

Contact: Graham Porter, 02920 873401, g.porter@cardiff.gov.uk

## **WEBCASTING**

**This meeting will be filmed for live and/or subsequent broadcast on the Council's website. The whole of the meeting will be filmed, except where there are confidential or exempt items, and the footage will be on the website for 6 months. A copy of it will also be retained in accordance with the Council's data retention policy.**

**Members of the press and public may also film or record this meeting.**

**If you make a representation to the meeting you will be deemed to have consented to being filmed. By entering the body of the Chamber or meeting room you are also consenting to being filmed and to the possible use of those images and sound recordings for webcasting, public information, press coverage and/or training purposes.**

**If you have any queries regarding webcasting of meetings, please contact Democratic Services on 02920 872020 or email [Democratic Services](#)**

This page is intentionally left blank



GOVERNANCE AND AUDIT COMMITTEE

28 NOVEMBER 2023

Present: Chris Burns (Deputy Chairperson in the Chair)  
Gavin McArthur (Chairperson), David Price, Dr. Janet Wademan

Councillors Carr, Lewis, Palmer and Williams

1 : APOLOGIES FOR ABSENCE

Apologies were received from Councillors Goodway and Moultrie

2 : DECLARATIONS OF INTEREST

The following declarations of interest were made:

Cllr Williams	Item 4	Prejudicial	Contract with Council on private rental leasing scheme
Cllr Williams	Item 5	Personal	Family member works for Council
Cllr Palmer	Item 5	Personal	Family member works for Council

3 : MINUTES

The minutes of the meeting held on 24 October 2023 were approved by the Committee as a correct record and were signed by the Chairperson subject to the following amendments:

Item 26 - Amend date of minutes of previous meeting approved from 11 July 2022 to 11 July 2023

Page 8 – amend:

Members were re-assured that actions and mitigations had been put in place and asked if the Authority considered that there was an acceptable level of fraud cases in Cardiff. Officers responded that it was difficult to know what a good level of fraud cases was but it was something the Authority should be asking itself and reflecting on.

To read:

Members were re-assured that actions and mitigations had been put in place and asked officers to reflect on levels of fraud in Cardiff.

4 : UPDATE ON DIRECTORATE CONTROL ENVIRONMENT FOR PEOPLE & COMMUNITIES

*Councillor Williams declared a prejudicial interest in this item as he has a contract with the authority under the Private Rental Leasing Scheme.*

The Committee received a report providing an update on the control environment within the People and Communities directorate. The Chairperson welcomed Sarah McGill, Corporate Director – People and Communities to the meeting.

The report provided an overview of the directorate and set out the key service demands the directorate was facing. The report focussed on areas of the directorate not overseen by the Director of Adults, Housing and Communities or the Director of Children's Services who had both previously attended the Governance and Audit Committee to provide assurance on their areas of responsibility.

The report provided an overview of the directorate services and its governance arrangements. Members were advised that there are strong performance management arrangements in place including quarterly performance reporting covering key indicators (KPIs), corporate plan and directorate delivery plan objectives. Performance is reviewed regularly internally and performance is also monitored quarterly at various Scrutiny Committees. Further monitoring is provided by SMT and directorate assurance meetings. Individual performance is monitored through Personal Reviews and the directorate has a robust approach to ensuring that Personal Reviews are undertaken.

The report also provided a summary of the directorate approach to governance arrangements, performance management, internal audit engagement, risk management and external assurance.

Following a presentations from the Corporate Director, the Chairperson opened the debate on this item. Those discussions are summarised as follows:

- A Member welcomed the mapping of the partnerships between the authority and other bodies set out in the report. Officers were asked to expand on the next steps in that process – in particular where processes and relationships can be improved. The Corporate Director stated it has been a valuable exercise in terms of understanding the visibility of the partnership working arrangements. The task has helped officers to understand the significant number of issues that each organisation is seeking to resolve which are complex and can only be resolved in working together. There was considerable duplication – for example, the Regional Partnership Board, the Public Service Board and the Regional Safeguarding Board have identified issues covering the same areas. Though it is possible to set up Task and Finish Groups within those partnerships – it was important to map the accountabilities, responsibilities and where those activities are being undertaken, thus allowing for intelligence to be shared and a reduction in duplication. The Corporate Director considered that it was important for each body to retain its own decision-making responsibilities, but the alignment of those activities would allow a more co-ordinated approach to shared problems.
- Members referred to the risk matrix presented in the report. A Member questioned whether there was any general guidance for directorate risk registers and risk assessment. The Audit Manager stated that the Risk Management Strategy and Policy sets out guidance for measurement, reporting and response to risks across the authority. The approach is standard to support consistent

application at all levels.

- A Member requested the Corporate Director to comment on the challenges faced and the solutions implemented in terms of the control environment within the Directorate given that there is such a broad spectrum of services within the Directorate. The Corporate Director advised that there are two Directors within the Directorate for Children Services and Adult Services respectively. Those Directors fulfil their entire remit including the control environment. There is a significant level of assurance in respect of each of those parts of the wider Directorate. The Directorate Senior Management Team meets each fortnight to discuss issues and where challenges are identified a joint approach is taken to address them. The report sets out a number of significant challenges for the Directorate, including the increasing demand for services, that will need to be addressed quickly. The Corporate Director considered that not only are the good governance arrangements in place but the SMT is able to deploy a rapid response to emerging issues.
- A Member questioned how the 'knowledge' invested within the Directorate was managed and utilised in order to gain sustainability and create resilience for the future. The Corporate Directorate stated that sustainability and the development of the managers of the future was a key consideration for the Directorate. The Directorate is proud of the investment it makes in its staff and it is keen to ensure that the next generation of managers are developed 'in-house', in addition to attracting talent from outside the organisation. It was accepted that there are challenges in terms of recruitment for some professions within the Directorate and therefore there has been a significant focus on development. Furthermore, the governance arrangements in place allow for people from different disciplines to work together on problem-solving and understand the challenges faced in different service areas.
- A Member stated that the newly appointed Welsh Language Commissioner was adopting a different approach at aspects of delivery against Welsh Language Standards, particularly in areas where IT technology has developed. The Member asked what the Directorate was doing specifically to ensure that the organisation is compliant with Welsh Language Standards. The Corporate Director stated that the Head of Bilingual Cardiff regularly attends SMT and provides a regular reports in terms of compliance with the standards. The Directorate has a good relationship with the Commissioner and there is a good degree of understanding around the complexities of hosting certain data sets online. The Corporate Director considered that there has been a significant and sustained attempt to ensure that all services across the Council are meeting the requirements of the Welsh Language Standards.
- The Audit Manager confirmed that Welsh Language Standards compliance is audited and is also embedded into thematic audits. The opinion from the audit of Bilingual Cardiff approximately two years ago was not adverse and it was considered that the organisation addresses these issues sufficiently.

RESOLVED – That the report be noted.

5 : FINANCIAL UPDATE INCLUDING RESILIENCE ISSUES

*Councillor Palmer and Councillor Williams declared personal interests in this item under the Members Code of Conduct a family members are employed by the authority.*

The Corporate Director Resources and Section 151 Officer, Chris Lee, presented a financial update on resilience issues and the financial challenges facing the authority, including the Month 6 position and preparation for the 2024/25 budget.

- A Member asked whether, in terms of the revenue settlement figure, a number of potential scenarios are being modelled. The Corporate Director Resources confirmed that a range of scenarios are being modelled and officers have been in contact with the Welsh Government throughout. Notification of an indicative settlement at an average of 3.1% for 2024/25 for all local authorities was provided at the end of the last financial year. Cardiff would anticipate being higher than the 3.1% average.
- A Member noted the significant draw down of reserves built into the budget position. The Corporate Director Resources was asked whether modelling has been undertaken to understand how long this contribution would be sustainable given that reserves are finite. The Corporate Director Resources stated that the use of reserves is modelled into the Medium Term Financial Plan. The use of reserves during the current year are offsetting the current position and those reserves were earmarked for key areas such as adult social care, childrens services and recycling. The Corporate Director Resources considered that there needs to be a clear distinction between the base budget and the use of reserves. When reserves are used to fill a budget gap then that expenditure needs to be found in subsequent years. The use of reserves, critically, is not sustainable and would not be supported in the longer term.

RESOLVED – That the report be noted.

6 : COUNTER-FRAUD AND CORRUPTION STRATEGY AND OPERATIONAL POLICIES - UPDATE

The Committee received a report presented by the Audit Manager, Chris Pyke, providing Members with an opportunity to consider incremental updates that have been made to the Counter Fraud, Bribery and Corruption Strategy and a suite of counter-fraud operational documents. The updates had draft status and were due to be considered by Cabinet with a request for approval.

Members were advised that the Council has a responsibility to protect the public purse through proper administration and control of the public funds and assets. Fraud costs the public sector an estimated £50.2 billion annually, and of this total, £8.8 billion relates to local government. A Counter-Fraud and Corruption Strategy was introduced and approved by Cabinet in July 2019 to co-ordinate the counter-fraud policy framework and outline the strategic approach to tackling fraud across the organisation.

The Strategy incorporates best practice guidance and intelligence from the Chartered Institute of Public Finance and Accountancy (CIPFA) and is also based on best practice information and intelligence on the nature and management of fraud risks gained through lead counter-fraud officers participating in ongoing networking such as Core Cities UK, Welsh Chief Auditor and Welsh Investigator Groups.

The updates were discussed with the Council's Trade Unions in November 2023, and all documents have been supported by Single Impact Assessments with the engagement of the Council's Equalities Team and Bilingual Cardiff. Any commentary and guidance received through these processes to date is taken into account in the draft strategy.

The draft revised Strategy (Appendix A) has been updated to incorporate the incremental updates to best practice models, information and guidance as referred to above. The principal updates from the draft updates to the Strategy are:

- Enhanced Oversight
- Assurance Reviews
- Communication
- Training - Refreshed mandatory fraud awareness training for 2024/25 to support all staff.

The Counter-Fraud, Bribery and Corruption Strategy template for schools has also been updated and arrangements will be made to engage with school Headteachers and Chairs of Governors to outline the updates, provide relevant guidance and to commend the adoption of the Strategy by respective Governing Bodies.

In addition to updating the Counter-Fraud, Bribery and Corruption Strategy, the following operational documents have been subject to review and incremental update in line with best practices and are provided for Governance and Audit Committee consideration and comment:

- Counter-Fraud Bribery and Corruption Policy
- Fraud Response Plan
- Sanction Procedure
- Publicity Procedure

RESOLVED - That the Committee notes the draft updates to the Counter-Fraud, Bribery and Corruption Strategy and the operational counter-fraud documents.

7 : AUDIT AND INVESTIGATION TEAM - PROGRESS UPDATE

The Audit Manager presented the quarterly progress report providing the Committee with an update on the work and performance of the Internal Audit and Investigation Teams. The report covered the period from 1 July - 30 September 2023.

The Audit Manager was asked to comment on the spike in investigations in the Housing service area. The Audit Manager advised that the increase was a result of the release of National Fraud Initiative data matching information during the period.

A Member asked whether more clarity was required in terms of the officers declarations of interests and secondary employment, particularly around the circumstance when officer would be required to declare an interest. The Audit Manager stated that it was important for officers to understand their responsibilities and record interests correctly. Declarations of Interest and declarations of gifts and hospitality have formed part of Fraud Awareness Week and work is ongoing to digitalise the declaration process .

A Member asked the Audit Manager to comment on rationale for management's request for the additional resource being allocated toward in the area of financial management of the Council and Schools Non-Domestic Estate. The Audit Manager stated that there are no known risks or exposures, but the request follows consideration with relevant senior officers and audit.

RESOLVED – That

- (1) the report be noted
  
- (2) the proposed in-year amendment, to add an assurance audit engagement of 'building repairs and maintenance' to the Audit Plan be approved.

## 8 : CARDIFF COUNCIL - DETAILED AUDIT PLAN 2023

The Chairperson welcomed Sara-Jane Byrne and Julie Rees from Audit Wales to the meeting. Wales Audit presented the Detailed Audit Plan 2023. The plan set out the work programme for the year in three main areas – the audited Statement of Accounts, the review of value for money arrangements and compliance with the sustainable development principle. The Plan also set out the materiality that will be adopted for the core and group audits; identified areas or risk and focus; the timetable of works; and an analysis of the audit fee.

Members were asked to note the key risks and key areas of focus identified in the Plan. Further, Members were asked to note the increase in the fee relating to introduction of the new ISO315 standard. The key changes from ISO315 were set out in an appendix to the report. Julie Rees provided a summary of the changes.

Sara-Jane Byrne provided an overview of the performance audit programme including two thematic reviews on financial sustainability and commissioning and contract management. A local review on the Highways and Transportation will also be undertaken.

A Member referred to previous comments made regarding the Audit Plan report and, in particular, requests made for a breakdown of the fees and details of how Audit Wales officers will be deployed across the audits. The Member also requested a breakdown of the additional costs referred to in respect of the increase in fees in respect of undertakings for the new ISO315 standard.

The Chairperson requested that the Member provide details in writing in respect of the format for the breakdown of the fees requested. Members supported the request for the breakdown of fees and considered that this would provide the Committee with some assurance in terms of value for money. The Corporate Director Resources advised that there is a consultation process in place in terms of the fees.

Audit Wales gave an undertaking to provide a breakdown of the fees, as requested, and also provide some additional information in terms of how fees are calculated, benchmarking data and details of the consultation process.

Responding to a question from the Committee, Audit Wales confirmed that the financial accounts audit is underway and scheduled for completion in January 2024. Completion of the audit is later than in previous years as a result of internal resource pressures.

RESOLVED – That the report be noted.

## 9 : CORPORATE RISK MANAGEMENT 2023/24 (MID-YEAR)

The Committee received a report presented by the Head of Finance, Ian Allwood, on the risk management position at quarter two 2023/24 and highlighting changes from the previous report.

Members were asked to note that, as requested, an update was provided on the position of RAAC and associated risks. Also, as part of the risk escalation process, consideration was given to the Directorate risk in respect of ensuring an effective response to the increasing rise in homelessness. It was proposed that as from Q3 that this risk will be added to the Corporate Risk Register in order to ensure corporate oversight on this potential risk.

A Core Cities risk management working group has recently been set up, and the risk management team are participating in this group. The first piece of work to be undertaken will be a comparison of each City's Corporate Risks. This will be presented to a future meeting.

A Member noted that external funding was secured to fund a new post relating to the Climate Change and Carbon reduction risk. The Member asked whether there was scope to secure additional external funding from other sources. The Head of Finance agreed to provide Members with feedback regarding this before the next meeting.

A Member commented that a number of the corporate risks identified in the risk register generally move slowly towards their risk target and are often in a steady state. Officers were asked to consider the profile of change on the risk register over the medium to long term as a means of challenging management in terms of moving

those risks forward. The Head of Finance stated that the risk register is presented to SMT quarterly and the risks that are in a steady state are highlighted. The Head of Finance accepted the point and agreed to consider the matter further, particularly whether the risks should be compartmentalised in terms of those SMT are seeking to move forward and those that require the steady state to be maintained.

The Head of Finance also advised that discussions were taking place with colleagues in the Planning, Transport and Environment Directorate with a view to combining their Climate Change Risks into one sharper, more targeted, narrative.

RESOLVED – That the report be noted.

#### 10 : TREASURY MANAGEMENT HALF YEAR REPORT

The Committee received a report presented by the OM Accountancy Manager – Capital, Anil Hirani, on the Council's Treasury Management Activities since 1 April 2023 and the position as at 30 September 2023.

RESOLVED – That the report be noted.

#### 11 : OUTSTANDING ACTIONS

RESOLVED – That the report be noted.

#### 12 : CORRESPONDENCE

RESOLVED – That the report be noted.

#### 13 : WORK PROGRAMME UPDATE

RESOLVED – That the report be noted.

#### 14 : URGENT ITEMS (IF ANY)

No urgent items.

#### 15 : WASTE MANAGEMENT - POST TRIAL UPDATE

The Committee received a confidential briefing providing details relating to a large-scale investigation in the Waste Management Service following the arrest of eight individuals and a subsequent criminal investigation.

RESOLVED – That the report be noted.

#### 16 : DATE OF NEXT MEETING

The next meeting was scheduled for 23 January 2024.



The meeting terminated at 4.13 pm

This page is intentionally left blank

## **GOVERNANCE & AUDIT COMMITTEE: 23 JANUARY 2024**

---

### **PLANNING, TRANSPORT AND ENVIRONMENT CONTROL ENVIRONMENT UPDATE**

### **REPORT OF THE DIRECTOR OF PLANNING, TRANSPORT AND ENVIRONMENT**

**AGENDA ITEM: 4**

---

#### **Reason for this Report**

1. This report has been produced in response to the Governance and Audit Committee's request for an update on the Planning, Transport and Environment control environment.
2. The Governance Audit Committee has requested this update in respect of its role to:
  - Monitor progress in addressing risk-related issues reported to the committee.
  - Consider reports on the effectiveness of internal controls and monitor the implementation of agreed actions.
  - Consider the Council's framework of assurance and ensure that it adequately addresses the risk and priorities of the Council.
  - Consider the Council's arrangements to secure value for money and review assurances and assessments on the effectiveness of these arrangements.
  - Review the assessment of fraud risks and potential harm to the council from fraud and corruption.
  - Review the governance and assurance arrangements for significant partnerships or Collaborations.
  - Review and assess the authority's ability to handle complaints effectively and make any associated reports and recommendations.

## Background

3. The Planning, Transport & Environment Directorate (PTE) covers a wide and complex range of functions and services. The structure of the directorate consists of circa 454 FTE posts, the management structure and an outline of these functions can be seen below:

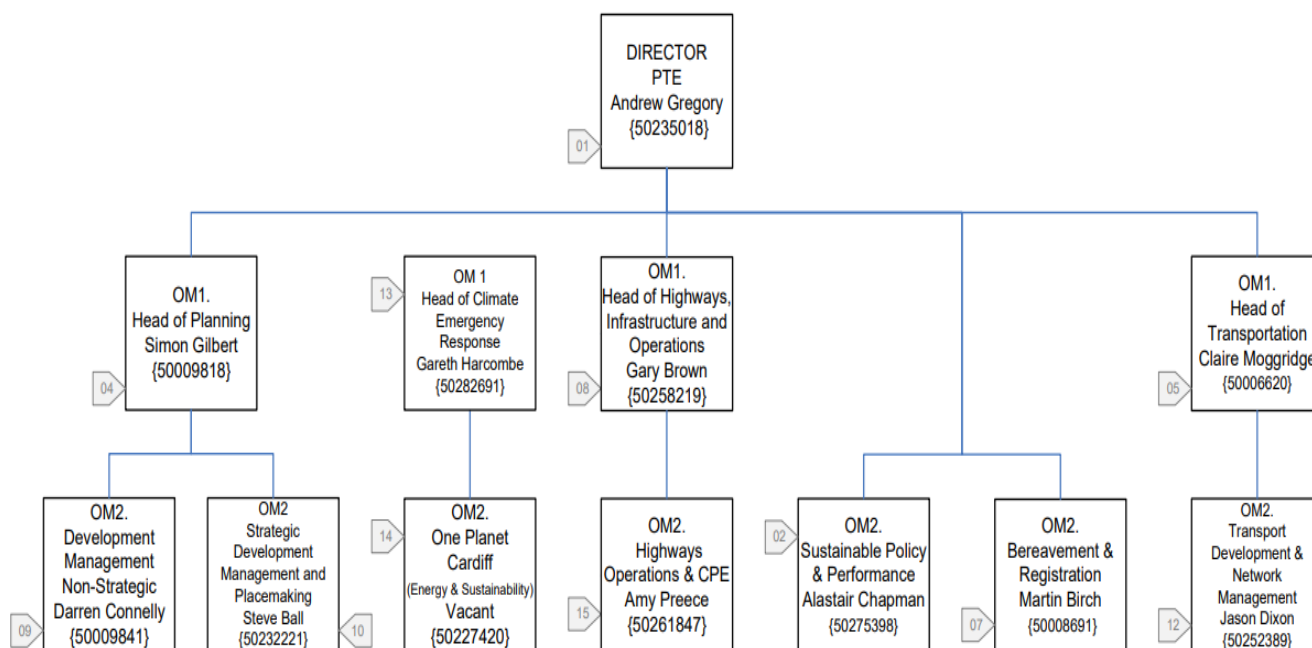

4. The Directorate has an overall annual budget of circa £9.3million (revenue) and £52.8million (capital). The Capital Budget varies from year to year, depending on the project programme and amount of external funding secured.

## Teams and Functions

Operational Team	Key Functions	No of Staff
Planning	Local Development Plan, planning applications, sustainable development, associated community infrastructure and good urban design through placemaking, enhancing the built environment	56
Transportation	Regional and City Transport Planning and Policy, City Centre transport improvements, active travel planning	88
Highways	Highway and winter maintenance, asset management, coastal defence, flood strategy, drainage, telematics, civil parking enforcement, street lighting	200
Bereavement, Registration & Dogs Home	Burial, Cremation and Exhumation of the dead and provision of memorial options. Registration of Births, Deaths, Marriages, and provision of ceremonies. Provision of dogs home for the safe holding and rehoming of dogs coming into the Councils care	87
Energy & Sustainability	One Planet Cardiff Strategy; carbon neutrality and climate emergency, food strategy, renewable energy, retrofitting support	6
Business Support	Support for performance management, governance, standards & compliance, finance, budgets, correspondence, workforce planning support (sickness, PDRs, training, recruitment), bespoke senior management support. SLA support to other services such as Recycling & Neighbourhood Services.	27

## Service Demands

5. To support the Council's Stronger, Fairer, Greener Strategy and Corporate Plan our Directorate Delivery Plan sets out key commitments to make Cardiff a greener city which, through the One Planet Cardiff programme, takes a lead on responding to the climate emergency; which celebrates and nurtures biodiversity, with high-quality open spaces within easy reach for rest and play; and which is connected by convenient, accessible, safe sustainable transport options.
6. In response to the Climate Emergency, the Council and directorate has set out the One Planet Cardiff Strategy which proposes a wide range of ambitious actions across energy, housing, transport, food, and water that form the basis of a delivery plan to achieve carbon neutrality and mitigate against the impact of rising sea levels and more frequent extreme weather events. It aims to do this in a way that supports new green economies and greater social wellbeing in the city.
7. Transforming how people move about the city remains central to decarbonising the city, requiring a major programme of improvement to the public transport and active travel network. As road traffic is one of the city's biggest contributing factors to air pollution, influencing travel behaviour by accelerating a shift towards sustainable and active travel will also lead to improvements in air quality. More broadly, our city's communities – old and new - must be well-planned and well-connected, with infrastructure and public services that are fit for the future.
8. Similarly, there is a need to further enhance and modernise the Bereavement & Registration Services and as such a 10-year strategy is in place that sets out a road map for the continued improvement and development of these essential front-line services over the next 10 years.
9. Cardiff Dogs Home is a statutory service which is undergoing a number of changes with help from the charitable friends group, The Rescue Hotel. The service is also looking to commercialise its activities where possible and move to a more sustainable financial position.
10. In supporting these aims, through the Corporate Plan and Directorate Delivery Plan, the directorate predominantly underpins Well-being Objective 6: **One Planet Cardiff**, however, we also support Well-being Objective 4: **Safe, confident and empowered communities** and Well-being Objective 5: **A capital city that works for Wales**, the following are key priorities that support these Well-being Objectives that we are delivering on:

## Directorate Priorities

<u>Directorate Priorities</u>	<u>Supporting Corporate Steps</u>
<b>Well-being Objective 6 - One Planet Cardiff</b>	
<b>Decarbonising the city and leading a green recovery</b>	Report on the progress of delivering the One Planet Cardiff strategy
	Take bold leadership on climate change
	Deliver the Design and Build contract for Phase 1 of the Cardiff Heat Network
	Take a strategic approach to energy
	Increase energy efficiency and reduce carbon emissions through a Housing Energy Efficiency Retrofit programme
	Set out an electric vehicle infrastructure road map
	Promote healthy, local and low-carbon food

	Lead the debate on the potential for renewable energy in the Severn Estuary
<b>Transforming Cardiff's public transport and active travel systems</b>	Work in partnership with Welsh Government, Transport for Wales and the Burns Transport Commission Delivery Unit to design and deliver a Cardiff and Regional (Metro) Tram network
	Continue to progress transport and clean air improvements in the city centre
	Ensure good air quality
	Support public transport aspirations in the Transport White Paper
	Programme the delivery of the bridge crossing scheme at Llanrumney
	Continue to invest in a segregated cycle network across the city
	Progress a programme of work to fulfil the Council's statutory duty under the Active Travel Act
	Nurture a strong active travel culture in every Cardiff school
	Prepare an Intelligent Transport System Strategy
	Make streets safer and greener
	Consider and review road user charging options
<b>Putting sustainability and wellbeing at the heart of the city's growth</b>	Conduct a full review of the Local Development Plan (LDP)
	Create better places through the delivery of new, high-quality, well-designed, sustainable, and well-connected communities
	Deliver the Council's Green Infrastructure Plan
<b>Enhancing Cardiff's flood defences</b>	Develop a draft sustainable water, flood, and drainage strategy for Cardiff
	Complete coastal defence improvements in Cardiff East
	Deliver phase 1 of the new Canal Quarter scheme
<b>Building resilience into our highway network</b>	Continue to deliver the programme to replace all 24,000 residential lighting to low-energy LED lighting
	Continue to deliver an extensive programme of localised improvements to our roads and footways
	Target the deployment of civil parking enforcement activity through the effective utilisation of data and technology
<b><u>Well-being Objective 4 - Safe, confident, and empowered communities</u></b>	
<b>Building new Council homes and investing in community facilities</b>	Further enhance Bereavement & Registration Services through modernising service delivery

<b>Well-being Objective 5 - A capital city that works for Wales</b>
Additionally, the directorate supports several shared Corporate Steps with Economic Development including; Adopting the new Smart City roadmap and supporting the completion of Cardiff Parkway as part of our Industrial Strategy for the East of the city.
<b>Corporate Plan / Directorate Plan Measures / KPIs</b>
A number of Measures / KPIs are also in place to help gauge the extent of delivery of Corporate Steps, including for example; Air quality concentrations, Schools supported to introduce Active Travel Plans, Major & Householder planning applications agreed and Roads that are in overall poor condition.

## Directors Oversight

11. The Director has oversight and involvement across functions and areas, some examples are outlined in the table below, during the year two key self-assessments are undertaken by the Director to outline key progress, challenges, and priorities, these are subject to challenge sessions with the Chief Executive.

<b>Performance / Governance / Compliance Area</b>	<b>Purpose</b>	<b>Who's involved / where reported</b>	<b>Director's Oversight &amp; Control</b>
Corporate Plan / Directorate Delivery Plan	Council & Directorate Priorities Remit, Current & Future Planning	Director, OMs, Performance Leads, Team Leaders (Leader/Members, SMT, DMT & Bespoke Planning Mtgs)	Leads on development, liaises with Members, agrees priorities, changes & sign off for publication, presents to Scrutiny, staff awareness
Quarterly Performance Reviews	Gauge extent of delivery of Corporate Steps & Measures	Director, OMs, Performance Leads Team Leaders (SMT, DMT & Bespoke Mtgs with Performance Leads)	Reviews and authorises narrative and ratings, agrees on content prior to submission
Risk Management / Registers	Manage & Control impacts	Director, OMs, Risk Champion (SMT, DMT, Bespoke Mtgs with Risk Owners)	Agrees on risk inclusions, moderates and agrees on controls, mitigations and escalations to SMT and reports to Audit Committee
Self-Assessment / Director Challenge Sessions	Gauge extent of progress, challenges & priorities	Director, OMs, Performance Leads (SMT, DMT, Bespoke Mtgs with Performance Leads, CEx Challenge Sessions)	Involvement and signs off inclusions in presentation slides, presents to CEx Challenge Session
Internal & External Audits	Compliance & conformity of operations	Director, OMs, Performance Leads, Team Leaders, Audit Relationship Manager (SMT, DMT, Audit Relationship Mtgs, Audit rollout)	Meets with internal & external audit to agree on principles / approach, agrees on recommendations and management response, reports to Governance and Audit Committee

Senior Management Assurance Statements	Governance & internal control	Director, OMs, SMAS Champion (SMT, DMT, Bespoke Audit Champion Mtgs)	Involvement in SMAS evidence gathering, moderating and agreeing on statement ratings, agree action plan for improvement, reports to Audit Committee
Cabinet Reporting	Decision Making	Director, OMs, Team Leaders, Management Officer (SMT, DMT, Members, Cabinet Office, Supporting Services i.e. Legal, Scrutiny, Cabinet,	Agrees on schedule of reporting, agrees on final report, presents to Cabinet as required
Budgets	Financial Management	Director, OMs, Finance Team Leader (SMT, DMT, Financial Services Mtgs, Bespoke Mtgs with Finance Leads)	Leads on Directorate budget management, ensuring the Directorate remains within cash limits and utilises resources in the most effective, efficient, and economic way. Leads on the delivery of saving proposals, and is responsible for identifying mitigation if proposals are delayed/ changed etc.
Workforce Plan related – Sickness, PDRs, Training	Resource Management, Objectives Review, Learning & Development	Director, OMs, Workforce Champion (SMT, DMT, Team Leader Mtgs, HR Mtgs)	Leads on reviews of sickness, PDR outturn and mandatory training, agrees on improvement actions
Correspondence / Complaints	Customer Insight	Director, OMs, Team Leader, Correspondence Team (SMT, DMT, Bespoke Corporate Complaints Team, Member Services and Cabinet Office Mtgs)	Reviews Correspondence & Complaint outturn, manages issue relating to under-target areas, reports to Audit Committee
Programmes & Projects	Management of Key Work	Director, OMS, Project Leads & Team (Leader, SMT, DMT, Bespoke Programme / Project Mtgs)	Chairs appropriate programmes, agrees on governance arrangement, reports to Leader, Members & Chief Executive, pushes forward key decisions, issues and mitigations
Health & Safety / Service Area Joint Committee (SAJC)	Prevent accidents and injury, Trade Union Consultation	Director, OMs, Health & Safety Champion (H&S Committee, SAJC, DMT)	Chairs H&S Committee and SAJC, agrees agenda items and actions

## Issues

### (a) Risk Management

12. Risks relevant to the directorate are captured and detailed in two main Registers: Corporate (strategic risks) and Directorate (essentially delivery plan and operational risks). In conjunction with these and feeding into the risk reporting process are Team ('day to day' work delivery risks)



and Programme (project risks) Registers. Team leaders meet with Operational Managers on a weekly / fortnightly basis to discuss any Team specific issues. From this process new potential risks are identified and cascaded upwards to the Directorate Management Team (DMT) weekly management meeting, where risk is a standing agenda item, for intervention / escalation decisions by the Director, as necessary.

13. Similarly, weekly Programme Management meetings are held with responsible officers (Project Leads, Operational Manager's, Director, and Risk Champion) where key project delivery risks are raised, discussed, monitored, and reported to the Director, for intervention and escalation decisions, as necessary.
14. On a Corporate level, our two main Registers (Corporate & Directorate) are monitored formally on a quarterly basis, within an embedded and well-established process. Meetings are scheduled and held with responsible officers (Operational Managers, Team Leaders, and Risk Champion) to review and update the risk position on all risks, including any newly identified risks, then both Registers are reviewed and approved by the Director prior to formal reporting, to ensure that:
  - Risks are relevant (including adoption of new risks)
  - Status / risk rating is appropriate
  - Controls are in place and supporting mitigations are working
  - Interventions are provided by the director to ensure risks are robust
  - Decisions made to help manage the process
  - Updates on the latest position are recorded accordingly
  - Target dates are provided for proposed management actions
  - Key performance indicators / measures are in place to monitor / track risk reduction, which include:
    - Statistics / Data
    - Milestones
    - Reports
    - Experience / Feedback
    - Results
    - Documented issues from management meetings to inform the risks
15. Escalation of high-level risks within the directorate is part of the Council's Senior Management Team (SMT) review process, whereby they can be considered for inclusion on the Corporate Risk Register if required. This includes any new significant risks identified outside of the quarterly reporting cycle. There have been no risks escalated to SMT in the last year that are not sitting on the Corporate Risk Register.
16. Reporting is as of Q2 position. The Q3 position is in the process of being finalised, currently there are no proposed changes to the reporting or governance structures.

### **High Level Corporate Risks (see Appendix A for summary)**

17. The directorate has a number of high-level corporate risks sitting on the Corporate Risk Register (CRR) which have been identified, assessed, and escalated through the risk management process via DMT, then SMT, as described above. The Climate Change risk was originally one generic risk, however, due to the diverse and specific nature of the elements that make up that risk, it was agreed in conjunction with the Corporate Risk team from 2020/21 that the specific elements would be reported on in their own right, in order to capture / monitor the specific risk / consequences / ratings / controls / planned actions etc, with an overarching Climate Change

summary on the CRR. However, as the individual risks have been mitigated and reduced over time, they have reached a point where they are all aligned in terms of risk rating, therefore the summary has been removed as of Q2 2023/24. There is a proposed review of the Climate Change risks being undertaken (targeting Q4 2023/24 or Q1 2024/25. We are aware that Members see the CRR on a regular basis, therefore the attached Appendix B is an outline summary only.

### **High Level Directorate Risks (see Appendix B for full detail)**

18. The Directorate Risk Register (DRR) is a strategic document and is directly aligned with the Directorate Delivery Plan and relevant Stronger, Fairer, Greener objectives, as well as capturing any other key risk perspectives, such as:

- Financial
- Legal & Regulatory
- Health & Safety
- Service Delivery
- Reputational

19. There are a number of identified directorate risks, of varying severity. As Members do not generally get to see the DRR, a full list of key red / amber risks *after mitigation* are included in Appendix B – the full detail of all directorate risks, including those that are green can be found in the Directorate Risk Register.

### **(b) Internal Audit Engagement and Response**

20. Audit reports are reviewed and owned by service areas and lead officers as appropriate. Co-ordination and monitoring are undertaken by the directorate's business support team with quarterly audit review meetings led by the Sustainability Policy & Performance OM. Notwithstanding the quarterly review meetings, outstanding matters are raised though DMT meetings. On a quarterly basis the directorate has meetings with the appointed relationship manager from audit which provides valuable assurance and forward preparation for up-and-coming audits. The recent Thematic Performance Management Audit found the directorate to be effective with no recommendations.

### **Internal Audit Assurance**

21. A summary of audit reports and outstanding recommendations in provided in the table below:

Audit	Report Status	Assurance Rating	Outstanding Actions	Completed Actions	Total Actions	Implementation Status	Directorate Update
2023/24 (to date)							
Planning	Draft	Effective, Opportunity for improvement	Management are considering the audit report and recommendations				N/A
Performance Management	Final	Effective	0	0	0	No recommendations raised	N/A
2022/23							
Cardiff Dogs Home	Final	Effective, Opportunity for improvement	1	17	18	1 open recommendation with a revised implementation date of 29.02.2024	Final action to cross check dogs home records against those held on the Academy Website due to be completed in February 2024.
Income and Debtors	Final	No directorate opinion – sampled as part of corporate audit	4	5	9	4 open recommendations with revised target date of 31-3-24	Ongoing discussions to resolve final elements in relation to event parking management.
2021/22							
Section 106 Agreements	Final	Insufficient, major improvement needed	0	4	4	Audit Closed	N/A
Pre-contract Assurance	Final	Insufficient, major improvement needed	0	2	2	Audit Closed	N/A
Concessionary Travel	Final	Effective, Opportunity for improvement	3	2	5	3 open recommendations with revised target 1-4-24	Remaining actions in final stages of completion
Contract Monitoring and Management - PTE (Passenger Transport)	Final	No directorate opinion – sampled as part of corporate audit	3	1	4	3 open recommendations with revised target 1-4-24	2 Actions currently seeking closure with the remainder in final stages
Income and Debtors - PTE	Final	Effective, Opportunity for improvement	2	2	4	2 open recommendations (with target dates of 31.03.2024 & 30.04.2024)	Remaining action in relation to CIS instructions awaiting installation of Idox system in Building Control. Online form system developed for Bereavement Services with follow up phone payments.

Audit	Report Status	Assurance Rating	Outstanding Actions	Completed Actions	Total Actions	Implementation Status	Directorate Update
Older – Longstanding Open Recommendations							
Bereavement Services	Final	Insufficient, major improvement needed	1	31	32	1 open recommendation, overdue with a revised target date of 30-4-24	Remaining action is in relation to establishing a contract for electrical and lighting services. Following discussion on service needs, feedback and options are awaited from procurement team.
Asset Management	Final	Insufficient, major improvement needed	1	5	6	1 open recommendation with a revised implementation date of 31.03.2024	Remaining actions relate to street lighting replacement with LED programme. This is due to be completed shortly with updates to the AMX asset management system to follow accordingly.

## **(c) The Wider Control Environment**

### **Senior Management Assurance Statement (SMAS)**

22. The Senior Management Assurance Statement is reviewed by the Director throughout the year, this review takes into consideration several requirements including; what evidence is available to support each Senior Management Assurance Statement, to identify an appropriate rating, and to consolidate the position for the directorate. To support this work Operational Managers also undertake individual reviews and these outcomes are analysed to portray the position across core Directorate Teams, this analysis is considered by the Director to provide oversight when considering the final ratings for the directorate and to identify any improvement actions.
23. Over recent years an Action Plan has been developed to help the directorate address and embed the subject matter within Assurance Statements, and a number of ratings have increased / improved as a consequence from “mixed application” to “strong application” due to targeted actions, for example; ensuring robust risk reviews are carried out with risk owners and Director, improving Quarterly Performance Reviews through manager awareness sessions on effective and robust Performance Reporting, use of easy access shared sharepoint review documents for ease of reporting, and managers attending SMAS and Future Generation Act awareness sessions.
24. Senior Management Assurance Statements are reviewed on a 6 monthly basis to provide oversight and are reported to the Council’s Senior Management Team. The latest review for Planning Transport & Environment shows in the main, particularly good assurance levels, with a rating of “strong application” across all the statements considered.
25. In terms of the 9 key categories / types of assurance the position is as follows:
  1. Risk – Strong Application
  2. Partnership Working – Strong Application
  3. Engaging Equalities - Strong Application
  4. Compliance - Strong Application
  5. Project Initiation – Strong Application
  6. Budget – Strong / Embedded Application
  7. Planning & Performance - Strong Application
  8. Control – Strong Application
  9. Counter-Fraud – Strong Application

## **(d) External Assurance**

26. During July 2023 an external assessment was undertaken on PTE’s Highway Maintenance Team by the British Standards Institute (BSI) and in particular focussed on a number of National Highway Sector Schemes (NHSS) which are integral to the effective delivery of maintenance works, these being NHSS 8 (electrical apparatus and street lighting), NHSS 10b (barrier repair on high-speed routes) and NHSS 12a/b (traffic management arrangements).

The assessment was undertaken over two days and covered the BS EN ISO 9001:2015 Quality Management System's key principles of Plan, Do, Check and Act. No non-conformities or observations were raised during the assessment, with the key outcome being that the Quality Management System accreditation was successfully retained.

## **Audit Wales**

27. As part of Audit Wales 'Assurance and Risk Assessment Review' (2022/23) it was recommended that the Council should '*determine the resource and cost implications of delivering its 'One Planet Cardiff' Net Zero Carbon 2030 strategy*'.
28. The One Planet Cardiff approach is not to rely solely on 'standalone' carbon reduction or climate resilience projects but to transition to a position where climate change considerations are integral within decision making. Indeed, a significant element of the strategy will rely on multiple small behavioural changes over time, which by their nature, are very difficult at financial costs with any degree of accuracy.
29. Whilst individual projects can be and are costed the strategy has a much broader influence through the delivery of council services. There are no straight forward or authoritative methodologies to assess this type of strategy. With new research, technology, business models and funding stream opportunities constantly evolving and far from fixed; our approach will inevitably need to be iterative, responding to progress and contextual change across the decade. For example, the Council has estimated the likely total cost of decarbonising all of its operational buildings but an exercise to estimate the costs of net zero procurement spend would be prohibitively complex. However, a Socially Sustainable Procurement Strategy is in place and clearly establishes our direction of travel and "asks" of suppliers in the longer term. The council monitors and reports on its Carbon and One Planet Strategy performance every year ([OPC action plan review ENG V4.pdf \(oneplanetcardiff.co.uk\)](#), [One Planet Cardiff - Annual Review 2022 - Cabinet Report \(v0.6\) rto 20221115 \(moderngov.co.uk\)](#))
30. To support the development of evaluative processes we are putting the following actions in place:
  - Working with the corporate policy team, over the next 18months review and ensure Climate Change is built into the Council's governance and decision-making frameworks.
  - Work to increase definition within carbon reporting and modelling so that progress in defined areas can be clearly examined. This will continue to evolve but the first step change by March 2024
  - Annual report on One Planet actions and develop a framework for financial reporting on activity for 2024/25)
  - Through procurement continue to build our understanding of carbon considerations in the procurement process and develop appropriate assessment tools to embed carbon reduction and climate resilience within projects.

## **(e) Major Project and Partnership Governance**

### **1. Transport**

31. Partnership working arrangements continue to be important for the delivery of the objectives included in the Stronger, Fairer, Greener Strategy, Corporate Plan, Transport White Paper, and One Planet Strategy. The Climate Emergency Programme Board continues to meet quarterly with public sector organisations to share plans and strategies and agree actions

working towards carbon reduction targets including implementation of initiatives of the travel charter such as reviewing vehicle fleets, energy and encouraging sustainable travel.

32. The partnership working arrangements established with Welsh Government, Transport for Wales, Burns Delivery Unit and Cardiff City Region have progressed to delivery of Cardiff Metro improvements such as Cardiff Central Station Enhancements, Crossrail and New Stations as described in the Transport White Paper. The work is at various stages of development or implementation and includes preparing business cases to support bids for funding, managing risks and programmes and monitoring progress managed with agendas, minutes, and action logs. The partnership working arrangements successfully achieved match funding between the UK Government and Welsh Government of £100m (£50m each) to deliver Phase 1 of Crossrail between Cardiff Central and Cardiff Bay.
33. Collaborative working arrangements are currently being put in place for the Road User Payment scheme with the Welsh Government and Transport for Wales to progress the Business Case development work based on WeITAG Guidance and the 5-case model. Governance arrangements have been agreed including a Member Board, Programme Board, Partnership Board, Steering Group, Coordination Officer Group, and arrangements for engagement with the South-East Wales Corporate Joint Committee. The governance arrangements are included in a Project Execution Plan including decision making and responsibilities. Key decisions, milestones and risks are reported from the coordination officer group with oversight of consultancy activities to the steering group and boards. Most decisions are made by the Senior Responsible Officer, Director of Planning, Transport and Environment through delegation by Cabinet in April 2024. The decision on any preferred option is reserved for Cabinet with the final option to be decided by Full Council.
34. The Regional working arrangements that were set up through the City Deal have facilitated the working relationships being established for the South-East Wales Corporate Joint Committee that is responsible for preparing the Regional Transport Plan.
35. Other partnership working arrangements are project based in less formal ways to encourage open engagement and facilitate flexible changes in scope and participation to meet the Equality Act and Wellbeing of Future Generations Act requirements. The governance and collaborative working arrangements are tailored to the scale and scope of each project. Ongoing regular meetings, engagement and correspondence is undertaken with key stakeholders and partners on specific transport related schemes and initiatives e.g. database of stakeholder consultees including Equalities Engagement Liaison Forum, disability representatives, Cycling Liaison Group, Emergency Services, Bus Operators, Public Health Wales, Natural Resources Wales, Regional Transport Groups, FOR Cardiff, Business, Developers, Universities, Cardiff Research Centre engagement with under-represented and community groups, Schools, Cardiff's Child Friendly City Programme, Cardiff Youth Council, Councillors, Charities and through social media / "Keeping Cardiff Moving" website) seeking to inform and obtain feedback and ideas according to the five ways of working (long-term, integration, involvement, collaboration and prevention) and promotion and adoption of best practice in relation to active travel, public transport, sustainability initiatives, regeneration, clean air and carbon reduction.

## **2. One Planet Cardiff**

36. The governance and oversight arrangements for the One Planet Cardiff strategy are conceptualised in the diagram below. Strategy implementation requires a network of activity with both internal and external partners. The core elements being a Cabinet Portfolio led steering group, Net Zero council group chaired by the Chief Executive and the Project

Delivery Group. The common factor in these arrangements is the participation and lead from the Director and OPC project lead.

37. In addition to, and feeding into, the above groups there are a number of project or task and finish teams. For example, Estates has a Carbon Reduction Board, which is attended by the OPC lead and focuses on climate emergency issues and projects in relation to energy efficiency and carbon reduction in the council estate. Similarly for the delivery of a One Planet business event this year a task and finish group was established to plan delivery and review the event. These types of groups report to the project delivery group, Net Zero Council and Steering Group ensuring engagement and oversight.
38. The director and officers also hold fortnightly update meetings with the Climate Emergency Portfolio holder. This is a more informal space where emerging ideas, projects, challenges, or requests can be discussed at an early stage.
39. Externally the directorate also supports the public sector Climate Emergency Board. The function of the board is to identify areas where public services can work jointly on climate emergency initiatives. The co-ordination and organisation is delivered by the directorate, this board reports to Public Services Board.

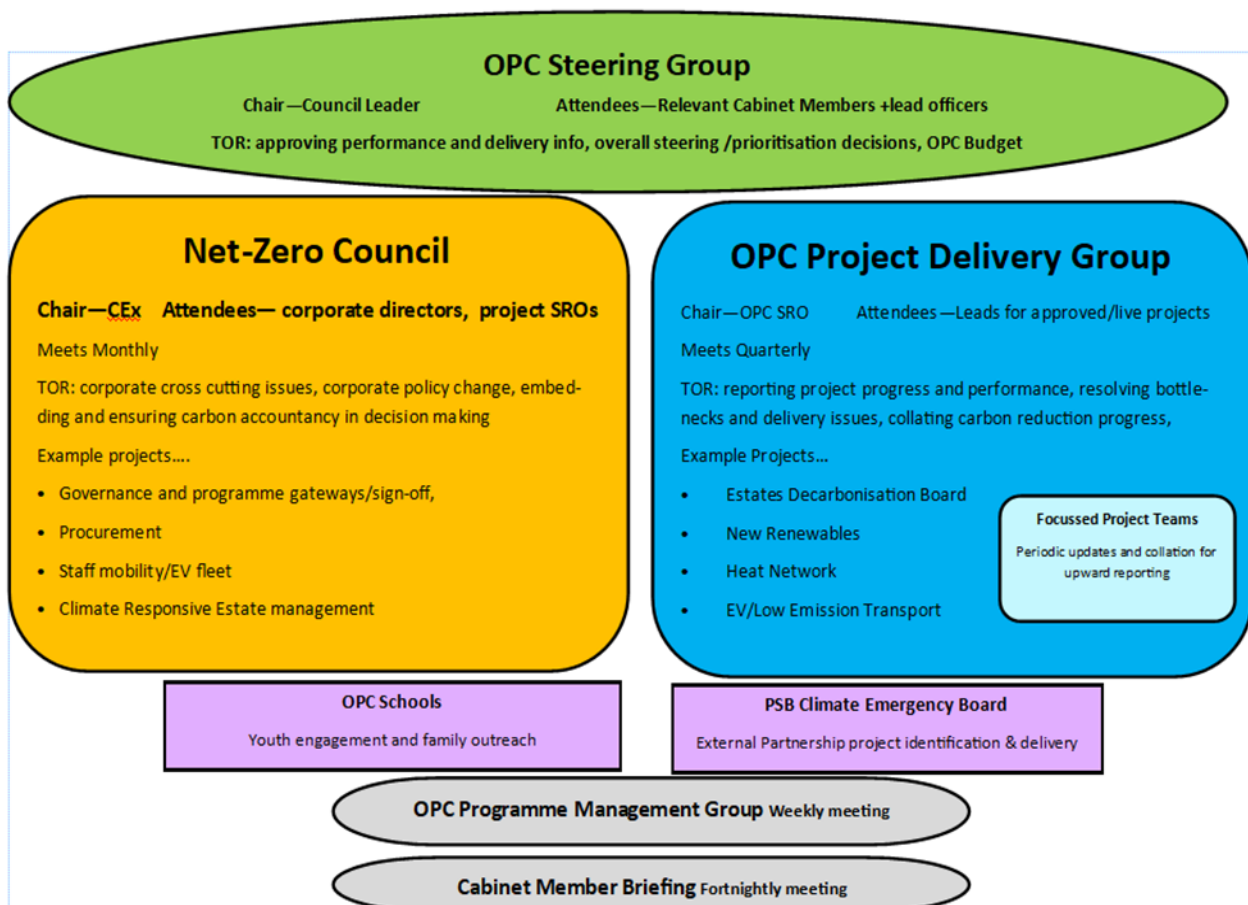

Diagram - One Planet Cardiff Governance structure.

40. The Directorate also holds a “special purpose vehicle” for the delivery of the Heat Network. Cardiff Heat Network Ltd is a company wholly owned by the Council and managed by a Board of Directors. Currently the directors are all Council employees appointed by the Council’s Chief Executive. The Board operates within strict terms of reference and delegated powers set out in the company’s Articles of Association. The director has been appointed as the



council's Shareholder's Representative and has delegated powers to authorise any actions or business plan amendments that fall outside of the Board of Directors' delegations. A regular meeting chaired by the Chief Executive is held to receive project updates and to discuss any significant matters arising or issues that interface with other council projects and priorities. Cardiff Heat Network Ltd is also subject to an independent annual financial audit and periodic performance audits all of which have been satisfactory to date.

<b><u>Programme / Key Work Area</u></b>	<b><u>Purpose</u></b>	<b><u>Membership</u></b>	<b><u>Frequenc y &amp; Plans</u></b>	<b><u>Priorities</u></b>	<b><u>Reporting Arrangements</u></b>
One Planet Cardiff Steering Group (see diagram)	To approve performance and delivery information, overall steering/ prioritisation of decisions as well as the One Planet Cardiff Budget.	Cllrs Wild (Chair), Thomas, Thorne, De'Ath, Merry, Weaver & Burke  Andrew Gregory Gareth Harcombe Alastair Chapman	Quarterly	Oversight of overall programme and delivery outcomes and prioritisation, and development of outward facing narrative on progress	Cabinet, with items escalated as necessary and advised by the Board. Formal delegation to apportion OPC "Small Projects" budget delegated to the Board via OPC Cabinet report
Net Zero Council	Corporate crosscutting issues including corporate policy, behavioural change and strategic resolution	Chief Exec (chair)  Directors  Project leads as necessary	Monthly	To champion OPC strategy across directorates at senior level. Discuss and resolve priorities	Cabinet and SMT, where appropriate
One Planet Cardiff Project Delivery Group (see diagram)	Directorates with project and programme interest in OPC	Andrew Gregory  Gareth Harcombe,  Alastair Chapman,  and project leads as necessary	Quarterly	Reporting project progress and performance, resolving bottlenecks and delivery issues, collating carbon reduction progress.	OPC Steering Group and/or Net Zero Council Group as necessary
Climate Emergency Board (see diagram)	To facilitate joined up public sector approaches to climate emergency response	Representatio n from public sector and universities operating within Cardiff e.g. NHs, Police, Fire, NRW etc	Every 2 months	Partnership working on climate emergency response projects and proposals	Public Services Board

### **3. Planning**

41. The Planning Service is actively engaged in a wide range of partnership and collaborative arrangements. In terms of planning policy, the Council is actively engaged in working collaboratively as we prepare a replacement Local Development Plan for Cardiff. This is a statutory duty on all Local Planning Authorities prescribed by Welsh Government including an agreed “Delivery Agreement” which was approved by full Council. We are currently considering the responses to the “Preferred Strategy” consultation undertaken over the summer of 2023 and preparing the draft policies and evidence base to form the “Deposit Plan” which will be the subject of further public consultation and engagement over the summer of 2024. Innovative consultation and engagement approaches have been employed in the preparation of the Replacement LDP, including the use of social media, on-line “virtual consultation rooms”, user-friendly material and bespoke consultation events hosted by external facilitators across the city. Each formal stage of the Local Development Plan is approved by the full Council and is subject to pre-decision Scrutiny as well as a bespoke joint Scrutiny Task and Finish at each consultative stage. Furthermore, the Plan is subject to an “Examination in Public” which is essentially a public Inquiry facilitated and hosted by the Council but led by an independent Planning Inspector on behalf of the Welsh Ministers.
42. In addition, senior planning officers attend the Planning Officers Society for Wales (POSW) meetings attended by all Heads of Planning across Wales, as well as regional collaboration through SEWSPG (South-East Wales Strategic Planning Group), and the OM Major Development has facilitated an all-Wales Development Mangers Group which reports directly to POSW also. These meetings have agreed terms of reference and support collaborative working across Planning Services in Wales and within the region. The Service also attends, and hosts Core Cities meetings attended by Chief Planners across all UK Core Cities. These meetings also have agreed terms of reference and input into wider core city governance arrangements. The directorate has a commitment to creating strategic partnerships across Council Service Areas, with key stakeholders in the development sector, as well as with other statutory bodies such as Local Health Boards, Universities and Welsh Government Departments.
43. The Head of Planning also chairs the Safety Advisory Group which looks at safety at sports grounds and venues and is attended by colleagues in Emergency Management and Legal Services, as well as senior representatives from the emergency services. These meetings are minuted and occur approximately every 2 months and are hosted virtually.

### **4. Flooding & Drainage**

#### Flood Risk Management (FRM)

44. The Flood and Coastal Risk Management Team continue to work collaboratively with several organisations and agents to reduce flood risk and address concerns from numerous sources - surface water, watercourses, coastal, main rivers, and drainage systems.
45. The partnership working arrangements with Welsh Government have progressed to deliver numerous schemes associated with the following grant opportunities:
- Flood and Coastal Risk management Capital Schemes
  - Flood and Coastal Risk Management Small scale works
  - Flood and coastal risk management revenue grant
  - Coastal Risk Management Programme
  - Coal tip Safety Grant

46. The majority of the funding, between 100 and 80%, is supplied by Welsh Government (WG), and requires an application and qualification process to be followed. Depending on the value of the funding, the qualification and governance requirements will differ. For example, the Coastal Defence Scheme went through a Welsh Government multi-application process that commenced at concept and went through an Outline Business Case (OBC) and to a Full Business Case (FBC) application and qualification process.
47. The Coastal Risk Management programme to approve commitment to detailed design (2018) and the FBC and Procurement strategy (2021), were taken through the Cabinet approval process by the Senior Responsible Officer, Director of Planning, Transport and Environment. The decision on any preferred option is reserved for Cabinet and as and when required, as has been the case with the Coastal project, also through Environmental Scrutiny review.
48. In addition, further qualification from third party stakeholders was required e.g. Marine Licence and Coastal Protection Act approval from NRW and Crown Estates land agreements. The risks of the Coastal Defence Scheme are captured in the Directorate and Corporate Risk Register and reported on quarterly.
49. Lesser schemes, such as Flood and Coastal Risk Management Small Scale Works are also subject to WG qualification and governance processes but not necessarily to the same extent. A Business Justification Case will need to be submitted but due to the schemes being less complex in nature and of a lesser value, the full FBC and additional qualification process may not be necessary. However, depending on the value of the spend, an Officer Decision Report may be required to ensure any decisions and commitments are captured appropriately.
50. In all cases, procurement rules are followed, and the approach taken aligned to the scheme being delivered.
51. The Flood and Coastal Risk Management Team also work with:
  - NRW and Welsh Water for the investigation and mitigation of pollution incidents / misconnections to watercourses.
  - Welsh Water on flood risk schemes that interact / effect their assets.
  - South-East Wales Coastal group regarding the Council's Shoreline Management Plan that includes organisations such as NRW / Environment Agency and other Local Authorities along the Severn Estuary.
  - The wider River Taff masterplan with NRW / Rhondda Cynon Taff / Vale of Glamorgan.
  - South-East Wales Flood Risk Group that includes all other Local Authorities in the area.
  - WG and The Coal Authority for the management of coal tips.
  - Academic institutions such as University of South Wales / Cardiff University and Bath University.

## **5. Highways**

52. The Highway Infrastructure and Operations Teams actively engage with the County Surveyors Society Wales (CSSW). This is a professional association of Local Authority officers who operate at both operational and strategic tiers of local government in Wales. They play a key role in planning and delivering local and national initiatives. The CSSW has members from each of the 22 Local Authorities across Wales and has strong links with the Welsh Government and Welsh Local Government Association. They work closely with the Association of Directors of Environment, Economy, Planning and Transport (ADEPT), the Society of Chief Officers of Transport in Scotland (SCOTS) and the Northern Ireland Road Service.

53. The CSSW has several management groups such as the Main Group which is made up of senior Local Authority officers and the Engineering Committee to which Cardiff's Highway Infrastructure and Operations teams have representation. Several groups have been established to review specific activities and functions which are supported by staff from the 22 Local Authorities, these groups report to the management committee, and they are vital in providing capacity to tackle common issues and in building skills and capability.
54. One of these groups is the CSS Asset Management & Performance Group, a notable example of an output from this group with the support of their term Consultants EXP, is the production of the 'All Wales' approach to the updated Highways Code of Practice. The group developed a new risk-based approach providing guidance for Local Authorities on establishing an effective network hierarchy, and inspection and repair regime. This guidance was used to produce Cardiff Council's Cabinet approved Highway Maintenance Policy document Part C:001 Highway Safety inspections, which has also been subject to an Audit review.
55. An annual programme of major highway improvements is delivered via competitive tender, delivery of these improvement works often requires both internal and external collaboration, liaison, and consultation. The Cabinet approved Highway Asset Management Plan (HAMP-3) describes how the Highway Infrastructure and Operations teams link through to the Council's Corporate Aspiration exploring the opportunity to focus on aligning the HAMP with the wider corporate priorities found in the Stronger, Fairer, Greener vision. In this regard the HAMP seeks to align and integrate to wider corporate strategies and will seek to:
- Align the strategy with – where possible - developing a low carbon response to Highway management and maintenance.
  - Maximise the integration of sustainable mode use on the Highway.
  - Regard the Highways within the wider context of creating high quality public realm, based on placemaking, greening, accessibility, and design quality – supporting wider economic approach to city and local centre regeneration.
56. Some further examples of collaborative working are:
- Working with our neighbouring Vale of Glamorgan Council in 2020 delivering a major resurfacing scheme on Culverhouse Cross that benefitted both Cardiff and the Vale carriageways.
  - Obtaining One Planet Cardiff funding for innovative low carbon resurfacing on the A470 North Road in 2022 and carbon negative resurfacing trial utilising Biochar on Splott Road in 2023.
  - North Cardiff Woodlands Restoration Project – The Highway Infrastructure and Operations Public Rights of Way team in collaboration with Parks colleagues, Natural Resources Wales and The Wildlife Trust of South and West Wales have developed a strategy, signed a Memorandum of Understanding and built relationships with user groups to try and co-manage these woodlands for the benefit of all users and nature. The project needs Heritage Lottery funding to implement the shared vision and has reached the full application stage of the Heritage Lottery process which will be submitted in March 2024.
  - Working with Transport for Wales (TfW) for the electrification of the Core Valley Lines, engaging consultants to support Officers. Also, on the specification, procurement and

implementation of the Welsh Bus Data Service system that will provide a real-time bus information all of Wales.

- Monitor, Control and maintain Vale of Glamorgan Council and South Wales Trunk Road Agency traffic signals, CCTV, and Information signs in the vicinity of major strategic network interchanges.
  - Liaison with internal colleagues within PTE to assist them to implement the Stronger, Fairer, Greener Strategy, Corporate Plan, Transport White Paper, and One Planet Strategy through projects such as Churchill Way Canal and Cycling corridors thus ensuring that designs and the specification and implementation of highway electrical assets meets these ambitions.
  - Work with developers and colleagues in Planning and National Resources Wales to minimise impacts of street lighting on dark corridors in new developments. Also, for various design requirements such as proposed highway structures.
57. Further collaboration is also undertaken within the Civil Parking Enforcement (CPE) Service and the various bodies with which it is involved. These include:
- British Parking Association
  - PATROL – Parking and Traffic Regulations Outside London
  - Traffic Penalty Tribunal Annual Workshop
  - Moving Traffic and Parking Group – collaboration forum between local Authorities and Chipside
  - Welsh Government Blue Badge Group
  - DVLA - Devolved Power Partners Cluster Meetings
58. The CPE Management Team also attend and contribute to meetings with other stakeholders, e.g. both Welsh Government and Department for Transport have set up user groups on specific topics as they arise and have asked Cardiff Council to attend and sometimes present.

## **6. Bereavement & Registration Services**

59. Bereavement & Registration Services continues to provide key life event services to the whole of the Cardiff population and operates across a wide partnership with relevant bodies.
60. The Operational Manager for the service sits in a voluntary role as Chair of the Board of Directors of the Institute of Cemetery and Crematorium Management (ICCM) which is the largest provider of training, advice and information for Cemetery and Crematorium professionals throughout the UK.
61. The OM also engages at quarterly meetings with Welsh Government at the Cross-Party Funerals Group to discuss bereavement issues with Welsh Ministers and other stakeholders including religious groups and funeral directors. In addition to this he also attends the meetings of the Westminster based Burial and Cremation Advisory Group (BCAG) which serves to influence legislative, and standards changes around the whole funeral industry.
62. Bereavement Staff also regularly attend the South Wales Benchmarking group where local professionals discuss service provision, innovative ideas, industry changes as well as sharing key benchmarking data around service costs and fees. This information is relayed back to colleagues as part of the monthly operational team meetings.

63. The Registration Manager attends several groups which includes:
- All Wales Registration Group Meeting (quarterly)
  - National Fraud Champions Group (6 weekly)
  - South-East Wales Medical Examiners Stakeholder Group (bi-monthly)
  - National Qualification Verifier Certification Group (quarterly)
64. The Registration Manager is also the lead officer for Wales for the Digital Registration Service (DRS) and Cardiff Registration Service is about to begin as the Welsh pilot for this project, going live registering deaths via this new service with 9 other English Districts in the next couple of months.
65. We have a Data Sharing Partnership Agreement with Vale of Glamorgan allowing us to share registration information with each other for the benefit of our residents using our services.
66. The services both have a high-level strategy designed to ensure improvements are made for the benefit of our customers but also delivered in line with best practice set through the above national organisations and the legal requirements around these services. The strategies are live documents and updated as required to consider issues such as legislative or budget changes.
67. The strategy is reviewed and updated on a 5 yearly cycle and approved by the Cabinet member for the service, the latest draft is due to be published in April 2024. The strategy documents are formally reviewed and monitored for progress and risk purposes at quarterly Directorate Delivery Plan reviews and operational meetings and any significant issues escalated if required.

**(f) Value for Money**

68. The directorate works with the procurement team to meet the contract standing orders and procurement rules, to ensure open, fair, and transparent procurement. At times, external funding deadlines, can make this challenging. However early engagement and partnership with the procurement is seen as vital to address these challenges.
69. On larger projects the incorporation of quantity surveyors and costs consultants ensures effective controls and benchmarking. For example, recently an O & M contract, for the Lamby Way Solar Farm project has been vital in maximising performance and related income.
70. Utilising the Commissioning and Procurement “Office 365 PowerBi dashboard” the directorate reviews compliance and performance on a quarterly basis. This provides an opportunity to check and challenge areas of no or off contract and forward look for up and coming areas.

**Highways Asset Management Plan (HAMP)**

71. The Cabinet approved (May 2023) Highway Asset Management Plan (HAMP-3) describes how the Highway Infrastructure and Operations teams link through to the Council’s Corporate Aspiration exploring the opportunity to focus on aligning the HAMP with the wider corporate priorities found in the Stronger, Fairer, Greener vision. Also bringing the ‘Highway’ within the wider context of creating high quality public realm, based on placemaking, greening, accessibility, and design quality – supporting wider economic approach to city and local centre regeneration.
72. The HAMP, which includes all associated highway assets such as structures and street lighting, is designed to provide a strategy for investment. It identifies where the demands and

risks are and the approaches, including investment levels, that are required to manage the asset. It is widely recognised that the application of modern asset management practices can enable improved value for money. In these challenging times it is essential that the council embraces these methods and strives to ensure that every penny spent is invested as wisely as possible.

73. When taking the highway asset itself, numerous maintenance approaches are taken to ensure, from a whole life cost perspective, that the life of the asset is maximised. Methodologies such as micro asphalts and surface dressings may be introduced to prolong and preserve the existing surface for as long as possible before a more expensive resurfacing or worst-case scenario reconstruction, become necessary.
74. In addition, localised resurfacing work or patching may be undertaken. This is often a revenue spend and the decision to patch over resurface must be made to ensure that value for money is being achieved. Patching is, in general, a more expensive option due to mobilisation and labour and the associated economies of scale achieved from larger scale works. However, the decision on treatment type must include overall condition of the road, necessity, and the overall improvement each approach will achieve. It is therefore an engineering decision, based on condition, road type use etc, that must be assessed city wide, that will govern the treatments used to ensure that available funds are maximised and providing the best available value for money.
75. The HAMP adopts a steady state investment strategy. This is the finance required to maintain the asset in its currency condition, therefore neither improving nor deteriorating. This is an assessment network wide and not on individual roads or associated assets. The budget requirements to achieve steady state are set out and used in highlighting the corporate financial commitments required. It is however the decision of the Council on the level of investment it makes when considering the many demands of the authority and the economic climate.
76. The Highways team work closely with the corporate finance teams to ensure that the correct level of understanding is achieved and that risks are understood. The balance between revenue and capital spend is also carefully managed to ensure that all works are within the required legislative guidelines.

### **(g) Complaints Handling**

77. For the majority of complaints (those relating to Highway Maintenance, Traffic & Transportation and Planning), these once received are logged within our CIVICA Correspondence System and allocated to an appropriate officer responsible for the complaint subject matter. Responses are then considered, signed off and agreed by an Operational Manager before a response is sent to the complaint initiator. This process is similar for Bereavement, Registration & Dogs Home, however, these complaints are logged locally and not within CIVICA. Periodic reports are presented to Directorate Management Team meetings for review purposes and are available in the Directorate Delivery Plan as KPIs/Measures. Below is a table which includes the number of complaints received for PTE during 2021/22 and 2022/2023.
78. *It is anticipated that the Corporate Complaints Process will transfer to the new HALO Correspondence System by the end of January 2024, currently the majority of complaints are managed by Planning, Transport & Environment through an antiquated CIVICA Correspondence System, this transfer will result in a more streamlined and robust way of*

*managing complaints, i.e. through improved automation of complaints receipt, allocation and response. PTE was part of the pilot for rolling out the correspondence elements of HALO in terms of testing and working through the development stages, and in turn was successfully implemented within the directorate and indeed to the degree where bespoke dashboards have been created and implemented for oversight purposes.*

<b>Service</b>	<b>2021/22</b>	<b>2022/23</b>
Highway Maintenance	56	54
Planning (including Building Control)	48	28
Traffic & Transportation	184	241
Total	288	323
Number / Percentage of complaints responded to on time	<b>229 (79.5%)</b>	<b>254 (78.6)</b>
Bereavement & Registration	24	11
Dogs Home	3	0
Total	27	11
Number / Percentage of complaints responded to on time	<b>27 (100%)</b>	<b>11 (100%)</b>

### **Learning from complaints – Planning Transport & Environment**

79. A large number of complaints have previously been received concerning the criteria for abandoned vehicles. Although a vehicle may be parked in a location for a certain length of time, it does not necessarily mean it is abandoned. This can result in complaints being made against the Council as residents are not aware of the legislation that has to be followed before a vehicle can be considered abandoned. This issue has been alleviated to a certain extent with the introduction of a dedicated web page for abandoned vehicles, where all the relevant information (for what is classed as an abandoned vehicle) can be found.
80. In the context of resources and pressures, it is crucial to emphasise the constraints faced by staff. The workload associated with leading on important cross-cutting programmes of projects, managing complicated processes, managing correspondence, and addressing the concerns of the public can be difficult. Furthermore, these challenges significantly increase the likelihood of complaints. When processes are complex, and there are potential delays or misunderstandings, it is natural for stakeholders to express their dissatisfaction. Managing these complaints effectively requires a delicate balance of addressing concerns promptly, maintaining transparency, and demonstrating empathy towards viewpoints from the various parties concerned.

### **Learning from complaints – Bereavement & Registration**

81. The service area is still recovering from the pandemic. The register office has moved to registering deaths at Thornhill Bereavement Services Office following public requests to register elsewhere than City Hall and to have direct access to staff in Bereavement Services. This has been widely appreciated by those who wish to access the service and the response has been incredibly positive.
82. It is important to note that due to the high number of visitors to the service – with over 4,000 funeral services per annum, approximately 500,000 visitors to our sites, 9,000 registrations for births and deaths, and 1,500 marriages – the complaints are very minimal. Furthermore, Citizenship Ceremonies are also organised by the Register Office.
83. All customers using Bereavement Services receive a questionnaire following their funeral service to gauge satisfaction and seek their opinions on potential improvements to the



service. These comments are logged and monitored and considered for implementation by the management team in the service.

#### **(h) Planning, Transport & Environment Compliments**

Service	Number of compliments 2021/22	Number of compliments 2022/23
Planning, Transport & Environment	84	79
Bereavement & Registration	81	121
Total	165	200

#### **Compliment Example**

84. "I would like to personally thank (Council officer) for his help in resolving a problem with new lighting. We found that the new light illuminated our garden and conservatory which made our property insecure. Mr Jones acknowledged our problem, and I am pleased to say that the problem has been rectified in a short space of time. Excellent service, thank you."

#### **Legal Implications**

85. There are no direct legal implications from this report.

#### **Financial Implications**

86. The financial implications (if any) arising from this report have been contained within the body of the report.

#### **RECOMMENDATIONS**

87. That the Governance and Audit Committee considers and notes the content of the report.

**Andrew Gregory**  
**Director, Planning, Transport and Environment**

The following are attached:

**Appendix A - High Level Corporate Risks** (see separate document)

**Appendix B - Key Directorate Risks** (See separate document)

This page is intentionally left blank

# **Appendix A**

## **PTE Corporate Risk Register**

(Q2 23/24)

# Air Quality & Clean Air Strategy

**Description**

Air quality in Cardiff does not meet statutory requirements set by legislation and continues to have a detrimental impact on health for residents and visitors to Cardiff.

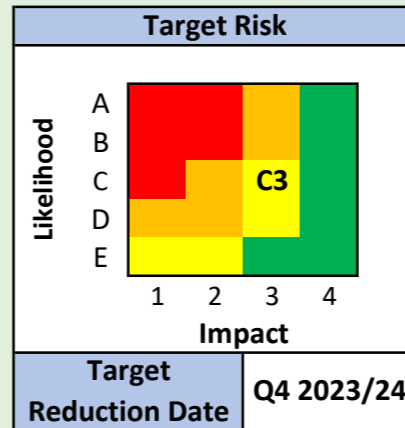
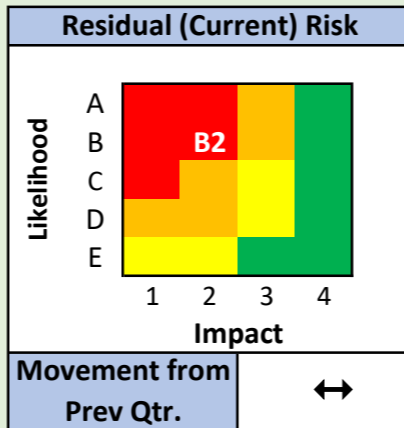
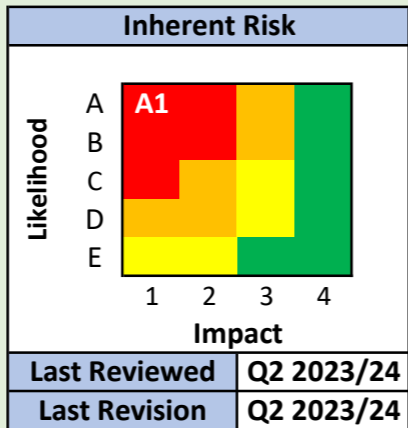

**Risk Owner(s)**

**Andrew Gregory**  
(Jason Bale)

**Councillor Caro Wild**  
Climate Change

**What we've done/are currently doing to achieve the Residual Risk Rating**

RESIDUAL RISK RATING AFTER CURRENT CONTROLS BELOW - B2 = LIKELY/ SIGNIFICANT

Monitoring

- Non-automatic nitrogen dioxide (NO<sub>2</sub>) monitoring sites at 136 locations.
- Data includes monitoring at schools as part of the TRO pilot projects at schools
- There are three live 24/7 monitoring stations:
  - Cardiff Frederick Street: measuring levels of NO<sub>2</sub>, PM<sub>10</sub> & PM<sub>2.5</sub>, SO<sub>2</sub>, CO and O<sub>3</sub>
  - Richard's Terrace, Newport Road: measuring levels of NO<sub>2</sub> & PM<sub>10</sub>
  - Castle Street measuring levels of NO<sub>2</sub> PM<sub>10</sub> and PM<sub>2.5</sub>
- 7 near real time indicative automatic analysers located predominantly in Cardiff's City Centre (5), one in Llandaff within the established AQMA and one in Canton on Lansdowne Road. These sites measure on a 24/7 basis, continuously monitoring for Nitric Oxide, Nitrogen Dioxide, Ozone, PM<sub>10</sub> & PM<sub>2.5</sub>, and does so every 15 minutes
- Additional 47 real time monitors installed across Cardiff, with support of One Planet Funding. This will be a 2 year pilot to assist the Council in improving collection of data including PM<sub>2.5</sub> and PM<sub>10</sub>. Data will be used to assess any additional areas of concern and trends in pollutant levels in existing AQMAs, to help identify and target further interventions.

Air Quality Management Areas (AQMA's)

- Cardiff has 4 existing declared Air Quality Management Areas (AQMA's) all as a result of elevated NO<sub>2</sub> concentrations from road traffic emissions.

Clean Air Plan

- Annual average for Castle Street = 33.8 µg/m<sup>3</sup> for NO<sub>2</sub> for 2022.
- Interim Castle Street Option still being implemented
- Mitigation measures to be detailed to WG if annualised results exceed agreed two threshold values of 35 µg/m<sup>3</sup> and 38 µg/m<sup>3</sup>.
- Construction of Ph1 City Centre West scheme (Wood St & Central Square) – substantially completed with snagging been undertaken. .
- Completion of Bus Retrofitting Programme of 49 buses – buses have been fitted with exhaust technology which reduces NO<sub>x</sub> emissions from the buses by 90%
- WG have approved updated Initial Plan and supported implementation of Option 1. The Minister has confirmed that in principle funding for the scheme will be provided by WG, subject to submission and approval of Final Plan. It is proposed to provide the updated plan within Q3.
- Following WG funding award, progression of EV Infrastructure has commenced on the council EV infrastructure road map, with the baseline assessment having been completed in Q2 2023/24.

Taxi Scheme:

Lease scheme launched January 2022 (note 5 vehicles only at this stage). Licensing Committee have now approved the proposal to remove the Hackney Carriage Limit for new plates to be issued. However this it is restricted that any new hackney carriage licences should only be issued to fully electric vehicles, or wheelchair accessible vehicles that are under 5 years old and meet the Euro 6 emission standard. Further revisions or update of scheme will need to be considered, including potential funding options to support upgrades to cleaner vehicles.

- Clean Air Strategy and Action Plan - A wider Clean Air Strategy and Action Plan has been developed to satisfy the requirements of LAQM. The strategy includes measures that will likely provide further AQ improvements incl AQMAs

**What we plan to do to meet target**

TARGET RISK RATING AFTER ACTIONS BELOW - C3 = POSSIBLE/ MODERATE

**Implement Clean Air Plan**

- Package of measures as detailed in Final Plan:
- Further assessment on Castle Street completed in February/ March and report was presented to Cabinet in April. Results show that Option 1 for all traffic still achieved compliance and owing to wider network impacts will be recommended as preferred option for Cabinet to approve. In Q2 WG provided approval of the updated Initial Plan and in a letter from the Minister, she detailed that funding for the scheme is agreed in principle.
- Subject to final decision being made on funding and approval of final plan the revised programme is anticipated;
  - Q3 2023/24 Commence tender process
  - Q4 2023/24/ Q1 2024/25 Complete tender process an New Cabinet Paper to award tender
  - Q2/3 2024/25 On site (with the road closed - this will be achieving compliance)
  - Q1 2025/26 Completion

**Clean Air Strategy and Action Plan**

- Roll out of measures (subject to grant bids/ funding)
  - Pilot project Non Idling Zones – Work with WG and Active travel team on potential, targeted around schools - Due to resource issues this project has not been fulfilled and will be potentially picked up in 23/24 subject to resources Q4 2023/24
  - Living Walls and other Green Infrastructure – this project has been completed and will be reported in the 2023 APR
  - Progression of EV Infrastructure - the completed road map is expected in Q4 2023/24
  - Review and where necessary update Air Quality Planning Guidance
  - Schools Active Travel - Continued support on TRO projects and expansion of monitoring associated with the project will be further supported as an when more schools come one line. Projects worked on to date in 22/23, will be reported in the 2023 APR
  - Behavioural Change Promotion, Consolidation of a dedicated Behavioural Change Programme linked to the Behavioural Change Strategy to be developed for One Planet Cardiff.

Review of Clean Air Strategy and Action Plan in 2023/2024 Q4 2023/24

**Potential Impact(s)**

**Health & Safety**

- No improvement to health
- Increased burden on health care
- Further deterioration of related health conditions

**Legal & Regulatory / Financial**

- Breach of legal / statutory requirements
- Potential significant financial penalty

**Type(s) of Impact**

- Health
- Regulatory
- Financial
- Strategic

- Reputational

**Linked Risks**

**Key Indicators / Measures used to monitor the risk**

- Implementation Plan for measures (funding dependent)
- Monitoring and Evaluation Plan for Clean Air Plan
- Ongoing monitoring and reporting under LAQM

# Climate Change - Biodiversity

**Description**

Cardiff is not able to manage the effects of climate change and energy security due to lack of future proofing for key (social and civil) infrastructure and business development.

**Potential Impact(s)**

- Loss of biodiversity leads to reduction in ecosystem resilience, and reduction in ecosystem resilience will compromise the provision of ecosystem services. These are the services or benefits which we gain from the natural environment.
- Ecosystem services include climate change mitigation and adaptation.
- Climate change mitigation includes the sequestration and storage of carbon by plants, especially long-lived species such as trees. Reduction of this ecosystem service makes it harder to reduce net carbon emissions. Annually Cardiff's trees (not including other aspects of green infrastructure) provide ecosystem services worth £3.31 million, of which £1.9 million is in carbon storage and sequestration (iTree Study, Sept 2018).
- Climate change adaptation services include storm water attenuation by vegetation and reduction of surface water volume through evapotranspiration
- Trees, green walls and green roofs allow cooling and shading, thereby mitigating the urban heat island effect which may become more prevalent with a warmer climate.
- Hotter summers also increase risk of aerial pollution through air stagnation, and green infrastructure can remove certain pollutants from the air as well as having a cooling effect.
- The National Priorities of the WG Natural Resources Policy include 'Delivering Nature-based Solutions'. Failure to ensure protection of biodiversity and ecosystem resilience risks failure to deliver these nature-based solutions, which include climate change mitigation and adaptation.

**Type(s) of Impact**

<ul style="list-style-type: none"> <li>Service Delivery</li> <li>Reputational</li> <li>Legal</li> <li>Financial</li> </ul>	<ul style="list-style-type: none"> <li>Health &amp; Safety</li> <li>Partnership</li> <li>Community &amp; Environment</li> <li>Stakeholder</li> </ul>
--	--

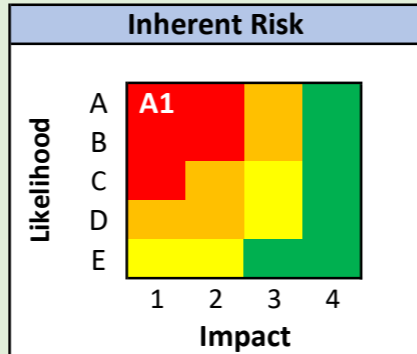

<b>Last Reviewed</b>	<b>Q2 2023/24</b>
<b>Last Revision</b>	<b>Q2 2023/24</b>

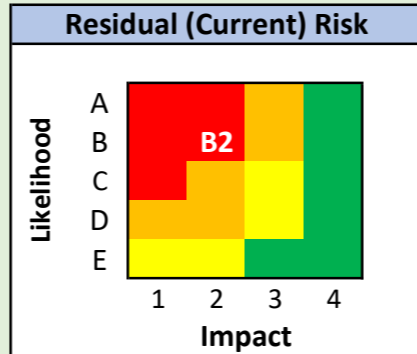

<b>Movement from Prev Qtr.</b>	↔
--------------------------------	---

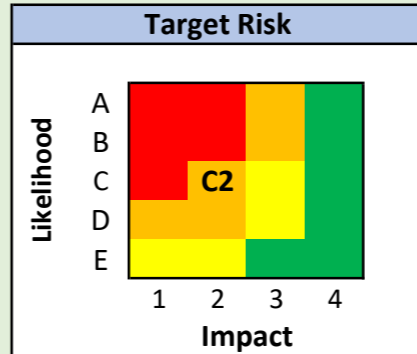

<b>Target Reduction Date</b>	<b>Q4 2023/24</b>
------------------------------	-------------------

**Risk Owner(s)**

<b>Andrew Gregory</b> (Simon Gilbert/ Jon Maidment)	<b>Councillor Caro Wild</b> Climate Change
--	---

**What we've done/are currently doing to achieve the Residual Risk Rating**

- Cabinet Report of 14/10/21 Recommended the Council sign the Edinburgh Declaration.
- Developed a Biodiversity and Resilience of Ecosystems Duty Forward Plan, to implement the statutory duty to seek to maintain and enhance biodiversity and in doing so to promote ecosystem resilience.
- Undertaken an 'iTree-Eco' study to look at the value of trees in terms of the ecosystem services that they provide.
- Working with neighbouring Local Authorities through the Local Nature Partnership Cymru project to share ideas and best practise for enhancing biodiversity across the City and identifying opportunities for cross-boundary projects to improve habitat and species connectivity and increase ecosystem resilience.
- Contributed to the Central South Wales Area Statement recently published by Natural Resources Wales.
- In June 2023 the Council agreed the Replacement LDP Preferred Strategy for consultation. This Strategy includes Strategic Policy SP19 which aims to ensure the Cardiff's green infrastructure assets are strategically planned and delivered through a green infrastructure network.
- The Coed Caerdydd Project has also resulted in further officer resource to support volunteer activity relating to tree planting and maintenance / aftercare and whereby grant funding has enabled the appointment of a Volunteer Co-ordinator on a fixed term contract up until July 2023.
- Successful appointment of Principal Planner (Ecology) in Q4 2022/23
- Regular meetings of Council "Green Infrastructure Officer Group" including colleagues from Planning, Parks, Drainage, and Public Rights of Way - re-commenced in Q4 2022/23 following appointment of Principal Ecologist post and ongoing
- Further funding has been obtained which has resulted in the LNP Co-ordinator post being extended at full time hours up until 31/3/23. This funding has also enabled the creation of a temporary Community Ranger Post until 31/3/23 to assist with the delivery of Local Places for Nature funded Projects.
- Deliver an enhanced tree planting programme - 2022/23 = 30,264 achieved (target 25,000)
  - 2023/24 - commenced the scoping exercise to inform the 23/24 planting programme and developing an action plan aimed at maximising opportunities for increase tree canopy within the highway / street scene. Investigations are underway to determine street tree planting locations in existing grass verges and retrofit planting locations within hard landscaped street scene.
  - Finalisation of Scoping Exercise / determine Planting Programme for 23/24 completed Q2 2023/24

**What we plan to do to meet target**

- A Habitat Regulations Screening Assessment has been completed on the Replacement LDP Preferred Strategy which was approved by Council in June 2023. Consultation on the Preferred Strategy and the background papers is running for 10 weeks to the 5th October 2023. **Q3 23/24**
- Update the Cardiff Biodiversity and Resilience of Ecosystems Duty Forward Plan, including the Action Plan, in line with legislative requirements - now pushed back to Q1 2024/25 due to resources and competing priorities, including preparation of the Nature Recovery Action Plan (NRAP) and LDP. **Q1 24/25**
- Recruitment of vacant Planner (Ecology) post and consideration of additional resources to enhance the Planning (Green Infrastructure) functions, subject to available candidates and resources.
- Officer attendance at all Wales Planning and Diversity Forum - **Q1, Q2, Q3, Q4 2023/24**
- Seek opportunities for partnership working under the 5 main themes of the South Wales Area Statement (building resilient ecosystems, working with water, connecting people with nature, improving our health, improving our air quality). - **ONGOING**
- Develop the local Nature Recovery Action Plan through the Local Nature Partnership (LNP) -- work is progressing well in partnership with the LNP steering group partners e.g. NRW, RSPB, WTSWW. Consultation workshops with the public and interest groups are planned for this summer to feed into the NRAP. **ONGOING**
- Discussions between the Council, Welsh Government and the Wales Council for Voluntary Action concerning LNP grant funding for a further 2 years is ongoing. - Formal confirmation has been received which will see the extension of LNP funding up until 31/3/25.
  - Finalise Scoping Exercise / determine Planting Programme for 23/24 - Q2 2023/24
  - Implement Planting Programme and action plan for maximising opportunities for increasing canopy within the highway / street scene - Q3/4 2023/24.

**Linked Risks**

Coastal Erosion  
 Air Quality  
 Business Continuity  
 Energy decarbonisation

**Linked Documents**

<https://www.evaccardiff.co.uk/>  
<https://www.cdp.net/en>

**Key Indicators / Measures used to monitor the risk**

Extent of Green Infrastructure in the City.

# Climate Change - Energy Security & Decarbonisation

**Description**  
Cardiff is not able to manage the effects of climate change and energy security due to lack of future proofing for key (social and civil) infrastructure and business development.

**Potential Impact(s)**

- Energy security (energy efficiency & decarbonisation of supply)**
- Inconsistent energy supply
  - Increased costs
  - Inability to deliver public services
  - Decrease in economic output
  - Disruption to the supply of utilities
  - Increased transport costs
  - Increased costs for heating / providing services to buildings
  - Increased fuel poverty

Page 42

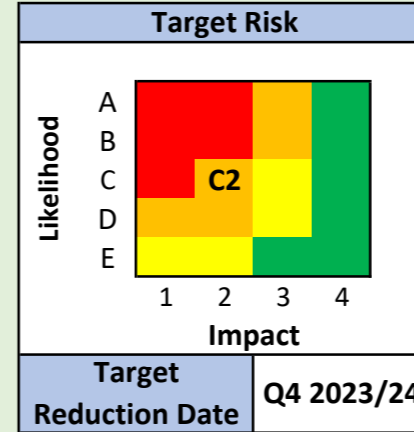
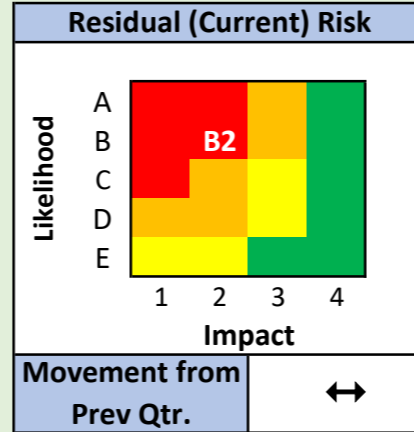
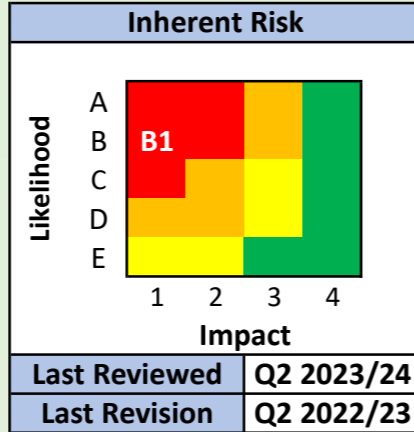

**Risk Owner(s)**

**Andrew Gregory**  
(Gareth Harcombe/ Liz Lambert)

**Councillor Caro Wild**  
Climate Change

**What we've done/are currently doing to achieve the Residual Risk Rating**

- Energy security (energy efficiency & decarbonisation of supply)**
- Climate Emergency Declared by Council
  - Council approved the final "One Planet Cardiff" Strategy on October 14th 2021 which addresses the Climate emergency and sets a pathway to a carbon neutral Council by 2030.
  - Established internal and external partnership and governance boards to steer our response to the climate emergency.
  - Energy efficiency measures being installed through Re-Fit and Salix projects - Now managed by FM
  - Phase 2 of Re-Fit project finalised and going through due diligence with Salix funding organisations - Schools focus for this tranche
  - NPS Consortium approach to purchasing energy to secure best prices - continuing by Economic Development
  - Lamby Way solar farm complete including the private wire connection to the Welsh Water Waste Treatment Works.
  - District Heat Network - Construction commenced on site in Jan 22 with a 3 year programme to completion
  - Carbon baselining and impact modelling reported to Welsh Govt and included in One Planet Cardiff. This has been used to inform the priorities in the action plan and progress will be monitored and reported annually.
  - Scoping additional carbon reduction projects for future action as part of the One Planet Cardiff project with key target areas confirmed in the One Planet Cardiff Action Plan - Funding secured to develop final business case for two major ne renewables schemes
  - Delivering Low Emission Transport Strategy - approved April 2018 and implementation of action plan underway:
    - first tranche and second phases of residential chargers delivered, and further phases in Council car parks and other residential areas underway - over 70 now installed
    - WG funding secured to install EV chargers at council buildings for small fleet vehicles
    - ULEVTF funding secured to install charging infrastructure in car parks and additional in-year funding awarded to implement Rapid charging infrastructure at Lamby Way depot for 12 electric refuse collection vehicles, and to engage consultant/ specialist to scope/design & specification for renewable connection & switch gear to produce green energy from landfill gas and/or the solar farm.
  - Working with the Cardiff City Region to develop a new domestic retrofit grant scheme using Energy Company Obligation funding. Plans for a major energy retrofit of council owned low-rise domestic blocks also in preparation and Welsh Government ARBED grant funding being targeted at "Hard to Treat" steel framed properties for implementation later this year. Outline of options to accelerate Domestic Retrofit presented to OPC Cex meeting April 23
  - OPC commits to a long term strategy for public engagement and behaviour change to build public resilience and positive action through advice and guidance and based on best practice and observed impact of initiatives elsewhere. This work is guided by advice from the Centre for Climate Change & Social Transformations (CAST) .

**What we plan to do to meet target**

- Energy security (energy efficiency & decarbonisation of supply)**
- Implement and monitor the One Planet Cardiff Strategy with carbon reduction targets and associated action plan for delivery over the to 2030 - Overall target March 2030 with specific project based targets stated in the detailed action plan **ONGOING**
  - Implement schemes to secure low/zero carbon development and retrofit in the Council's Estate - (Strategic Estates/ Schools/ Housing) by 2030
  - Promote and implement the approved policy position to guide new private sector development in the city - Ongoing - Relates to the Planning/development control process **ONGOING**
  - Complete Phase 1 of the Cardiff District Heat Network – by **Q4 2023/24**
  - Develop a pipeline of new renewable generation assets for cabinet approval in 22/23 - by **Q4 2023/24**
  - Deliver Steel Frame Retrofit scheme by Q4 24/25 and work with CCR to finalise arrangements for "LA Flex" Energy Company Obligation funded works and small measures retrofit initiatives by **Q4 23/24**
  - Electric Vehicle strategy - Proposals to convert council fleet to electric being reviewed/ assessed to allow for impact of Covid-19 and changes to requirements/ working practices **ONGOING**
  - Funding secured from Innovate UK to recruit a new post focussed on integrating Climate Change and Carbon reduction into Council's decision making and budget processes. Recruitment undertaken in Q2 2023/24, with programme of action developed by end **Q4 23/24**

**Type(s) of Impact**

- Service Delivery
- Reputational
- Legal
- Financial
- Health & Safety
- Partnership
- Community & Environment
- Stakeholder

**Linked Risks**

Coastal Erosion  
Air Quality  
Business Continuity

**Linked Documents**

<https://www.evaccardiff.co.uk/>  
<https://www.cdp.net/en>

**Key Indicators / Measures used to monitor the risk**

Energy use / renewable energy production of Cardiff Council



# Climate Change - Extreme Weather

**Description**  
Cardiff is not able to manage the effects of climate change and energy security due to lack of future proofing for key (social and civil) infrastructure and business development.

- Potential Impact(s)**
- Loss of life and risk to life
  - Damage to infrastructure & utilities
  - Service delivery
  - Increase in health related issues including air quality
  - Blight of development
  - Migration of ecosystems

Page 43

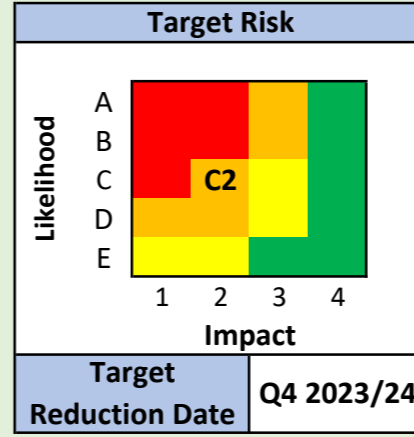
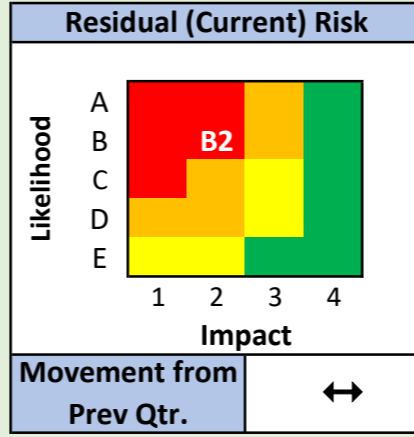
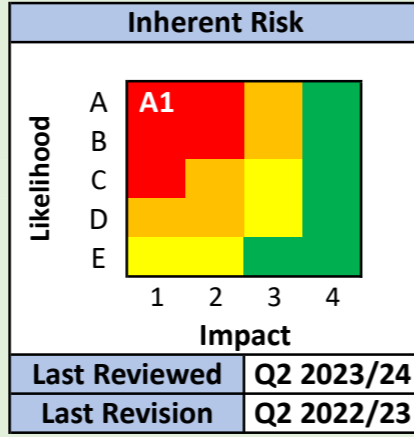

**Risk Owner(s)**

**Andrew Gregory**  
(EMU/Gary Brown)

**Councillor Caro Wild**  
Climate Change

**What we've done/are currently doing to achieve the Residual Risk Rating**

The Council has declared a Climate Emergency

**Extreme Heat**

- Working with Partners in the LRF to warn them of anticipated heatwave impacts upon vulnerable groups and support response to such a risk
- Supporting the enhancement of the public's own resilience through advice and guidance available from the EVAC Cardiff Website

**Extreme Cold/ Snow**

- Implementation of Council's Cold Weather Response Plans
- Winter Service review undertaken to consider the potential impact of Covid-19:
  - concentration made to build resilience into Winter Service as high risk to staff resource due to illness and the requirements of isolation
  - required training and staff rotas put in place, however there is a limited available resource with the required skillsets within the authority
  - investigations into feasibility/ availability of external assistance
  - Winter Service 21/22 delivered in line with statutory requirements

**What we plan to do to meet target**

**Extreme Heat**

- Develop a 20 year heat mitigation strategy for the city. Working with partner agencies and commercial stakeholders to support development of heat reduction programmes. - **2023/24**
- Engage with Welsh Government with in WLGA, and PSB to ensure consistent support in managing this risk ensuring the planning process works for all stakeholders to ensure we develop sustainable planning strategy's for future developments, planning the management of this risk (WG Technical Advice Note (TAN) 15) - a new updated Technical Advice Note TAN 15 is due to be published in June 2023 - postponed due to re-consultation and analysis, unlikely to come into force before end of this year - **Q4 2023/24**

**Extreme Cold/ Snow**

- Investigate further whether external assistance can be utilised/is available to build future resilience - risk remains for disruption to the service next winter if the current pandemic continues/ other new external factors emerge - **2023/24**

- Type(s) of Impact**
- |  |  |
|--|--|
| <ul style="list-style-type: none"> <li>• Service Delivery</li> <li>• Reputational</li> <li>• Legal</li> <li>• Financial</li> </ul> | <ul style="list-style-type: none"> <li>• Health &amp; Safety</li> <li>• Partnership</li> <li>• Community &amp; Environment</li> <li>• Stakeholder</li> </ul> |
|--|--|

**Linked Risks**

Coastal Erosion  
Air Quality  
Business Continuity

**Linked Documents**

<https://www.evaccardiff.co.uk/>  
<https://www.cdp.net/en>

**Key Indicators / Measures used to monitor the risk**

# Climate Change - Flooding

**Description**  
Cardiff is not able to manage the effects of climate change and energy security due to lack of future proofing for key (social and civil) infrastructure and business development.

**Potential Impact(s)**

- Flood & Storm**
- Loss of life and risk to life
  - Direct damage to property, utilities and critical infrastructure
  - Blight of Land and Development
  - Disruption to service delivery
  - Contamination and disease from flood and sewer water and flood on contaminated land
  - Increase in health issues
  - Break up of community and social cohesion
  - Increase cost of insurance
  - Migration of ecosystems
  - Associated impacts of river flooding not owned by NRW

Type(s) of Impact	
<ul style="list-style-type: none"> <li>• Service Delivery</li> <li>• Reputational</li> <li>• Legal</li> <li>• Financial</li> </ul>	<ul style="list-style-type: none"> <li>• Health &amp; Safety</li> <li>• Partnership</li> <li>• Community &amp; Environment</li> <li>• Stakeholder</li> </ul>

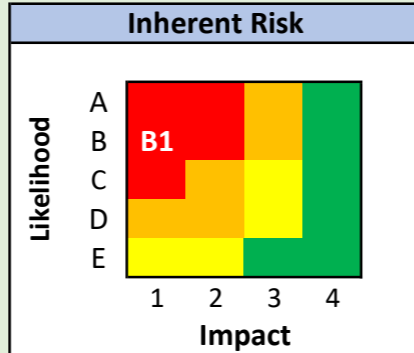

Last Reviewed	Q2 2023/24
Last Revision	Q2 2023/24

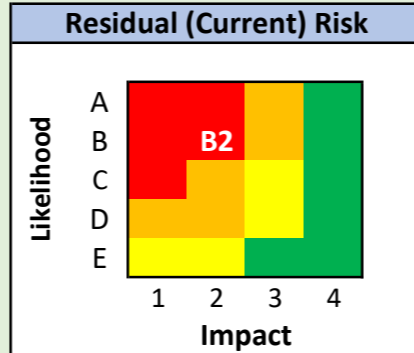

Movement from Prev Qtr.	↔
-------------------------	---

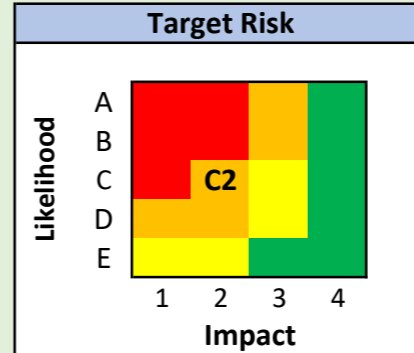

Target Reduction Date	Q4 2023/24
-----------------------	------------

**Risk Owner(s)**

<p><b>Andrew Gregory</b> (Gary Brown/ Simon Dooley Simon Gilbert/ Stuart Williams)</p>	<p><b>Councillor Caro Wild</b> Climate Change</p>
--	---

**What we've done/are currently doing to achieve the Residual Risk Rating**

The Council has declared a Climate Emergency

**Flood & Storm**

- Working with partners within the Local Resilience Forum (LRF) to support the management of this risk including supporting the emergency response to this risk
- Supporting the enhancement of the public's own resilience through advice and guidance available from the EVAC Cardiff Website
- Implementation of Schedule 3 of the Flood and Water Management Act 2010 requires all new development over 100m2 to implement sustainable drainage, resilient to flooding
- We have introduced Flood Incident Management software to provide better understanding of spatial distribution of flood events filtered by source, and determine priority areas for future flood alleviation schemes to be implemented (subject to WG funding bid opportunities). Successful funding bids were submitted and funding awarded in 20/21 for Business Justification Cases for a number of these schemes, with grant funding also now awarded for 21/22 for continuation of these schemes.
- Applications to WG were successful for grant funding in 2021/22 to support studies and implementation of localised flood prevention schemes.
- Ongoing CCTV and asset capture work taking place in drainage networks to review high risk areas.
- Asset management - Delivery of Flood Management and Coastal Improvement Schemes and rationalise/ prioritise gully maintenance schedule based on the outputs of the Flood Incident Management software - Phase 1 of new gully maintenance schedule completed.
- Highway Asset Management Plan approved by Cabinet in Q4 2022/23 - This captures the asset types, responsibilities and financial challenges.

**What we plan to do to meet target**

**Flood & Storm**

The following actions are ongoing :

- Completion by October 2023 of a draft combined Flood Risk Management Strategy and Flood Risk Management Plan as required by The Flood and Water Management Act (2010) and The Flood Risk Regulations (2009) respectively. The final strategy must be submitted to Welsh Government and published by March 2024 - The flood risk strategy will be delayed past Q3 2023/24 due to resource issues within this specialist area. Recruitment continues with reviews of post grades. Welsh Government have been made aware of the delays being experienced.
- Develop enhanced engagement programme with partners supporting the public in enhancing their own resilience - this will be a key aspect of the above Plan - initial discussions with Dwr Cymru/Welsh Water and Natural Resources Wales (NRW) have taken place, work is ongoing - Target **Q3 2023/24**
- Improve communication on what to do in a flood and raise awareness of risk - as above - initial talks underway to produce a role & responsibilities video, as well as flood safety guidance in co-operation with Dwr Cymru/Welsh Water, NRW and Blue Light organisations **ONGOING**
- Improve the service provided by the SuDS Approval Body (SAB) through additional resource - Recruitment remains unsuccessful, a grade review process is ongoing - **Q4 2023/24**
- Deliver guidance to increase standards and ease of development - in development **Q3 2023/24**

**Flood Risk Management Programme:**

- Phase 2 of new gully maintenance schedule delivered by Q3 2023/24
- The Flood Risk Management Team have been successful in achieving Welsh Government funding to undertake full business case development to identified flood risk areas in the City in 2023/24.
- Funding has been achieved to deliver property level flood protection at a number of locations. Some works have been delivered and others are ongoing during **Q2/3 2023/24**.
- Detailed design has commenced on the Whitchurch flood alleviation scheme (Greener Whitchurch). Consultation with Key Stakeholders and Local Members has commenced and is ongoing.
- Further FBC's are being developed for identified flood risk area in the city

**Linked Risks**

- Coastal Erosion
- Air Quality
- Business Continuity

**Linked Documents**

- <https://www.evaccardiff.co.uk/>
- <https://www.cdp.net/en>

**Key Indicators / Measures used to monitor the risk**

- Storm Events that meet silver & gold emergency intervention
- Annual number of flooded properties and severity (statutory reporting)
- Energy use / renewable energy production of Cardiff Council

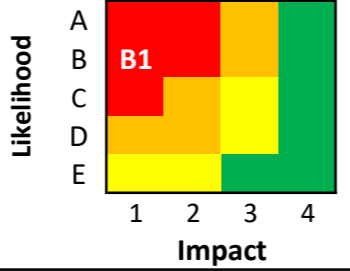
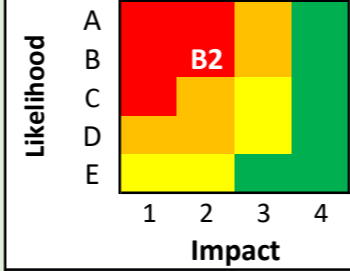
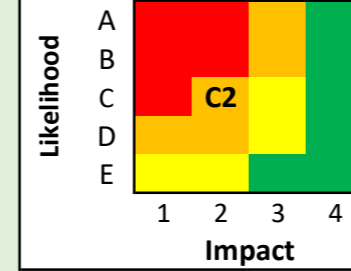

# Coastal Erosion

Description	Inherent Risk	Residual (Current) Risk	Target Risk	Risk Owner(s)									
<p>Breach of current defences resulting in widespread flooding (current defences are ad hoc and are in a very poor condition)</p>	 <p><b>B1</b></p>	 <p><b>B2</b></p>	 <p><b>C2</b></p>	<table border="1" style="width: 100%;"> <tr> <td style="width: 50%; text-align: center;"> <b>Andrew Gregory</b> (Matt Wakelam/ Gary Brown/ Simon Dooley)                 </td> <td style="width: 50%; text-align: center;"> <b>Councillor Caro Wild</b> Climate Change                 </td> </tr> </table>		<b>Andrew Gregory</b> (Matt Wakelam/ Gary Brown/ Simon Dooley)	<b>Councillor Caro Wild</b> Climate Change						
<b>Andrew Gregory</b> (Matt Wakelam/ Gary Brown/ Simon Dooley)	<b>Councillor Caro Wild</b> Climate Change												
	<table border="1" style="width: 100%;"> <tr> <td style="width: 50%;">Last Reviewed</td> <td style="width: 50%;">Q2 2023/24</td> </tr> <tr> <td>Last Revision</td> <td>Q1 2023/24</td> </tr> </table>	Last Reviewed	Q2 2023/24	Last Revision	Q1 2023/24	<table border="1" style="width: 100%;"> <tr> <td style="width: 50%;">Movement from Prev Qtr.</td> <td style="width: 50%; text-align: center;">↔</td> </tr> </table>	Movement from Prev Qtr.	↔	<table border="1" style="width: 100%;"> <tr> <td style="width: 50%;">Target Reduction Date</td> <td style="width: 50%; text-align: center;">2026</td> </tr> </table>	Target Reduction Date	2026		
Last Reviewed	Q2 2023/24												
Last Revision	Q1 2023/24												
Movement from Prev Qtr.	↔												
Target Reduction Date	2026												
	<b>What we've done/are currently doing to achieve the Residual Risk Rating</b>			<b>What we plan to do to meet target</b>									
	<ul style="list-style-type: none"> <li>Incident management arrangements are in place, which whilst not preventative, represent a level of emergency management for a flood and coastal erosion risk event occurring in a significant storm event. Coastal Defence Scheme:</li> <li>The Flood Risk Management Team are undertaking detailed design for the coastal defence scheme - the necessary works are holistic and cannot be phased, therefore residual risk rating cannot be lowered until the completed construction of the coastal defence scheme in its entirety.</li> <li>The inundation risk will be improved by implementing the coastal defence scheme, which will provide defence for a 1 in 200 year severe weather event, plus an allowance for climate change influence of 40%.</li> <li>The total costs associated with the Design, Early Contractor Engagement and Construction phases were originally estimated at £10.9m (Welsh Government 75% funding = £8.2m and CCC 25% funding = £2.7m)</li> <li>Formal application was submitted to Welsh Government (WG) under the WG Coastal Risk Management Programme and development of the Detailed Design and Full Business Case (FBC) was programmed for completion in May 2020, however was impacted by Covid-19.</li> <li>Work ongoing with Emergency Management to formulate interim measures.</li> <li>Due to the costs of funding the East side (Lamby Way), that WG will not fund, it has been removed from the scheme. Following completion of scheme the risk to properties will be addressed, however, a risk to significant infrastructure including Lamby Way landfill will remain in place, and is being dealt with as a directorate based risk.</li> </ul> <p>Scheme Delivery Progress update: At the request of WG, approval of the full business case and therefore financial confirmation was not provided until 2023/24:</p> <p>Key steps:</p> <ul style="list-style-type: none"> <li>Approval by Welsh Government of the FBC and funding allocation received Q1 2023/24</li> <li>Internal legal and procurement processes completed</li> <li>Contract awarded to Knights Brown</li> <li>Client (CC)/Contractor pre-contract meetings commenced</li> </ul>			<p>We will be designing &amp; delivering an effective coastal flood protection scheme as a matter of priority - Anticipated construction starting 2023, with completion 2025/26.</p> <p>Key steps:</p> <ul style="list-style-type: none"> <li>Commence construction - Anticipated on-site commencement date Q3 2023/24 following WG extension of funding programme due to various challenges. <b>Q3 23/24</b></li> </ul>									
	<b>Potential Impact(s)</b>	<b>Linked Risks</b>			<b>Key Indicators / Measures used to monitor the risk</b>								
	<ul style="list-style-type: none"> <li>Continued coastal erosion along the coast threatening the Rover Way Traveller site and critical infrastructure including Rover Way and the Rover Way/Lamby Way roundabout</li> <li>Erosion to two decommissioned landfill sites, with risk of releasing landfill material into the Severn Estuary and having significant environmental impacts</li> <li>Flood risk to 1,116 residential and 72 non-residential properties over 100 years, including risk to life, property, infrastructure and services</li> <li>N.B. the predicted rates of erosion threaten the Rover Way Travellers Site and the adjacent electrical substation within 5 years, and further release of large volumes of unknown tip material from the Frag Tip into the Severn Estuary.</li> </ul>	<p>Climate Change risks</p>			<ul style="list-style-type: none"> <li>Award of contract for detailed design and Full Business Case - achieved</li> <li>Completion of detailed design and Full Business Case by May 2020 &amp; submitted to WG</li> <li>Delivery programme of coastal protection scheme</li> </ul>								
	<b>Type(s) of Impact</b>												
	<ul style="list-style-type: none"> <li>Health &amp; Safety</li> <li>Health</li> <li>Reputational</li> <li>Financial</li> </ul>												

This page is intentionally left blank

# **Appendix B**

## **PTE Directorate Risk Register**

(Q2 23/24)

Appendix B - Key Directorate Risks:

Ref:	Risk Description:	Potential Consequence:	Inherent Risk Rating:	Current Mitigated Risk Rating:	Target Risk Rating:	Target Date:	Current Controls at Q2:	Proposed Management Actions at Q2:	Key indicators
PTE 32	<b>HIGHWAYS STRUCTURES</b>  Risk: Risk of collapse of major highways bridges and structures  Risk of deterioration of glued segmental structures	<b>Consequence:</b>  Health & Safety /Reputational/ Legal/ Financial/ Service Delivery/ Strategic  Failure/ Collapse of a bridge structure would result in catastrophic loss of life/ injury and have major impact in terms of disruption, service delivery and reputation, as well as major financial and legal implications  Deterioration of glued segmental structures, if identified, would have major financial and strategic implications	D1 = LIKELY/ MAJOR	E1 = VERY UNLIKELY/ MAJOR	E1 = VERY UNLIKELY/ MAJOR	Q4 23/24	<b>RESIDUAL RISK RATING AFTER CURRENT CONTROLS BELOW - E1 = VERY UNLIKELY/ MAJOR</b>  <b>Monitoring &amp; Review</b> <ul style="list-style-type: none"> <li>All Highways structures &amp; bridges monitored/ maintained through scheduled inspection regime/ related scheduled key element replacement e.g. joints</li> <li>Weight restrictions instated where necessary to mitigate any risk prior to works being undertaken</li> <li>Specialist invasive inspections undertaken to determine condition of structures built using glued segmental construction methods (e.g. leckwith/butetown viaduct) to test for deterioration - this is now a non approved construction method. Likelihood of structural failure/ deterioration is low, however the impact, should it happen, would be major</li> <li>Results from the first specialist &amp; comprehensive inspection of Leckwith/ Butetown viaduct have been reviewed and no concerns were raised.</li> </ul> <b>Funding</b> <ul style="list-style-type: none"> <li>Annual sums capital allocation utilised to implement works/ recommendations which come out of principal inspections - 5 year programme is in place to manage priority works</li> <li>One off pressure bids submitted for additional funding when necessary, due to scale &amp; cost should major works be required e.g. Millenium Walkway.</li> <li>Capital Programme allocation 23/24 onwards reprofiled in line with projected spend profile of new 5 year programme of priority works</li> </ul>	<b>TARGET RISK RATING AFTER ACTIONS BELOW - E1 = VERY UNLIKELY/ MAJOR</b> <b>Monitoring &amp; Review</b> <ul style="list-style-type: none"> <li>Continue with current controls</li> <li>Further specialist invasive inspections required for all glued segmental structures of same design to ensure structural integrity remains - future actions to be determined by results of inspections - Risk will remain until inspections of all type structures is completed – 2/3 years</li> <li>Works are progressing on key structures such as A48 Rhymney River bridge working with specialist consultants and bat related restrictions. Target date for structural improvement works 2023/24.</li> <li>Specialist inspections ongoing - any concerns to be escalated, however none to date</li> </ul> <b>Funding</b> <ul style="list-style-type: none"> <li>One off pressure bids to be submitted for additional funding as/ when required</li> <li>Capital Programme for 23/24 - carryover schemes from 22/23 ongoing on site, with planned new works to be finalised Q2/Q3 23/24</li> <li>Escalation to SMT - briefing note to be prepared capturing key points to facilitate discussion</li> </ul>	- scheduled principal inspections
PTE 43	<b>City Centre Transport Improvements incl delivery of supporting highway improvements for new Central Transport Interchange &amp; the delivery of Segregated Cycleways</b>  Risk: Network impact	<b>Consequence:</b>  - Negative impact on the traffic network  - Impact on bus services and journey time  - Impact on Taxi Rank Space (during construction)	A1 = VERY LIKELY/ MAJOR	B3 = LIKELY/ MODERATE	D3 = UNLIKELY/ MODERATE	Q4 23/24	<b>RESIDUAL RISK RATING AFTER CURRENT CONTROLS BELOW - REDUCED FROM A3 = VERY LIKELY/ MODERATE TO B3 = LIKELY/ MODERATE AS SOME SCHEMES ARE AT/ COMING TO END OF CONSTRUCTION PHASE, REDUCING NETWORK IMPACT SLIGHTLY</b>  <b>Bus Operator Engagement</b> - regular contact with bus operators to share construction phasing plans and identify issues on the network  <b>Internal Network Review Group</b> - Internal group of officers set up to monitor the network impacts  <b>Programme of Enabling and Mitigation Works</b> - A series of projects purposely set up to support and enable key strategic transport scheme. - Ad-hoc projects and network changes to directly tackle network impacts as and when they occur  <b>Monitoring &amp; On Site Staff Presence</b> - Regular traffic monitor via UTC Control Room, automatic and manual counting of junctions and links - Staff presence on site and deployment to hot spot areas where required	<b>TARGET RISK RATING AFTER ACTIONS BELOW - D3 = UNLIKELY/ MODERATE</b>  <b>Funding</b> - work with Finance and corporate finance to identify internal budgets to be used to pay for controls - Seek further funding e.g. external where possible/ opportunity allows  <b>Resource</b> - Approve extra staff resource to supplement and support the Transportation Programme Team - funding secured, recruitment in progress  - ongoing monitoring and review, especially in relation to programme delays resulting in extension of contract duration and prolonged network disruption - target reduction date pushed back in line with extended programme of schemes currently on site.	Continual monitoring of transport network via UTC Control Room and Monitoring Equipment installed as part of SMART Corridor Project  Regular engagement with Bus Operators to gauge journey time impacts and identify issue hot spots  Number of public complaints  Visual on-the-ground checks by staff
PTE 45	<b>Commutated Maintenance Sums (CMS)</b>  Risk: failure to meet statutory maintenance obligations due to lack of investment in new assets and their future management requirements	<b>Consequence:</b>  Health & Safety /Reputational/ Legal/ Financial/ Service Delivery/ Strategic	B2 = LIKELY/ SIGNIFICANT	C2 = POSSIBLE/ SIGNIFICANT	D3 = UNLIKELY/ MODERATE	Q4 23/24	<b>RESIDUAL RISK RATING AFTER CURRENT CONTROLS BELOW - C2 = POSSIBLE/ SIGNIFICANT</b>  <b>Mitigation:</b> <ul style="list-style-type: none"> <li>Review of assets undertaken - where necessary lesser assets have been shut down and/or removed</li> <li>Revenue implications of major capital schemes raised as a risk at Major Projects meetings with Corporate Finance</li> <li>Information submitted as part of annual capital bid process to feed into MTFP (currently £125K indicative allocation in 23/24 &amp; 24/25)</li> <li>Cabinet approval achieved to ensure that future maintenance of SuDS will be through developer supplied commuted maintenance sums (CMS) and the management/ maintenance undertaken in-house</li> </ul> <b>Background</b> <i>Cardiff Council has a statutory requirement to ensure its owned assets remain in a reasonable condition, are suitable for intended use and do not present any form of danger. It has become increasingly difficult to maintain existing highway assets in a reasonable condition within current budget allocations, in some instances lesser assets have been shut down and/or removed. That option is not available for key assets such as roads, footways, drainage systems, traffic signals, street lighting etc.</i> <i>To align to Welsh Government and Council ambitions, internally funded development, the demand for improved active and sustainable transport infrastructure, and legislation such as that around sustainable drainage, the revenue budgets must also be aligned to future demands.</i>  <i>As Cardiff Council continue to be successful in obtaining grants to build new infrastructure, it is clear from the grant provider, that it does not fund ongoing maintenance. Also, when Cardiff Council undertake redevelopments such as Central Square with high end materials, Intelligent Transport Systems (ITS), lighting and drainage systems, no increased maintenance budgets are provided.</i>	<b>TARGET RISK RATING AFTER ACTIONS BELOW - D3 = UNLIKELY/ MODERATE</b>  It is imperative, should Cardiff Council continue to develop at its current rate, and to be able to maintain the current deteriorating assets in a reasonable condition, an increase to maintenance revenue budgets is required, potentially in the form of commuted maintenance sums (CMS).  <b>Funding</b> <ul style="list-style-type: none"> <li>Continue to liaise with corporate finance as part of the 24/25 budget setting process - outcome Feb 2024</li> <li>Further Review/ assessment to be undertaken for the MTFP to determine impact of Capital Schemes &amp; future maintenance requirements (high end materials &amp; related assets)</li> <li>The Highway Asset Management Plan HAMP was presented to Cabinet in May 2023. The HAMP highlights the gap between current funding and steady state and requests the Council to consider additional funding options for future years to mitigate the cost increases and asset deterioration. There is a specific section on revenue funding and future needs within the HAMP - the approval of the HAMP will help to highlight pressures and support funding bids going forward</li> </ul>	- condition related data  - continued asset mgmt/ appraisal  - complaints/dissatisfaction of stakeholders  - success of pressure bids (internal & external)

Ref:	Risk Description:	Potential Consequence:	Inherent Risk Rating:	Current Mitigated Risk Rating:	Target Risk Rating:	Target Date:	Current Controls at Q2:	Proposed Management Actions at Q2:	Key Indicators
PTE 10	<p><b>Transport Improvements incl City Centre, Cycleways &amp; Active Travel and Bus Corridors:</b></p> <p><b>Risk:</b> Lack of funding to deliver the improvements needed</p>	<p><b>Consequence:</b></p> <ul style="list-style-type: none"> <li>- Failure to achieve the Stronger, Fairer, Greener Corporate Plan objectives</li> <li>- Failure to achieve air quality improvement target resulting in continued poor health impacts</li> <li>- City Centre Master Plan proposals - There is a risk that funding may not become available in time to enable bus priority and public realm works on Westgate Street to be progressed in time to coincide with completion of new Central Transport Interchange resulting in less effective impact on public transport</li> <li>- Failure to maximise mode shift from private car to public transport to achieve the 50:50 modal split target of the Local Development Plan</li> </ul>	A1 = VERY LIKELY/ MAJOR	C2 = POSSIBLE/ SIGNIFICANT	D3 = UNLIKELY/ MODERATE	Q1 24/25 (outcome of grant funding bids for 24/25)	<p><b>RESIDUAL RISK RATING AFTER CURRENT CONTROLS BELOW - C2 = POSSIBLE/ SIGNIFICANT</b></p> <p><b>Funding</b></p> <ul style="list-style-type: none"> <li>• Robust business cases prepared using WelTAG 2017 Welsh Government Guidance for the phasing of improvements to the City Centre to support funding bids</li> <li>• Annual funding bids to Welsh Government and Region submitted/G continue - residual risk may increase at Q4 subject to the outcome</li> <li>• GCF funding secured for Enabling/ mitigation works and matchfunding</li> <li>• In-Year funding bids submitted when opportunity arises for additional funding</li> </ul> <p><b>Programme - Progress &amp; Development</b></p> <p>City Centre:</p> <ul style="list-style-type: none"> <li>- Central Square scheme completion end March 22/23 with some additional costs incurred</li> <li>- Southern Interchange under construction, carryover scheme from 22/23 - scheme costs have significantly increased due to road condition</li> <li>- Other areas Weltag, modelling &amp; design - limited works able to progress due to increase in Southern Interchange costs impacting budget</li> <li>- CC East Ph1 (incl canal) construction ongoing - anticipated completion now Jan 2024 - costs have increased considerably on the scheme due to various factors, currently leaving a significant funding shortfall, hence the change of the risk rating from D1 (unlikely / major) to C2 (possible/ significant). PTE Finance have worked to mitigate this as far as possible but further work is required to manage the shortfall going forward, and to scheme completion.</li> <li>- Castle Street - still awaiting AQ funding confirmation from WG</li> </ul> <p>Cycleways &amp; Active Travel:</p> <ul style="list-style-type: none"> <li>- CW1.2 completed</li> <li>- Roath Park Cyclway tendered for Ph3 construction</li> <li>- Part funding award for CW2 Newport Rd - scheme programme currently being reprofiled in line with reduced allocation</li> <li>- AT15 Sanatorium Rd tendered for construction</li> <li>- Complete programme of Active Travel improvements being delivered under ATF Core grant</li> </ul> <p>Bus Corridors:</p>	<p><b>TARGET RISK RATING AFTER ACTIONS BELOW - D3 = UNLIKELY/ MODERATE</b></p> <p><b>Funding</b></p> <ul style="list-style-type: none"> <li>• Continue transport appraisal process to secure funding</li> <li>• Continue to work with City Region to secure City Deal funding</li> <li>• Seek funding contributions from Welsh Water for SUD's improvements</li> <li>• Secure GCF match funding - bids submitted for 23/24 onwards - awaiting outcome Jan/ Feb 2024</li> <li>• Timely and regular progress updates from external PM's/ QS's to be provided to PTE Finance - Monthly Reports to be provided, and any significant change in scheme forecast to be flagged immediately, to ensure budgets can be managed effectively and any funding issues mitigated as early as possible</li> <li>• Internal process to be more structured, with project information saved in one location and accessible to all relevant officers (Project Delivery and Finance) - commenced - will be phased approach with ongoing review</li> <li>• Further funding options to be explored to cover shortfall in Eastside scheme, including realignment of existing directorate capital budgets</li> <li>• Additional grant funding claims to WG submitted re 22/23 - still awaiting outcome which will impact current year position significantly subject to result</li> <li>• Continue to secure £106 funding through strategic developments in the Local Development Plan - ongoing</li> <li>• Review future rollout of SMART Corridors from pilot scheme outcomes</li> </ul> <p><b>Programme - Progress &amp; Development</b></p> <ul style="list-style-type: none"> <li>• Further detailed modelling and impact assessment ongoing</li> <li>• Continued stakeholder engagement - ongoing</li> <li>• Continue detailed design for all schemes - ongoing</li> <li>• Ongoing financial monitoring and management of funding.</li> <li>• Review resources(FTE/ type/ grade/ cost etc) necessary to deliver the programme over the next few years - recruitment programme ongoing.</li> <li>• Re-programming required due to COVID19 impact - ongoing</li> </ul>	<p>Amount of WG grant bid for/ received</p> <p>Amount of GCF bid for/ received</p> <p>No. &amp; Value of S.106 and other contributions</p>
PTE 21	<p><b>Delivery of Financial Savings targets (current &amp; future) &amp; monitoring of revenue expenditure:</b></p> <p><b>Risk:</b></p> <ul style="list-style-type: none"> <li>- Unachieved savings from previous &amp; current years having a detrimental impact on financial position</li> <li>- 'Invest to save' schemes not meeting savings targets or not being delivered on time</li> <li>- Unfunded / unforeseen financial pressures</li> <li>- Potential shortfall against income targets</li> <li>- Revenue implications of capital schemes</li> </ul>	<p><b>Consequence:</b></p> <ul style="list-style-type: none"> <li>- Continued financial overspend.</li> <li>- One off mitigation rather than recurring financial plan.</li> </ul>	B2 = LIKELY/ SIGNIFICANT	C2 = POSSIBLE/ SIGNIFICANT	C3 = POSSIBLE/ MODERATE	Q4 23/24	<p><b>RESIDUAL RISK RATING AFTER CURRENT CONTROLS BELOW - C2 = POSSIBLE/ SIGNIFICANT</b></p> <p><b>EOY 22/23 - Mth12 the Directorate reported a balanced position following the transfer of some budgets to reserves for future investment and resilience.</b></p> <p><b>Savings</b></p> <ul style="list-style-type: none"> <li>• Savings model accounts for and mitigates unachievable savings to ensure realistic savings plan</li> <li>• Finance Officers work closely with accountants to ensure that savings are identified and appropriately allocated</li> <li>• Closely monitoring - highlighting potential shortfalls - in process of identifying mitigations</li> <li>• Working with Cabinet Members and providing good evidence/ support through associated reports</li> </ul> <p><b>Invest to Save</b></p> <ul style="list-style-type: none"> <li>• Monthly monitoring &amp; reporting of 'Invest to Save' schemes:</li> <li>- scheme delivery progress - highlighting potential delays which will impact completion date and payback/ savings</li> <li>- income generation - highlighting any anticipated shortfall/ delay in income and identify any mitigation</li> </ul> <p><b>Emerging Financial Pressures</b></p> <ul style="list-style-type: none"> <li>• Monthly monitoring with Team leaders and OMs to ensure all financial pressures are highlighted as soon as understood &amp; known</li> <li>• Unforeseen/ unfunded costs flagged to Corporate Finance and impact on financial position - corrective action to mitigate where possible</li> <li>• Working closely with Corporate Finance to ensure appropriate Covid 19 costs are identified</li> </ul> <p><b>Income</b></p> <ul style="list-style-type: none"> <li>• Monthly monitoring with Team leaders and OMs to ensure all income shortfall issues are highlighted as soon as understood &amp; known</li> <li>• Analysis/ modelling undertaken to try to understand trends and project future patterns</li> <li>• Projected shortfall &amp; reasons flagged to Corporate Finance to ensure appropriate Covid 19 costs are identified</li> </ul> <p><b>Capital schemes</b></p> <ul style="list-style-type: none"> <li>• Revenue implications of major capital schemes raised as a risk at Major Projects meetings with Corporate Finance e.g: <ul style="list-style-type: none"> <li>- maintenance - materials spec of high end products</li> <li>- cleansing - new equipment required to service cycle lanes</li> <li>- staff resources - increased staff required to deliver cabinet objectives (Stronger, Fairer, Greener)</li> </ul> </li> <li>• Information submitted as part of capital bid process to feed into MTFP (currently £125k allocated in 23/24 &amp; 24/25)</li> </ul>	<p><b>Monitoring &amp; Mitigation</b></p> <ul style="list-style-type: none"> <li>• Continue to identify the financial impact of Covid 19 and the new norm, understanding current and predicting future trends to support the recovery strategy - ongoing (Increased costs/reduced income)</li> <li>• Monthly monitoring &amp; reporting - ongoing</li> <li>• Winter Maintenance – insufficient funds to fund existing programme, impact of 20mph</li> <li>• Identification of ageing fleet and replacement cost – review with CTS</li> <li>• Energy Inflation - Rate higher than budget allocation -Discussions with budget strategy ongoing</li> <li>• Residential Parking - Review and clarify activity and position 24/25 (in line with proposed price increase)</li> </ul> <p>The Directorate is currently identifying ongoing pressures identified above, the Directorate is developing a plan to potentially mitigate shortfalls.</p> <p><b>Invest to Save</b></p> <ul style="list-style-type: none"> <li>• As raised in CEX Budget Challenge meeting - Energy projects need to have remedies put in place so savings start to be achieved (Radyr Weir &amp; Solar farm) - Action for consideration: <ul style="list-style-type: none"> <li>- Should operational delivery of Energy projects sit in PTE or within FM/ Estates? Discussions ongoing - AG/GH to lead discussions - Q4 2023/24.</li> </ul> </li> </ul> <p>The energy manager has worked with partners to provide forecast trading position for all schemes. These have been discussed and reviewed with Corporate Finance - review ongoing.</p> <p><b>Revenue Implications of Capital Schemes</b></p> <ul style="list-style-type: none"> <li>• Ongoing Review of revenue implications for Highways maintenance/ Cleansing to better understand additional cost/ budget requirements to inform MTFP, to include; <ul style="list-style-type: none"> <li>- Scheme</li> <li>- Type of specialist treatment e.g. granite, segregated cycle lanes, SUDs</li> <li>- Construction completion date</li> <li>- Maintenance start date</li> <li>- Anything else deemed pertinent</li> </ul> </li> </ul> <p>Meetings are ongoing as scheme programme &amp; detail develops -</p> <ul style="list-style-type: none"> <li>• S.106 - review and alignment of spend profile with delivery programme to be undertaken as soon as resource allows - aim 23/24, with new management process to be implemented in 23/24</li> <li>• Review of contracts to be undertaken to ensure no maintenance costs are included as part of the capital works - ongoing</li> </ul>	<p>- Directorate Financial Position</p> <p>- Improvement against previous years unachieved savings target</p> <p>- Implementation of audit recommendations</p>
PTE 37	<p><b>Global Economic Issues (i.e. BREXIT/ COVID/ UKRAINE/ INFLATION etc)</b></p> <p><b>Risk:</b></p> <ul style="list-style-type: none"> <li>- adverse impact on supply chain/ suppliers, and specifically increasing financial pressures from rising product/ service costs and contract values, creating difficulties in delivering services and schemes to budget</li> </ul>	<p><b>Consequence:</b></p> <p><b>Service Delivery</b></p> <ul style="list-style-type: none"> <li>- inability/delays in getting supplies, parts &amp; equipment</li> <li>- increased breakdown/ downtime of equipment</li> </ul> <p><b>Financial</b></p> <ul style="list-style-type: none"> <li>- increased supplier/ import costs</li> <li>- Reduction in income from fees &amp; charges</li> <li>- Reduction in grant funding</li> <li>- Increase in costs (e.g. due to market changes / import taxes)</li> </ul> <p><b>Strategic/ Reputational</b></p> <ul style="list-style-type: none"> <li>- reputational consequence with citizens and key stakeholders</li> </ul>	B2 = LIKELY/ SIGNIFICANT	C2 = POSSIBLE/ SIGNIFICANT	D3 = UNLIKELY/ MODERATE	Q4 23/24	<p><b>RESIDUAL RISK RATING AFTER CURRENT CONTROLS BELOW - C3 = POSSIBLE/ SIGNIFICANT</b></p> <p><b>Review &amp; assurance</b></p> <ul style="list-style-type: none"> <li>• Reviews undertaken by all areas of directorate to determine key suppliers and any potential issues</li> <li>• Assurance sought from identified suppliers where any potential risk</li> <li>• Mitigation actioned where necessary/ possible i.e. sourced alternative suppliers/ stock piling</li> <li>• Work with procurement to find local/ alternative suppliers wherever necessary</li> </ul> <p><b>Monitoring &amp; Reporting</b></p> <ul style="list-style-type: none"> <li>• Ongoing monitoring &amp; review of expenditure and income</li> <li>• Working with Corporate Finance to forecast/ manage / mitigate any income shortfall/ increased costs</li> <li>• All issues reported and managed via DRR and associated escalation process, as necessary</li> <li>• An element of additional recurring funding received for 23/24, reducing risk and impact of Global economic factors, but financial pressures e.g. contract prices are still significant, hence risk remains</li> </ul>	<p><b>TARGET RISK RATING AFTER ACTIONS BELOW - D3 = UNLIKELY/ MODERATE</b></p> <p><b>Review &amp; Assurance</b></p> <ul style="list-style-type: none"> <li>• Ongoing monitoring &amp; review of expenditure and income</li> <li>• Ongoing work with Corporate Finance to forecast/ manage / mitigate any income shortfall/ increased costs</li> </ul> <p><b>Reporting</b></p> <ul style="list-style-type: none"> <li>• Any emerging issues to be reported and managed via DRR and associated escalation process, as necessary</li> <li>• WG Capital Grants - reduced amount of funding awarded in 23/24, with potential for further reduction in-year (tbc) <ul style="list-style-type: none"> <li>- increased tender estimates/ contract award values to be notified to WG for approval where necessary</li> <li>- reprofiling of schemes/ grant programme where necessary to keep within budget restrictions or see what can be pushed back to 24/25 where not already committed</li> <li>- reduction on grant/ changes in scheme programme will directly impact revenue position in terms of income (capital recharges and design fees) - this will need to be closely monitored and mitigated where possible</li> </ul> </li> </ul>	<p>- Directorate Financial Position</p> <p>- Programme delays</p> <p>- Increased rates/ contracts</p> <p>- Grant Reporting</p>

Ref:	Risk Description:	Potential Consequence:	Inherent Risk Rating:	Current Mitigated Risk Rating:	Target Risk Rating:	Target Date:	Current Controls at Q2:	Proposed Management Actions at Q2:	Key Indicators
PTE 15	<p><b>Metro:</b></p> <p><b>Risk:</b></p> <ul style="list-style-type: none"> <li>- risk of the specification for the Metro within the Wales &amp; Borders Rail Franchise not accounting for the full scope of improvements needed to support improved rail, light rail or tram services and access in Cardiff.</li> </ul>	<p><b>Consequence:</b></p> <ul style="list-style-type: none"> <li>- Significant risk of not achieving the step change in how people commute and travel around the city as envisaged by the Capital Ambition</li> <li>- Significant risk of not maximising mode shift from private car to public transport to help achieve the 50-50 modal split target of the Local Development Plan 2006-2026 and the Transport Vision to 2030 of Cardiff's Transport White Paper (25% car and 75% sustainable travel for Journeys to work).</li> </ul>	A1 = VERY LIKELY/ MAJOR	D1 = UNLIKELY/ MAJOR	E1 = VERY UNLIKELY/ MAJOR	<p>Phased reduction target (will not see a significant reduction for 3 years)</p> <p>E1 = 27/28 E2 = 28/29 E3 = 29/30</p>	<p><b>RESIDUAL RISK RATING AFTER CURRENT CONTROLS BELOW - D1 = UNLIKELY/ MAJOR Governance</b></p> <ul style="list-style-type: none"> <li>• Close liaison with senior officers in the Welsh Government (WG), Transport for Wales (TfW) and Local Authorities (LA's) in the Region</li> <li>• Working relationships with the Cardiff Capital Region City Deal, TfW and WG have progressed, enabling agreement on investments in the Central Interchange Transport Hub (Opening Summer 2023) and Central Station.</li> <li>• Strategic Programme Board established with associated working groups - for governance and working relationships with City Deal Partners, WG, TfW and appointed Franchise contractor Keolis Amey.</li> <li>• Overarching business case for the Metro, including the Cardiff Core Metro/Cross-rail, is being developed</li> <li>• Continued engagement with non-statutory Cardiff City Region Transport Authority as part of the City Deal at Member and Officer levels.</li> <li>• Working groups with TfW and TfW Rail have been established to progress the preparation of business cases for improvements to stations, new stations and line extensions in Cardiff.</li> <li>• Cardiff Council provided input and endorsement of South East Wales Transport Commission recommendations to WG for greater investment in sustainable travel including Cardiff Cross-Rail/Core Metro network extensions and new train stations. The Burns Delivery Unit is now progressing the study work towards delivery of the recommendations.</li> <li>• Working arrangements to progress improvements at stations have also been established and further study work is progressing by TfW and Burns Delivery Unit on new stations between Cardiff and Newport following funding allocation of £2.5m from the Department for Transport</li> </ul> <p><b>Current Study Work in Progress</b></p> <ul style="list-style-type: none"> <li>• Successful £50m Levelling up UK Government funding for first phase of Crossrail from Cardiff Central to Cardiff Bay supported by £50m match funding from the Welsh Government in January 2023.</li> <li>• North West Corridor Phase 1 Stage 2 WellTAG</li> <li>• Cardiff Crossrail Technical Feasibility Studies including Western Junction</li> <li>• Cardiff Central to Cardiff Bay is in concept design phase.</li> <li>• Cardiff to Newport corridor WellTAG Stage 2 concept design phase progressing.</li> <li>• Cardiff Metro Master Planning/Option Development for Cardiff Bay/Roath Dock</li> <li>• Newport Road Station Study commissioned by the WG Burns Delivery Unit.</li> <li>• Metro Enhancement Framework WellTAG studies between Cardiff and neighbouring Local Authorities.</li> <li>• Cardiff Parkway in St Mellons call-in currently being determined by Welsh Government.</li> </ul>	<p><b>TARGET RISK RATING AFTER ACTIONS BELOW - E3 = VERY UNLIKELY/ MODERATE Governance</b></p> <ul style="list-style-type: none"> <li>• Strategic Programme Board Meetings ongoing - Cardiff Metro Steering Group Meetings ongoing.</li> <li>• Core Valley Lines Transformation and Metro Central Development Programmes ongoing.</li> <li>• The Burns Delivery Unit and The Cardiff Capital Region (CCR) Metro Programmes ongoing.</li> <li>• Improvements to the South Wales Mainline Programme ongoing.</li> </ul> <p><b>Planned Study work</b></p> <ul style="list-style-type: none"> <li>• Further extensions as part of the Core Metro/Cross-rail will involve further study work for the section Radyr to Coryton. Discussions with TfW and Velindre on future study work have been progressed.</li> </ul> <p>At the appropriate time, the Council will need to support bids for funding to progress the Metro schemes. This will need to be reported to Cabinet taking into consideration the Cabinet Reports of Feb 2014 and June 2021. Key projects requiring funding include:</p> <ul style="list-style-type: none"> <li>• Phase 1 Cardiff Crossrail City Centre to Cardiff Bay Metro by 2026;</li> <li>• Phase 2 southern section of Crossrail by 2028;</li> <li>• Phase 1 of Northwest Corridor by 2025;</li> <li>• New stations at Crwys Road, Butetown and Cardiff Parkway in St Mellons by 2024;</li> <li>• New stations at Velindre, Ely Mill, Roath Park, Gabalfa, Newport Road and Pierhead Street by 2025;</li> <li>• A Bus Strategy, including Park and Ride for Cardiff is being prepared for completion in Q3.</li> <li>• Phased implementation of sustainable transport improvements to the Eastern Corridor by 2030;</li> <li>• High-quality bus and cycling routes between Cardiff and Newport by 2025.</li> <li>• Integrated ticketing trial with TfW between Cardiff and Newport in 2023/24.</li> <li>• Mobility as a Service (MaaS) being progressed by TfW.</li> </ul>	<ul style="list-style-type: none"> <li>- Agreement of governance and working arrangements</li> <li>- Agreement of a programme of Metro improvements</li> </ul>
PTE 12	<p><b>Delivery of phased programme of well-maintained highway asset and public realm:</b></p> <p><b>Risk:</b></p> <ul style="list-style-type: none"> <li>Investment levels do not meet steady state / improving asset levels.</li> </ul>	<p><b>Consequence:</b></p> <ul style="list-style-type: none"> <li>- Asset continues to deteriorate placing a future financial, as well as reputational risk on the Council.</li> </ul>	B1 = VERY LIKELY/ SIGNIFICANT	C3 = POSSIBLE/ MODERATE	D3 = UNLIKELY/ MODERATE	Q4 23/24	<p><b>RESIDUAL RISK RATING AFTER CURRENT CONTROLS BELOW - REDUCED FROM C2 = POSSIBLE/ SIGNIFICANT TO C3 = POSSIBLE/ MODERATE DUE TO INCREASED INVESTMENT IN 23/24 (SUBJECT TO FUNDING RINGFENCED FOR PRIORITY SCHEMES ONLY) - RISK WILL INCREASE IF INVESTMENT DIPS IN 24/25 Funding</b></p> <ul style="list-style-type: none"> <li>• Funding pressure bids have been submitted to support longer term financial model to maintain steady state (capital &amp; revenue/ FRM)</li> <li>• FRM Funding has not been allocated in 23/24, placing further pressure on existing budgets when considering the management of a deteriorating asset.</li> <li>• Future maintenance of City Centre/ Cycleway schemes flagged as part of MTFP - £125K in 23/24 &amp; 24/25 currently allocated</li> <li>• The Highway Asset Management Plan HAMP 3 was approved by Cabinet in May 2023. The HAMP highlights the gap between current funding and steady state and requests the Council to consider additional funding options for future years to mitigate the cost increases and asset deterioration.</li> <li>• Additional £2M funding has been allocated in 23/24 towards Carriageway &amp; Footway improvements as a result of the approved HAMP, as well as a cost pressure uplift due (one year only) due to increased contract prices (approx 56% increase experienced).</li> <li>• Will continue to liaise with corporate finance as part of the 24/25 budget setting process - outcome Feb 2024</li> <li>• Invest to Save bid submitted for 24/25 for investment (over and above the normal cway allocation and outside of the HAMP) that would make future capital savings by prolonging the lifespan of specific roads using a specialist treatment, reducing the frequency required for resurfacing (lasts up to 3 times longer). This treatment can only be used on roads that are in a good condition on application, and would be targeted at specific high traffic A roads - awaiting bid outcome.</li> </ul> <p><b>Programme &amp; Monitoring</b></p> <ul style="list-style-type: none"> <li>• Projects such as LED street lighting investment and infrastructure projects being delivered to improve the position.</li> <li>• A48 Barriers replacement and Eastern Ave Street Lighting &amp; Cabling - design now progressing following procurement and covid delays</li> <li>• AMX asset management is in place for assets and information on assets is being collated so asset data and performance is held for informed decision-making, allowing investment in key areas.</li> <li>• Patching and Preventative Treatment programme is supporting the delay of investment in highways assets. However, this is not a replacement to steady state investment.</li> <li>• Ongoing programme of new C/way &amp; F/way works being delivered within available budgets</li> </ul>	<p><b>TARGET RISK RATING AFTER ACTIONS BELOW - D3 = UNLIKELY/ MODERATE Funding</b></p> <ul style="list-style-type: none"> <li>• Ongoing review/ assessment to be undertaken re MTFP to determine impact of Capital Schemes &amp; future maintenance requirements (high end materials &amp; related assets)</li> <li>• Issue around Tree Cutting to be re-raised with Parks Services in Economic Development and Corporate Finance - Q3 23/24</li> </ul> <p><b>Programme &amp; Monitoring</b></p> <ul style="list-style-type: none"> <li>• Completion of any carryover schemes, plus Programme of new C/way &amp; F/way works to be tendered.</li> <li>• A48 Barrier design to be completed and works tendered - due to complexities in the project and the potential requirement, due to available road space, to combine with the replacement street lighting project design has been delayed. Tender anticipated Q3 2023/24</li> <li>• Eastern Ave S/L design to be completed and works to be tendered - as above - to be delivered in conjunction with the barrier scheme due to location of works - Q3 2023/24</li> <li>• Ongoing work to continue looking at how Developments and projects can support improving highway assets</li> </ul>	<ul style="list-style-type: none"> <li>- condition related data</li> <li>- continued asset mgmt/ appraisal</li> <li>- complaints/dissatisfaction of stakeholders</li> </ul>
PTE 35	<p><b>SERVICE - Regulations on Sustainable Drainage Systems -</b></p> <p><b>Risk:</b></p> <ul style="list-style-type: none"> <li>- Liability of Cardiff Council adopting new SuDS on approximately 9% of new developments per year.</li> <li>- Impact of new approval process on resource</li> <li>- management of maintenance of SuDS</li> <li>- Resource for managing approximately 270 SAB applications per year based on Planning data for last four years.</li> </ul>	<p><b>Consequence:</b></p> <p>Health &amp; Safety /Reputational/ Legal/ Financial/ Service Delivery/ Strategic</p> <ul style="list-style-type: none"> <li>- Authority open to injury claims if adopted SuDS are not maintained.</li> <li>- New area meaning contractor readiness is unproven.</li> <li>- New area meaning lack of procedural or legal precedence in place and open to challenge.</li> </ul>	C2 = POSSIBLE/ SIGNIFICANT	C3 = POSSIBLE/ MODERATE	D3 = UNLIKELY/ MODERATE	Q4 23/24	<p><b>RESIDUAL RISK RATING AFTER CURRENT CONTROLS BELOW - C3 = POSSIBLE/ MODERATE SuDS Adoption</b></p> <ul style="list-style-type: none"> <li>• SuDS adoption process established in partnership with other Council departments and teams.</li> <li>• Senior managers in PTE have worked with Legal to define an approach to take forward to SMT and Cabinet in Qtr3 2021/22. - Cabinet report was submitted in November 2021. The requirement for commuted maintenance sums for future SuDS maintenance was approved as the approach to be taken for future qualifying developments.</li> </ul> <p><b>Resource</b></p> <ul style="list-style-type: none"> <li>• establish online application form with StarTraq system.</li> <li>• Capital Ambition Delivery Team supporting forecast of applications, digital support, fee structure and workshops to bring Council teams together in establishing new processes.</li> <li>• Recruitment of administrative and technical staff to manage workload.</li> <li>• Use of StarTraq as document management system.</li> <li>• Implemented Pre-application charging system.</li> </ul> <p><b>Maintenance</b></p> <ul style="list-style-type: none"> <li>• Working with insurance provider to ensure a robust maintenance regime that will mitigate the risk of any claims.</li> <li>• Cabinet approval achieved to ensure that future maintenance of SuDS will be through developer supplied commuted maintenance sums (CMS) and the management/ maintenance undertaken in-house</li> </ul>	<p><b>TARGET RISK RATING AFTER ACTIONS BELOW - D3 = UNLIKELY/ MODERATE SuDS Adoption</b></p> <ul style="list-style-type: none"> <li>• Develop robust Cardiff SuDS standards with strong health &amp; safety principles - ongoing</li> <li>• Implement GIS tool for risk assessment of individual sites in line with the Welsh Government Standards - ongoing</li> <li>• Working with Legal to construct a formal adoption agreement - agreement to be completed Q1/2 2023/24</li> </ul> <p><b>Resource</b></p> <ul style="list-style-type: none"> <li>• Development with Planning and Building Control of iDOCS system - long term strategy - ongoing</li> <li>• Impact of SAB legislation and related requirements on resource being reviewed - funding options being investigated &amp; considered for additional support - ongoing</li> <li>• Additional resources into the SAB team being pursued due to increasing demand. Resource to include 1No.G8, G7 and 2No.G6 for inspection to include Coal Tips - ongoing but with limited success to date in the SAB Officer role, applications have not warranted interviews</li> <li>• Still unsuccessful in recruitment in Q4, Team Leader meeting with J6 team to look at options for role and grade review. Recruitment to continue into 2023/24</li> </ul> <p><b>Maintenance</b></p> <ul style="list-style-type: none"> <li>• Develop robust SLAs and maintenance regime agreement for landscaping contract scenario- ongoing</li> <li>• Agreement for the mechanism and future maintenance responsibility of SuDS related to the legislative requirement of compulsory adoption</li> <li>• Once funding is at appropriate levels look to increase resource in the Operational teams to enable the maintenance of new SuDS features.</li> </ul>	<ul style="list-style-type: none"> <li>- SAB applications processed and approved or declined within 7 weeks.</li> <li>- Phase 2 milestones agreed by Jan '19</li> </ul>

Ref:	Risk Description:	Potential Consequence:	Inherent Risk Rating:	Current Mitigated Risk Rating:	Target Risk Rating:	Target Date:	Current Controls at Q2:	Proposed Management Actions at Q2:	Key Indicators
PTE 46	<b>SUPPORTED BUS SERVICES</b>  Risk: Reduction in bus services in Cardiff as a result of a reduction in Welsh Government revenue funding support to bus operators.	Consequence:  Reputational/ Legal/ Financial/ Service Delivery/ Strategic	C2 = POSSIBLE/ SIGNIFICANT	C3 = POSSIBLE/ MODERATE	D3 = UNLIKELY/ MODERATE	Q4 23/24	<b>RESIDUAL RISK RATING AFTER CURRENT CONTROLS BELOW - C3 = POSSIBLE/ MODERATE</b>  <b>Mitigation:</b> • BES3 ends on 24th July 2023. Bus Transition Fund (BTF) being made available in 2023/24 to continue supporting bus services as long as possible. Discussions ongoing with region. Shortfall in funding likely to limit how long the BTF can be supported in 2023. The WG has not made any funding commitment for 2024/25. • Letter sent to Ministers from the Cardiff City Region. • Reviewed existing FRM and BSSG supported services in preparation for 2023/24. • Liaised with corporate finance as part of the 23/24 budget setting process - outcome Feb 2023. • Work with the Welsh Government, Transport for Wales, Cardiff City Region and bus operators on revenue and capital funding, bus network design and bus infrastructure investment. • Assessment of local needs taking into consideration of the potential impact on the elderly, disabled, and people with mobility problems and School Transport. • Proposed promotion of bus use with bus operators, Welsh Government and Transport for Wales (funding and scope tbc). • Longer term supporting schemes to make bus use more convenient and attractive (e.g. ticketing, fare incentives, bus stop improvements, passenger information). • Working with TfW and Burns Delivery Unit on development of a travel App.  <b>Background</b> <i>The Bus Emergency Scheme (BES3) funding from the Welsh Government has been extended to 24th July 2023. The funding beyond this end date is proposed to be supported to a lower level requiring a reduction or de-registering of some bus services. Bus patronage has only returned to 60-70% of pre-COVID19 levels and this remains the case as of the end of June 2023. The costs of operating bus services is increasing significantly due to external economic influences on fuel, supplies and labour. Bus operators may begin de-registering bus services or reducing their frequency later in the year in advance of the funding ending in order to meet the 56 day notification requirements or for business planning reasons. Local Authorities are required to secure the provision of appropriate services to meet public transport requirements where it is socially necessary to have a bus service and the bus operators will not run a bus commercially. Where appropriate, local authorities step in and subsidise a bus service or part of a bus service taking into consideration funds available in accordance with the Transport Act 1985. Any assessment needs to consider the impact bus services being withdrawn may have in particular on the elderly, disabled, and people with mobility</i>	<b>TARGET RISK RATING AFTER ACTIONS BELOW - D3 = UNLIKELY/ MODERATE</b>  <b>Support Cardiff City Region Bus Group, WLGA, bus operators and public transport interest groups with lobbying the Welsh Government for revenue and capital funding for supported bus services and improvements to bus infrastructure.</b>  <b>Funding</b> • Ongoing joint working with WG, TfW, Burns Delivery Unit and Region on infrastructure improvements. • Work with TfW and Burns Delivery Unit on integrated ticketing trial between Cardiff and Newport. • Collaboration with the Region and Bus Operators on the transition to reduced funding by the Welsh Government. • Preparation of the Bus Strategy in 2023/24 (including Park and Ride) for completion in Q3.	Level of revenue funding support from the Welsh Government for bus operators.
PTE 42	<b>Workforce Planning Risk:</b> Failure to recruit graduates, apprentices and trainees within the directorate, and lack of representation in respect of equalities & diversity	Consequence:  Negative impacts on staff composition in relation to succession planning, skills, knowledge and experience, particularly in relation to promoting recruitment of younger people, or those from different and diverse backgrounds into the service to improve resilience	B3 = LIKELY/ MODERATE	C3 = POSSIBLE/ MODERATE	D3 = UNLIKELY/ MODERATE	Q4 23/24	<b>RESIDUAL RISK RATING AFTER CURRENT CONTROLS BELOW - C3 = POSSIBLE/ MODERATE</b>  <b>Workforce Plan</b> • Directorate and Team Workforce Action Plan developed • Directorate and Team target for recruiting Apprentices, Graduates and Trainees • Corporate support received for a number of apprentices within the directorate - work ongoing to identify other funding/ establishment opportunities to support creation of additional posts (25 posts targeted in addition to corporate supported ones) • All OMs confirmed feasible numbers of trainees and apprenticeships for their areas: - meeting with finance to discuss budget required to meet department target and how that might be met (w/c 24/01/2022) - 30 corporate funded posts available each year, OMs and PG working with HR to ensure bids submitted meet requirements to maximise opportunity for achieving corporate funding. The directorate applied for a number of corporate apprenticeship places. However high demand for funding across the Council has led to only a small number being funded this year.  <b>Review &amp; Resource</b> • HR support • Regular reviews at DMT • New OM (Sustainability Policy & Performance Manager) appointed in Q3 22/23, and review of risk undertaken in Q4 - Project now included in DDP for 23/24 • A directorate working group has been formed to develop the workforce planning plan.	<b>TARGET RISK RATING AFTER ACTIONS BELOW - D3 = UNLIKELY/ MODERATE</b>  <b>Workforce Plan</b> • Priority action to be included in workforce action plan • Adhering to team targets for recruitment in posts (subject to available funding) • Any vacancies/new posts that become available will be considered for apprenticeships, trainees and Welsh speaker essential roles. • Identify & prioritise certain areas where there is the highest workforce planning risk e.g. operational • Self funded apprenticeships and trainees can be from outside of the Cardiff area - this will widen the audience for recruitment where we have struggled to get applicants when Cardiff only  <b>Review &amp; Resource</b> • Review of finances and other resources • Review of establishment to identify potential opportunities • Firming up mentoring requirements • Review of progress will be managed through DDP reporting • The directorate working group has connected with corporate equalities and diversity leads in the development of the project brief and is currently engaged with WLGA seeking funding to support the project - ongoing. • Research with managers has been undertaken and highlighted a number of constraints which are considered to affect recruitment & retention - this will be investigated to see how this can be addressed going forward.	Directorate DMT monitoring. Audit recommendation / Asset Management Action Plan. DDP
PTE 47	<b>CCTV PARKING FINES</b>  Risk: Civil Parking Enforcement is not currently able to redact video footage that is stored and that may need to be shared as evidence from CCTV parking fines	Consequence:  Reputational/ Legal/ Financial	B3 = LIKELY/ MODERATE	C3 = POSSIBLE/ MODERATE	D4 = UNLIKELY/ MINOR	Q4 23/24	<b>RESIDUAL RISK RATING AFTER CURRENT CONTROLS BELOW - C3 = POSSIBLE/ MODERATE</b>  <b>Mitigation:</b> • We do not capture anything not already in the public realm • We only share the footage when we need to • We only share the footage with the vehicle owner in question, it is not available publicly • We already redact photos therefore it is only the video footage that this would impact  <b>Background</b> <i>The issue of video footage in relation to CCTV parking fines has been raised by Information Governance as we currently do not have the ability to redact images, when supplied as evidence of the parking breach &amp; fine, to the vehicle owner in question.</i>	<b>TARGET RISK RATING AFTER ACTIONS BELOW - D4 = UNLIKELY/ MINOR</b>  • Service to put a process in place to manage video footage that is stored  • Service to explore options for mitigation, including the possibility of introducing redaction software - Risk is not significant as no new complaints received, however for best practise we are looking to improve our process. We are currently awaiting options and costs from our Moving Traffic camera supplier on redaction possibilities for all video clips.	No. of complaints received

Ref:	Risk Description:	Potential Consequence:	Inherent Risk Rating:	Current Mitigated Risk Rating:	Target Risk Rating:	Target Date:	Current Controls at Q2:	Proposed Management Actions at Q2:	Key indicators
NEW - PTE 48	<p><b>PASSENGER TRANSPORT</b></p> <p>Risk: contractor withdrawal from market, creating gap in availability of transport to undertake our statutory duty to provide transport.</p>	<p>Consequence: Reputational/ Legal/ Financial/ Service Delivery/ Strategic</p>	B3 = LIKELY/ MODERATE	C3 = POSSIBLE/ MODERATE	D4 = UNLIKELY/ MINOR	Q4 23/24	<p><b>RESIDUAL RISK RATING AFTER CURRENT CONTROLS BELOW - C3 = POSSIBLE/ MODERATE</b></p> <p><b>Mitigation:</b></p> <ul style="list-style-type: none"> <li>Work with operators to explore infrastructure works that can reduce operating costs and increase bus use</li> </ul> <p><b>Background</b> Ongoing uncertainty over amount of available funding from Welsh Government together with driver shortages and increased operating costs have led to fewer operators in the market generally. This is less of a problem in Cardiff than in areas where the bus market is dominated by SMEs.</p>	<p><b>TARGET RISK RATING AFTER ACTIONS BELOW - D4 = UNLIKELY/ MINOR</b></p> <ul style="list-style-type: none"> <li>Service to explore possible solutions, including but not limited to; <ul style="list-style-type: none"> <li>setting up own fleet and workforce to undertake the transport</li> <li>increase contract spend and budgets to attract contractors back into market to make it profitable to undertake contracts</li> </ul> </li> <li>develop a robust business case outlining options and proposals</li> </ul>	NEW - TBC at Q3
NEW - PTE 49	<p><b>PASSENGER TRANSPORT</b></p> <p>Risk: Commercial Bus Services withdrawn when Welsh Government emergency funding finishes leaving thousands of pupils without transport options to get to their school, with no alternative companies having capacity to undertake additional contracts required</p>	<p>Consequence: Reputational/ Legal/ Financial/ Service Delivery/ Strategic</p>	B3 = LIKELY/ MODERATE	C3 = POSSIBLE/ MODERATE	D4 = UNLIKELY/ MINOR	Q4 23/24	<p><b>RESIDUAL RISK RATING AFTER CURRENT CONTROLS BELOW - C3 = POSSIBLE/ MODERATE</b></p> <p><b>Mitigation:</b></p> <ul style="list-style-type: none"> <li>Increase in pupil season ticket rates for operators to increase operator income</li> <li>Work with operators to make timetables and routes more pupil friendly</li> <li>Continue to work with Region to lobby for increased levels of WG bus support funding</li> </ul> <p><b>Background</b> The continuing uncertainty over WG levels of bus funding, together with driver shortages and increased operating costs have led to operators reducing service frequencies and hours of operation, limiting the choice of transport options for some pupils In addition some operators have withdrawn from the market, limiting capacity and competition for contracts.</p>	<p><b>TARGET RISK RATING AFTER ACTIONS BELOW - D4 = UNLIKELY/ MINOR</b></p> <p><b>Mitigation:</b></p> <ul style="list-style-type: none"> <li>Increase in pupil season ticket rates for operators to increase operator income - ongoing review</li> <li>Work with operators to make timetables and routes more pupil friendly - ongoing</li> <li>Continue to work with Region to lobby for increased levels of WG bus support funding - ongoing</li> </ul>	NEW - TBC at Q3
PTE 50	<p><b>PASSENGER TRANSPORT</b></p> <p>Risk: Increased costs as a result of the new contracts when the main bus and minibus contracts are re-tendered in 23/24.</p>	<p>Consequence: Reputational/ Legal/ Financial/ Service Delivery/ Strategic</p>	B3 = LIKELY/ MODERATE	C3 = POSSIBLE/ MODERATE	D4 = UNLIKELY/ MINOR	Q4 23/24	<p><b>RESIDUAL RISK RATING AFTER CURRENT CONTROLS BELOW - C3 = POSSIBLE/ MODERATE</b></p> <p><b>Mitigation:</b></p> <ul style="list-style-type: none"> <li>Routes have been rationalised to reduce the number of vehicles needed and walking route improvements are being examined</li> <li>Enabling more pupils to use service buses with season tickets, however fewer alternatives available</li> </ul> <p><b>Background</b> Costs prices may increase by as much as 35% as a result of the new contracts and we may have to apply for increased Budgets to cover the costs of the new contracts, this won't be known until mid to late July this year, and then the same the following year when we tender the main bus and minibus contracts.</p>	<p><b>TARGET RISK RATING AFTER ACTIONS BELOW - D4 = UNLIKELY/ MINOR</b></p> <p><b>Mitigation:</b></p> <ul style="list-style-type: none"> <li>Ongoing review of routes/ rationalisation to reduce the number of vehicles needed</li> <li>Engagement with Active Travel colleagues to review walking route improvements - ongoing review</li> <li>External fuding bids submitted where possible/ appropriate for walking/ cycling routes as alternative mode of getting to school</li> </ul>	NEW - TBC at Q3



Ref:	Risk Description:	Potential Consequence:	Inherent Risk Rating:	Current Mitigated Risk Rating:	Target Risk Rating:	Target Date:	Current Controls at Q2:	Proposed Management Actions at Q2:	Key indicators
PTE 31	<p><b>Intelligent Transport Systems (ITS)</b></p> <p><b>Risk:</b> Deteriorating condition of Highways Electrical (Telematics) asset which is essential for the operational safety of the highway network and City Centre pedestrianised areas, including: - traffic signals - CCTV - LED VMS - RPS - North Rd Lane control System (tidal flow) - Bus RTI system - City Centre automatic rising bollards</p> <p>The risk also has a direct impact on other bodies/ stakeholders e.g. SW Police</p>	<p><b>Consequence:</b> equipment/ system failure resulting in; <b>Health &amp; Safety</b> - increased likelihood of accidents as a result of network failure <b>Legal / Regulatory</b> - potential breach of statutory obligations under the Highways Act and Traffic Mgt Act 2004 <b>Reputational / Service Delivery/ Stakeholders</b> Persistent failures of the asset will result in major reputational damage based on, perception of public safety, resultant major road network congestion, reduction in CCTV coverage on the highway network and city centre pedestrianised areas and also the potential for possible risk to life and limb of catastrophic failure of the physical asset and safety critical control systems. This has a direct impact on other bodies/ stakeholders e.g. SW Police <b>Financial</b> - potential reactive realignment of budgets to cover emergency repairs <b>Strategic</b> - potential risk Corporate Plan/ Capital Ambition objectives</p>	B2 = LIKELY/ SIGNIFICANT	C3 = POSSIBLE/ MODERATE	E3 = VERY UNLIKELY/ MODERATE	Q1 24/25 (outcome of grant funding bids for 24/25)	<p><b>RESIDUAL RISK RATING AFTER CURRENT CONTROLS BELOW - REDUCED FROM B3 = LIKELY/ MODERATE TO C3 = POSSIBLE/ MODERATE DUE TO RTI FUNDING 23/24 &amp; 24/25</b></p> <p><b>Maintenance &amp; Obsolescence</b></p> <ul style="list-style-type: none"> <li>Existing maintenance contracts in place to maintain existing asset (revenue budget) – renewal ongoing for various elements (Bollards, Traffic Signals/ITS) <ul style="list-style-type: none"> <li>CCTV new awarded with cost increase <ul style="list-style-type: none"> <li>7 mth extension to ITS contract due to Covid 19 restrictions &amp; necessity of business continuity - no significant cost increase</li> </ul> </li> </ul> </li> <li>New contract being developed and let, return/award anticipated early 2022.</li> <li>Due to specialist technical nature, these assets have limited lifespan (10-20 years), with parts not available off-the-shelf and requiring significant lead time for design, procurement and installation.</li> <li>Obsolescence has become increasing issue due to move from analogue to digital systems, and environmental issues/ new regulations.</li> </ul> <p><b>Funding</b></p> <ul style="list-style-type: none"> <li>Capital annual sums allocation in place to cover replacement/ renewal of obsolescence and major catastrophic failure of asset, however demand from ageing asset far exceeds available budget, which covers Electrical (Telematics) / Butetown Tunnel/ UTC Traffic Control Room – some additional funding secured in 21/22-25/26 capital programme following pressure bid</li> <li>Additional Capital Bid submitted for programme of replacement over next 5 years &amp; matchfunding bid to WG submitted - consultation with WG to agree strategy has recommenced.</li> <li>N.B. without increased investment this risk is likely to increase in severity in future</li> <li>First two years of WG Transport Grant awarded for the programmed replacement of the Bus Real Time information system and displays (3 year programme).</li> </ul> <p><b>Asset Review</b></p> <ul style="list-style-type: none"> <li>Bus Real Time Information (RTI) system replacement is in progress.</li> <li>Scoping Report (Design) procured to determine exact specification requirements/ costs</li> <li>Integrated Mobility as a Service (Maas) phone travel app is in development by Transport for Wales funded by WG for phased implementation in 2023/24 alongside integrated ticketing trials.</li> </ul>	<p><b>TARGET RISK RATING AFTER ACTIONS BELOW - E3 = VERY UNLIKELY/ MODERATE</b></p> <p><b>Maintenance &amp; Obsolescence</b></p> <ul style="list-style-type: none"> <li>Continued maintenance - ongoing</li> <li>Monitoring of supply issues (availability/lead times) additionally impacted by Covid 19/ Brexit</li> <li>Squirrelling/ re-purposing of any spare parts following upgrades</li> </ul> <p><b>Asset Review</b></p> <ul style="list-style-type: none"> <li>Identify any assets which can be decommissioned/ removed and analyse risk of doing so - ongoing.</li> <li>Continue to improve asset register - ongoing.</li> </ul> <p><b>Funding</b></p> <ul style="list-style-type: none"> <li>Programme of replacing of RTI system (3 year programme)</li> <li>Seek ongoing funding for Northern Corridor Smart Corridor.</li> <li>Pressure bids for capital programme 22/23-26/27 subject to Cabinet approval.</li> <li>The identification of sources of reliable funding needed in order to finalise the scope of the ITS Strategy. The Road User Payment (RUP) scheme may provide an opportunity subject to funding and approvals.</li> <li>Development of phased business cases including potential funding sources for ITS asset improvements.</li> </ul>	<ul style="list-style-type: none"> <li>condition related data</li> <li>continued asset mgt/ appraisal</li> <li>complaints/dissatisfaction of stakeholders</li> <li>success of funding bids (internal &amp; external)</li> </ul>

This page is intentionally left blank



**STRONGER  
FAIRER  
GREENER**



# Governance & Audit Committee Financial Update

23<sup>rd</sup> January 2024



#GweithioDrosGaerdydd  
#GweithioDrosochChi

#WorkingForCardiff  
#WorkingForYou

# Provisional Settlement Headlines – Revenue



**STRONGER  
FAIRER  
GREENER**

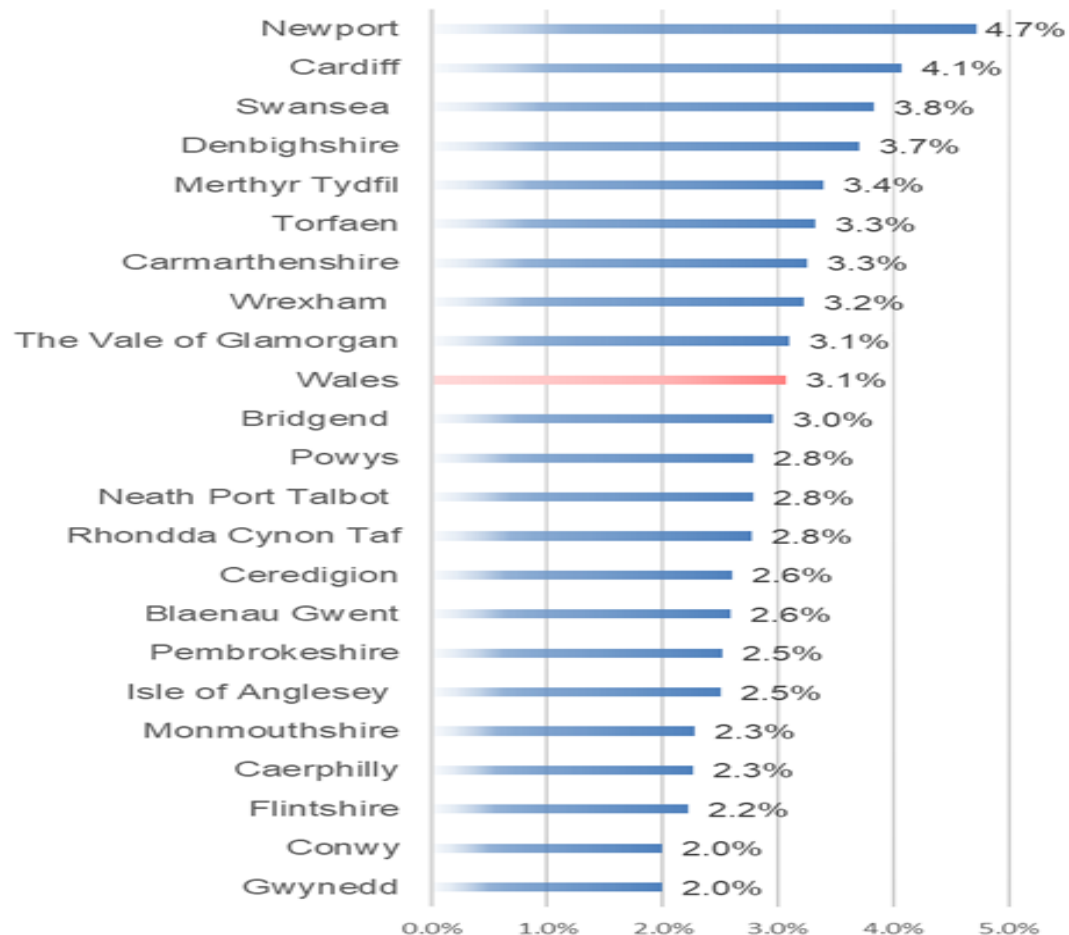

## Overview of Non-hypothecated Funding Wales

- Welsh average increase: 3.1%
- Range: 2.0% (Gwynedd & Conwy) - 4.7% (Newport)
- Floor funding mechanism in place at 2% (cost £1.3M)

## Cardiff

- Cardiff: 4.1% - second highest in Wales (Cash £24.246m) (last year increase was £48M)
- Positive formula impacts – population and pupil numbers
- Negative formula impacts – FSM , tourism and transport

No further year indicatives included

Some caution / risks – in particular around Specific Grants



# Budget Gap 2024/25

## (AT Provisional Settlement Announcement)

Elements of the Budget Gap 2024/25		£000
Budget Gap	Employee Related	22,000
	Prices	11,587
	Commitments & Realignments	11,687
	Capital Financing	3,591
	Demographic Pressures	7,213
	<b>Gross Pressures</b>	<b>56,078</b>
	Funding	(25,587)
	<b>Net Budget Gap</b>	<b>30,491</b>
Draft Strategy	Modelled Council Tax (+3%)	5,209
	Savings Required	25,282
	<b>Total</b>	<b>30,491</b>



**STRONGER  
FAIRER  
GREENER**



- Settlement reflected +4.1% (additional £5.171m including tax base)
- Savings requirement - £25.282 million (assuming 3% modelled Ctax publicly at this stage)

# Budget Modelling Update



**STRONGER  
FAIRER  
GREENER**



Page 58

	£000	Reflects
<b>Budget Gap</b>	<b>30,490</b>	Resources required less resource available
Council Tax increase	(5,209)	Draft only - modelled at 3%
Efficiency Proposals & Corporate Savings	(10,354)	No impact on Service Delivery
<b>Shortfall still to be addressed</b>	<b>14,927</b>	

The shortfall still to be addressed will be bridged through a combination of factors. Subject to consultation, these may include:

- Service change proposals to be included post budget consultation, if agreed.
- Finalisation of the position on schools' budgets for 2024/25
- Further scope to extend efficiency proposals.
- Further consideration of funding sources that are within the Council's control – including Earmarked Reserves and Council Tax.



#GweithioDrosGaerdydd  
#GweithioDrosOchChi

#WorkingForCardiff  
#WorkingForYou

# Budget Consultation - Overview



STRONGER  
FAIRER  
GREENER



## Two Stage Approach:

- **Ask Cardiff Survey 2023: *Helped shape budget priorities***
  - Ran from Monday 9<sup>th</sup> October to Sunday 19<sup>th</sup> November 2023
  - Included questions to identify budget priorities for both the 2023/24 financial year and the longer term.
  - 3,187 responses received.
- **Budget Consultation: *Seeking public views on specific proposals***
  - Running from Monday 8<sup>th</sup> January to Sunday 4<sup>th</sup> February 2024
  - Report on consultation findings to be published 19<sup>th</sup> February 2024.
  - Survey developed in accordance with legal and good practice considerations, including the “Gunning Principles”.



# Next Steps



**STRONGER  
FAIRER  
GREENER**



- Ongoing refinement and analysis of base requirements, savings proposals and modelling
- Consultation ends 4<sup>th</sup> February 2024 – Cabinet consider consultation feedback in drafting final budget proposal
- Late Feb / Early March – Budget Scrutiny
- Final Local Government Settlement not due until end of Feb / Early March
- Council consideration of Cabinet’s draft budget proposal – 7<sup>th</sup> March 2024
- Quarter 3 (Month 9) due into Cabinet shortly



#GweithioDrosGaerdydd  
#GweithioDrosochChi

#WorkingForCardiff  
#WorkingForYou



**GOVERNANCE & AUDIT COMMITTEE: 23 January 2024**

---

**INTERNAL AUDIT & INVESTIGATION TEAM - PROGRESS REPORT  
REPORT OF THE AUDIT MANAGER****AGENDA ITEM: 6.1**

---

**Reason for this Report**

1. The Terms of Reference of the Governance and Audit Committee requires that Members consider:
  - Updates on the work of internal audit including key findings, issues of concern and action in hand as a result of internal audit work.
  - Regular reports on the results of the Quality Assurance and Improvement Programme (QAIP).
  - Reports on instances where the internal audit function does not conform to the PSIAS and Local Government Application Note (LGAN) considering whether the non- conformance is significant enough that it must be included in the Annual Governance Statement.
  - The Counter-fraud strategy, actions, and resources.
2. A progress report has been prepared to provide the Governance and Audit Committee with an update on the work and performance of the Internal Audit and Investigation Teams. This progress report covers the period from 1 October - 31 December 2023, and follows the updates provided in the last Committee meeting held on 28 November 2023.

**Background**

3. The Governance and Audit Committee approved the Audit Charter and the risk-based Audit Plan for 2023/24 on 21 March 2023 respectively. At this time the planned activity of the Investigation Team was also provided for consideration.
4. The Internal Audit Progress Report (**Annex 1**) sets out performance in relation to the Internal Audit Plan. It summarises the work performed, the priority recommendations raised, the critical findings, emerging trends, and relevant value for money findings across the Council for the assurance of the Governance and Audit Committee.

5. The Investigation Team Progress Reports (**Annex 2**) focuses on proactive and reactive fraud awareness, detection, and investigation activities, including participation in initiatives, such as National Fraud Initiative (NFI) data matching exercises.
6. As part of progress updates, there is an opportunity to consider emerging risks, issues, and sources of assurance, and to potentially refocus priorities. Prior to presenting to Committee, progress reports are discussed with the Corporate Director Resources.
7. The Internal Audit Section reports to the Audit Manager. To meet the provisions of Public Sector Internal Audit Standards (PSIAS 1100 - Organisational Independence), the Audit Manager is not responsible for managing any functions beyond the Internal Audit and Investigation teams. The Audit Manager reports administratively to the Head of Finance and functionally to the Governance and Audit Committee for audit-related matters. There have been no impairments of independence or objectivity.

## Issues

### a) Audit

8. The introductory sections within **Annex 1** refer to the new Global Internal Audit Standards ([GIAS](#)) which have been recently published and will take effect during 2025. The PSIAS will be aligned to the GIAS to apply to internal auditing of public sector bodies. Further updates and briefings will be provided to Committee when updates are made to the PSIAS to define public sector application.
9. Section 2.1 'Current Activities' outlines how during quarter three the priorities and approach of the audit team were to deliver a combination of management support through consultation and engagement in high-risk areas, and to progress delivery of assurance engagements from the Audit Plan. Audit work continues to be undertaken predominantly on a desktop basis, although site visits are taking place for establishment audits, to observe the operation of physical controls or operating practices.
10. Section 2.2 'Resources', outlines that appointments made in the year to date, and how priority has been given to the development of new staff for their benefit, and for the longer-term benefit of the audit service overall. This was with the knowledge that providing detailed training and support would impact the capacity of the wider team as audit staff across the team have been involved. All new staff have been supporting the delivery of audit fieldwork and, the delivery of the Audit Plan will ramp up during quarter four, with posts now appointed to and with new staff having received initial training and development.
11. Section 2.3 'Annual Plan' advised Members that through engagement with senior officers within the Education Directorate, a request was made to add two advisory

audits to this year's Audit Plan, on 'schools education technology procurement' and 'school catering controls'. The request has been made by the Operational Manager who has taken on responsibility for these areas after the recent retirement of the Head of Services to Schools, and asked for an audit review of the controls in place. These reviews have been agreed by the Audit Manager in accordance with his delegation to approve audit engagements of no more than 10 planned audit days without seeking approval from the Governance and Audit Committee.

12. Delivery of the Audit Plan 2023/24 is proportionately lower than the pro rata target as at the end of quarter three, for which the reasons primarily relate to vacant posts being held during quarter one, followed by appointments being made during quarter two for which training, and development have been prioritised as outlined in section 2.2. 'Resources'. At the current stage in the financial year, the Audit Plan has been reviewed and prioritised to support a full audit annual audit opinion, through completing sufficient testing of fundamental systems, ensuring sufficient coverage in respect of planned corporate governance audits areas and an appropriate spread of service level audit work. The audits being targeted for completion to draft reporting stage in the remainder of the year are contained within Annex 1 – figure 4. The level of completion of the Audit Plan by 31 March 2023 will be affected by audit and client staff availability, as well as the complexity of issues that may arise during the audit fieldwork, however, any of the following audit that are not completed to draft report stage by the financial year end will be prioritised for completion in quarter 1 2024/25.
13. Section 2.7 'Critical Findings or Emerging Trends (Q2 2023/24)' outlines the findings of the two audits with opinions with 'insufficient with major improvement needed' issued over the reporting period, with details also provided on the findings and outcomes of an advisory review completed on the weighbridge software and associated controls.
14. Section 3 'Performance' provides the client feedback and wider performance against performance indicators which are deigned to be realistic and stretching. Audits will be allocated on a basis that provides the greatest assurance and value and mitigates any impairment to the annual opinion of the Audit Manager on the Council's control environment for 2023/24.
15. **Appendix A** shows a list of audits and their reporting status in the current year, as at 31 December 2023, in which 29 new audit engagements have been completed to at least draft output stage and 24 audit engagements from the prior year have been finalised. The current position for the full Audit Plan is shown in **Appendix B**.

#### Audit Recommendations

16. A summary of the audit recommendations and progress at the reporting date are provided within **Appendix C**. Full recommendation trackers on the recommendations open, and those completed since the last committee, are available for Governance and Audit Committee Members via a SharePoint site for information and reference.

## **a) Investigations**

17. Annex 2 outlines the activities of the Investigation Team in the year to date. For the year as a whole there are four hundred and fifty-two chargeable days available based on current resources, indicatively split between strategic (72 days) and operational activities (380 days).
18. Excluding blue badge and insurance data, which is not currently available, in respect of all other casework:
  - 118 cases were identified for investigation so far this year, compared to 82 for the same period last year.
  - 55 investigations are ongoing, compared to 43 for the same period last year.
  - 118 investigations have concluded, compared to 100 over the same period last year.
  - £523,888 has been attributed to concluded investigations, compared to £52,441 for the same period last year.
19. In addition to identifying and progressing investigation cases, the team has continued to provide counter-fraud advice, guidance, training, and support across the Council.
20. A number of the cases identified for investigation are generated by participation in the National Fraud Initiative (NFI) data matching exercises run by the Public Sector Fraud Authority and Audit Wales. Details of this work and the annual exercise on Council Tax and the Electoral Register are also provided in the Annex 2. Members are also advised that following consideration by Governance and Audit Committee in November, the Counter-Fraud, Bribery and Corruption Strategy and counter-fraud operational document updates were approved by Cabinet in December 2023.
21. The summary report in Annex 2 provides further details in respect of the above.

### **Legal Implications**

22. There are no legal implications arising from this report.

### **Financial Implications**

23. There are no direct financial implications arising from this report.

## **RECOMMENDATIONS**

24. That the Governance and Audit Committee notes and considers the contents of the Internal Audit and Investigation Team Progress Reports.

**CHRIS PYKE**  
**AUDIT MANAGER**

The following are attached:

**Annex 1 - Internal Audit Progress - Summary Report**

**Appendix A** Report Status as at 31 December 2023

**Appendix B** Audit Plan

**Appendix C** Recommendations Summary

[Committee Member Link to Recommendation Trackers](#)

**Annex 2 - Investigation Team Progress – Summary Report**

This page is intentionally left blank

# Resources Directorate Internal Audit Section



## Internal Audit Progress Report (as at 31 December 2023)

<b>INTRODUCTION</b>	<b>2</b>
Background	2
Independence and Objectivity	2
Continuing Professional Development	2
Conformance with Audit Standards	3
New Internal Audit Standards	3
<b>SUMMARY OF WORK PERFORMED</b>	<b>3</b>
Current Activities	3
Resources	7
Annual Plan	7
Critical Findings or Emerging Trends (Q3 2023/24)	10
Value for Money Findings (Q3 2023/24)	13
<b>AUDIT PERFORMANCE AND ADDED VALUE</b>	<b>13</b>
Added Value	13
Performance	14
Audit Plan Delivery	15
Recommendations	16
<b>CONCLUSION</b>	<b>16</b>
<b>Appendix A</b>	<b>Report Status as at 31 December 2023</b>
<b>Appendix B</b>	<b>Audit Plan</b>
<b>Appendix C</b>	<b>Recommendations Summary</b>

Prepared by: Chris Pyke, Audit Manager

# INTERNAL AUDIT PROGRESS REPORT

## 1. INTRODUCTION

### 1.1 Background

The Internal Audit Progress Report sets out performance in relation to the Internal Audit Plan. It summarises the work performed, the priority recommendations raised, the critical findings, emerging trends, and relevant value for money findings.

This progress report covers the period from 1 April – 31 December 2023, and follows the updates provided in the last Committee meeting held on 28 November 2023. This report is structured to provide a summary account of the audit activities, resources, outcomes, and progress made against the Audit Plan 2023/24.

The Audit Plan 2023/24 was approved by Committee on 21 March 2023. The Internal Audit Plan provides the framework for audit work each year and is aligned to the Council's corporate governance arrangements, whilst also being responsive to any changes to the risks faced by the Council during the year.

### 1.2 Independence and objectivity

The Internal Audit section reports to the Audit Manager. In line with the provisions of the Public Sector Internal Audit Standards (1100), organisational independence is maintained, as the Audit Manager is not responsible for managing any functions beyond the Internal Audit and Investigation teams. The Audit Manager reports administratively to the Head of Finance and functionally to the Governance and Audit Committee for audit-related matters. There have been no impairments of independence or objectivity.

### 1.3 Continuing Professional Development

Auditors have completed their year-end personal reviews and formalised their objectives for 2023/24. Prior to discussing performance, auditors updated their skills assessment in application of the IIA Professional Competencies Framework.

The results of personal reviews and skills assessments informed the year-end Audit Manager's review against the Quality Assurance and Improvement Programme (Standard 1300), from



which a generally strong baseline of knowledge and skills were recognised across the audit team.

#### 1.4 Conformance with Audit Standards

On an annual basis the Audit Manager completes an internal review against the CIPFA Local Government Application Note, which breaks down the conformance requirements of the Public Sector Internal Audit Standards (PSIAS). In addition to internal reviews, the PSIAS requires that external assessments are conducted at least once every five years by a qualified, independent assessor or assessment team from outside the organisation.

The latest 5-yearly external assessment was completed and reported to the Governance and Audit Committee in March 2023, led by the Chief Auditor in Monmouthshire / Newport Councils. The assessment reported no partial or non-conformance. One optional action was proposed and has been implemented, relating to the communication of the audit scope and objectives along with the risk, within audit outputs.

#### 1.3 New Global Internal Audit Standards

The PSIAS are derived from International Standards for the Professional Practice of Internal Auditing (ISPPA), established by the Institute of Internal Auditors (IIA). Further to the update to Committee in November 2023, and the resources and details provided at that point, the IIA has reviewed all elements of the International Professional Practices Framework (IPPF) including the ISPPA and has published the new [Standards](#). Further updates and briefings will be provided to Committee when updates are made to the PSIAS to define public sector application.

## 2. SUMMARY OF WORK PERFORMED

### 2.1 Current Activities

During quarter three 2023/24, the priorities and approach of the audit team were to deliver a combination of management support through consultation and engagement in high-risk areas, and to commence the delivery of assurance engagements from the Audit Plan.

The Internal Audit Team has continued to be available to provide advice and guidance on the design and implementation of effective controls, process changes and grant administration,

to achieve compliance and control, and arrangements for the effective prevention and detection of fraud.

Following the planned conclusion of the Audit Plan for 2022/23, a number of assurance audit engagements have commenced from the Audit Plan 2023/24. This work continues to be undertaken predominantly on a desktop basis, although site visits are taking place for establishment audits, to observe the operation of physical controls or operating practices.

The table below shows a list of audits and their reporting status in the current year until 30 December 2023, whereby 29 new audit engagements have been completed to at least draft output stage and 24 audit engagements from the prior year have been finalised. A summary of the audit outputs and opinions in the year to date is shown below.

**Figure 1.** Audit outputs and opinions (at 31 December 2023)

Status	Number of completed audits	Opinion				
		Effective	Effective with opportunity for improvement	Insufficient with major improvement needed	Unsatisfactory	No opinion given
Draft	8	3	3	2	0	0
Final	45	11	21	3	1	9
TOTAL	53	14	24	5	1	9
	29	New Audit Engagements completed				
	24	Finalised Audit Engagements from 2022/23				

**Figure 2.** 2023/24 Audit outputs and opinions (at 31 December 2023)

No.	Assurance Audit Engagement	Audit Opinion
1.	Performance Management – Governance and Legal Services	Effective
2.	Performance Management – Children’s Services	
3.	Performance Management – Adults, Housing and Communities	
4.	Performance Management – People and Communities	
5.	Performance Management – Planning, Transport and Environment	
6.	Taxation	
7.	Performance Management – Resources	
8.	Electoral Services	
9.	Information Governance	

No.	Assurance Audit Engagement	Audit Opinion
10	Insurance	
11.	Youth Offending Service	Effective with Opp' for Improv't
12.	Performance Management – Education and Lifelong Learning	
13.	Trade Waste	
14.	Housing Rents	
15.	Pest Control	
16.	Planning	
17.	Value for money in use of Council Vehicles	
18.	Facilities Management / Building Support	
19.	Purchasing Cards	Insufficient, Major
20.	Cyber Security (Schools) – ICT Managed Technology	Improv't Needed
Audit Work with 'No Opinion'		
21.	Joint Committees - Prosiect Gwyrdd	Consultancy, Certification, Advice and Guidance
22.	Joint Committees - Port Health Authority	
23.	Joint Committees - Glamorgan Archives	
24.	Cardiff Further Education Trust Fund 2021/22	
25.	Education Improvement Grant 2022/23	
26.	Weighbridge software and Associated Controls	
27.	Purchasing and Payments CRSA	Control-Risk
28.	Payroll and HR CRSA	Self-Assessment
29.	National Fraud Initiative	Data matching
Concluded Audits from the Prior Year		
30.	School Asset Management - Thematic (Albany)	Effective
31.	Welsh Government Covid Grants – Assurance	
32.	Performance Management – Economic Development	
33.	Ysgol Bro Edern	
34.	Resources - Health and Safety (cf. 2022/23)	Effective with opportunity for improvement
35.	Harbour Authority	
36.	Cardiff Dogs Home	
37.	Health and safety - Education	
38.	City Deal 2021/22	
39.	Follow up - Cardiff West Community High School	
40.	Waste Management Enforcement	

No.	Assurance Audit Engagement	Audit Opinion
41.	Skip Hire	
42.	Eastern High School	
43.	Ethics and Values	
44.	Pensions and Investments	
45.	Asset Management	
46.	Disposal of Land and Buildings	
47.	Complaints and compliments	
48.	Payroll & HR - In-year Testing 2022/23	
49.	Whistleblowing Processes	Insufficient with Major Improv't Needed
50.	Contract Variations	
51.	Directorate PCI - DSS Compliance	
52.	School Asset Management - St Patrick's Primary School	Unsatisfactory
53.	Central Transport Service	

Further to the table above, the outputs that were not been given an assurance opinion and the reasons for this were as follows:

**Figure 3.** Completed audits without an assurance opinion (at 31 December 2023)

Audit	Comments
Joint Committees - Prosiect Gwyrdd	Work to support completion of Statement of Accounts, 2022/23
Joint Committees - Port Health Authority	
Joint Committees - Glamorgan Archives	
Cardiff Further Education Trust Fund 2021/22	Vouching spend, accounts and applicable grant use
Education Improvement Grant 2022/23	
Weighbridge software and Associated Controls	Consultancy
Purchasing and Payments CRSA	Control-Risk
Payroll and HR CRSA	Self-Assessment
National Fraud Initiative	Data matching

The report status for the year to date is shown in **Appendix A**.

## 2.2 Resources

Through previous progress reports, Committee has been advised of vacant posts held earlier in the year, for which two FTE appointments were made at senior auditor level in July, and two FTE auditor posts were appointed to in October. Committee has also been advised that three CIPFA Trainee postholders commenced in July, with one placed within Internal Audit during the current financial year.

Since their appointments, priority has been given to the development of new staff for their benefit, and for the longer-term benefit of the audit service overall. This was with the knowledge that providing detailed training and support would impact the capacity of the wider team as audit staff across the team have been involved.

All new staff have been supporting the delivery of audit fieldwork and the delivery of the Audit Plan will ramp up during quarter four, with posts now appointed to and with new staff having received initial training and development. Further details are provided in section 2.3 – Audit Plan.

As all operational auditors and the audit assistant record all actual time worked, there is useful management information available for planning, monitoring, and reporting purposes. Timesheet data contained 767 chargeable days in the year to date, against a pro-rata plan of 1,122 days (the pro rata days are calculated as an even quarterly average of available days for the year as a whole and are therefore affected by vacancies held until staff appointments. Staff training and development following appointment is also non-chargeable).

Time is available for audit development purposes, and one Auditor has funding in place to study the Certified Information Systems Auditor (CISA) Qualification with ISACA. To support their development and the delivery of the Audit Plan, it has been arranged for them to shadow and deliver the two ICT audits in the plan alongside a specialist auditor who has been commissioned under contract under the direction of the Audit Manager.

## 2.3 Annual plan

The Committee approved the Audit Plan 2023/24 in its meeting in March 2023 which is contained within Appendix B. Whilst set on an annual basis, the Audit Plan is adaptable and responsive and will be subject to ongoing risk assessment, prioritisation, and review

throughout the year to maximise assurance and management support. In-year changes may be introduced where appropriate, to respond to emerging risks and issues as the year progresses.

Through engagement with senior officers within the Education Directorate, a request was made to add two advisory audits to this year's Audit Plan, on 'schools education technology procurement' and 'school catering controls'. The request has been made by the Operational Manager who has taken on responsibility for these areas after the recent retirement of the Head of Services to Schools and asked for an audit review of the controls in place. These reviews have been agreed by the Audit Manager in accordance with his delegation to approve audit engagements of no more than 10 planned audit days without seeking approval from the Governance and Audit Committee.

Delivery of the Audit Plan 2023/24 is proportionately lower than the pro rata target as at the end of quarter three, for which the reasons primarily relate to vacant posts being held during quarter one, followed by appointments being made during quarter two for which training, and development have been prioritised as outlined in section 2.2. 'Resources'.

At the current stage in the financial year, the Audit Plan has been reviewed and prioritised to support a full audit annual audit opinion, through completing sufficient testing of fundamental systems, ensuring sufficient coverage in respect of planned corporate governance audits areas and an appropriate spread of service level audit work.

The audits being targeted for completion to draft reporting stage in the remainder of the year are contained within the table below. Completion of these audits would achieve a proportion of the Audit Plan completed at 69% for the year overall (against a target at the start of the year of 70%). The level of completion of the Audit Plan by 31 March 2023 will be affected by audit and client staff availability, as well as the complexity of issues that may arise during the audit fieldwork; however, any of the following audits that are not completed to draft report stage by the financial year end will be prioritised for completion in quarter 1 2024/25.

**Figure 4.** Targeted audits for completion during quarter 4.

Assignment	Area of Plan
In-year Testing - Purchasing Payments and Processing In-year Testing - Payroll & HR Main Accounting NNDR Treasury Management	Fundamental Systems
Backup and Data Recovery Cradle to Grave Audit Business Continuity	Corporate Audits
FOLLOW UP - Central Transport Service Event Management (Cardiff Castle) Community Safety Emergency Duty Team Climate Change Risk Management Building Repairs and Maintenance Falconwood Children's Home Direct Payments - Children's and Adults Hubs Street Cleansing Waste Management Overtime	Service Specific Audits
Cathays High school Woodlands High school Thornhill Primary Fairwater Primary Kitchener Primary Ysgol Gyfun Gymraeg Plasmawr Bishop of Llandaff High school	Schools Audits
Cardiff Further Education Trust Fund 2022/23 City Deal 2022/23	Grant / Certification / External Audits
Schools Education Technology Procurement School Catering Controls	Advisory Audits

For the information of the Committee, all audits that were at draft status at the end of 2022/23 are highlighted in 'grey' in order to enable the finalisation of these audits to be tracked, whilst providing a visible separation from the audit engagements contained within the Audit Plan 2023/24.

At all times audits are allocated on the basis that assurance is maximised and that a sufficient spread of coverage will be achieved in order to mitigate any risk to the provision of a full audit opinion on the Council's control environment at the financial year end. Performance measures are shown in section 3.2 'performance'.

#### 2.4 Critical Findings or Emerging Trends (Q3 2023/24)

During quarter three, two draft reports have been issued with audit opinions of 'insufficient with major improvement needed'. Management consideration and discussions will follow before the reports are finalised, at which time the assurance ratings and recommendations will be confirmed. Further details are provided on these audits below, together with details of an advisory review completed on the weighbridge software and associated controls.

An audit of Cyber Security in Schools focused on the arrangements within the Council for the direction and oversight of cyber security across the 128 schools within its boundary. The review considered the strategy that the Council implemented for managing funds provided by the Welsh Government programme for improving the use of digital technology for teaching and learning in schools and the impacts on the maturity of the Authority's cyber security posture. The report has provided an opinion of insufficient with major improvement needed and raises a small number of core governance and system-based recommendations which are designed to provide the basis of a framework for cyber security management and assurance across schools. These recommendations serve as practical building blocks upon which cyber security maturity and assurance can be developed and enhanced.

Arrangements for managing cyber security in schools demonstrate positive aspects, including alignment with the Welsh Government's Education Digital Standards, procurement of devices through a central catalogue maintained by the Government, and well-secured device deployment. However, it was considered that there was a need for clear ownership and defined roles, and responsibilities for cyber security in schools across key stakeholders including the



Council's Education Directorate, central ICT, Governing Bodies and schools. These are considered as essential to protect schools from cyber-attacks which could disrupt the education of learners, cause financial loss through data breaches and reputational damage to the Council and its schools. The audit identified several areas for improvement, including:

- Integrating cyber security into education technology investment strategies
- Enhancing third-party security assurance
- Establishing a structured governance framework with appropriate reporting and assurance
- Developing training, policies, and minimum cyber security standards for schools to comply with.

School Governors should have a critical role in supporting and overseeing the management of cyber security risk in educational settings regardless of whether they are using school IT systems themselves. Hwb have published high level guidelines for school governors with regards to the themes and the questions they should be asking schools, and this information has been signposted in the report to support training and awareness.

An audit of Purchasing Cards reviewed cardholder policies, procedures, controls and oversight, for which an opinion of insufficient with major improvement needed has been provided. It is considered that the general framework for procurement cards is sufficient, but systems were not being appropriately followed based on the sample and testing completed. The pertinent findings from the audit are outlined below.

From the sample selected, there were examples of purchases made which should have been made through other routes, such as business travel, car rental and foreign currency, and a split transaction was also noted to avoid exceeding a card transaction limit. There were a number of cases where cards were not being solely used by the assigned card user listed, but by at least one member of a wider team, which is not allowed in the terms of use. There were also instances where cards had not been cancelled or reassigned when officers were on maternity leave. More generally transactions were not being consistently reviewed, coded and reconciled by the end of each month, for effective and timely monitoring and oversight, and it is felt that consideration should be given to the seniority of officers who can approve transactions. Relevant managers are being made aware of the matters identified through the audit relating to their areas of responsibility, and recommendations have been made for management and corporate oversight and assurance arrangements to be strengthened.

In November, the Committee was advised that an advisory audit review was being arranged to review the weighbridge software and associated controls, following the procurement of a new system. The audit has been completed and, whilst some control improvements are noted since previous audit reviews, the new system purchased did not have some core reporting functionality for which further details are provided below. There has been a positive and prompt response to the matters raised during the audit, and it is essential that the system and management controls are now fully addressed.

The Weighbridge software system records weighbridge activity (waste movements) at Lamby Way and Bessemer Close, and there were several pressures for the recent system upgrade, notably that the existing software was being unsupported.

The service has implemented improvements since previous audit reviews, notably:

- An independent officer has been introduced to visually check and record the contents of all vehicles before entering the weighbridge. The materials recorded are being checked independently to the materials entered by the weighbridge operator.
- The weighbridge operator does not have the ability to amend tickets which record the weight and category of materials after transactions have completed. Any amendments at this stage are now limited to the Weighbridge Supervisor and Weighbridge Data Manager.

Not all required software functionality was available at the point of implementation, and this has affected monitoring and review processes within the service:

- A report on manual entries, which should only be required for operational reasons on an exception basis, has recently been made available. Any use of this functionality requires close monitoring and understanding, which the report will now facilitate.
- The system has not been able to report on amended tickets (materials and weight). At the point of reporting this remains as a priority development request for the software provider. In the meantime, management have agreed for weekly sample checks of tickets processed, through which identified ticket amendments would be reviewed. However, it is recognised that this is a core report that is needed for management monitoring and oversight.

A small number of wider audit comments have been provided to management on the weighbridge, and there are ongoing and regular discussion on system development and controls

with audit and senior officers within waste management, who are in regular engagement with the provider. This will continue until the required system reports are available and in use, and it is intended to include a follow up assurance audit on the weighbridge in the Audit Plan 2024/25.

#### 2.5 Value for Money findings (Q3 2023/24)

An audit of value for money in use of Council vehicles has been recently completed and the findings were contained within the progress report to Governance and Audit Committee in November 2023. The vast majority of audits undertaken by the Internal Audit Team have objectives which cover value for money assurances, from which a general satisfactory level of assurance can be provided for the reporting period. However, within the audits of a lower assurance opinion, there were control gaps which need to be addressed to provide assurance that the objectives of these services are being run with proper attention to a combination of economy, efficiency, and effectiveness.

### **3 AUDIT PERFORMANCE AND ADDED VALUE**

#### 3.1 Added Value

Relationship Manager meetings have continued to be held on a quarterly basis with Directors and their representatives during 2023/24. Particular focus has been given to understanding the priorities and risks within each management team, and the changes to systems or processes planned or underway, in order to direct audit advice and inform the planning of audit engagements.

Feedback from audit clients has been generally positive with 93% satisfaction and 88% of clients scoring all areas of their audit as good or excellent. Details were provided in the July Committee of the reasons why one audit did not receive satisfactory feedback from the audit client. All other clients reported that their audits added value.

In the audit outputs issued to date (as at 31 December 2023), there have been 93 recommendations made, of which 50 have been agreed through a finalised report. All other recommendations are being considered by audit clients through draft audit outputs. These are summarised below:

**Figure 5.** Recommendations raised and agreed.

Rating	Recommendations made	Recommendations agreed	Recommendations being considered
Red	2	0	2
Red / amber	27	12	15
Amber / green	54	34	20
Green	10	4	6
TOTAL	93	50	43

### 3.2 Performance

As outlined in section 2.1 ('Current Activities'), the priorities and approach of the audit team in the year to date were to deliver a combination of management support through consultation and engagement in high-risk areas, and to commence the delivery of assurance engagements from the Audit Plan 2023/24.

The primary reasons why the audit service is operating at a lower capacity during the quarter are outlined in 2.2 ('Resources'). At the outset of the year, a proposed target for delivery of the Audit Plan is set at 70% and this has been integrated into audit planning and performance management processes. The target was considered to be stretching and achievable, for which the primary reasons for slippage arise from vacant posts at the beginning of the year, followed by the prioritisation given to development new staff following their appointment, for their benefit, and for the longer-term benefit of the audit service overall. This was with the knowledge that providing detailed training and support would impact the capacity of the team.

The average number of audit productive days has been notably affected by the training requirements of the new Members of the Team following their appointment. Following their initial training, the performance against this measure should proportionately improve during quarter four.

A number of audits have been finalised from last financial year, as is shown in figure 2, and attention is being given to the timely conclusion of draft audit reports.

Only one draft report has not been issued in draft within four weeks in the year to date, which was in respect of the audit of 'Cyber Security within Schools'. This delay in reporting was

intentional, in order to engage with both the Director of Education and the Chief Digital Officer on the audit findings and the proposed way forward before the report was formally issued.

Governance and Audit Committee Members have taken particular interest in performance against the percentage of audit recommendations implemented within the agreed timescale, which has been below target for a number of years. The target of 80% for 2023/24 represents an ongoing expectation of the high delivery of agreed management actions, and an expected improvement of directorate performance from 2022/23. Performance against this measure has marginally improved in quarter three, after falling in quarter two. The importance of delivering on this target continues to be emphasised with the Senior Management Team.

**Figure 6.** Performance against targets for 2023/24 (to date)

Performance Indicator	2022/23 Outcome	2023/24 Target	Q1 Outcome	Q2 Outcome	Q3 Outcome
The percentage of the Audit Plan completed	52%	70%	12%	24%	34%
The average number of audit productive days per FTE	144	150	28.48	54.21	86.99
The average number of finalised audits per FTE	6.64	8	3.07	4.35	5.75
The percentage of draft audit outputs delivered within four weeks	91%	90%	100%	100%	96.55%
The percentage of audit recommendations implemented within the agreed timescale	67%	80%	80%	71%	73%

### 3.4 Audit Plan Delivery

In addition to monitoring and managing the numbers of audits delivered, audit engagements are allocated in order to ensure that there is a breadth of assurance by the financial year-end, upon which to provide a complete Audit Manager annual opinion.

As outlined in section 2.1 – Current Activities, twenty-nine new audit engagements had been completed as at the end of quarter three 2023/24. The current position for the full Audit Plan 2023/24 is shown in **Appendix B – Audit Plan**.

### 3.5 Recommendations

A summary of the audit recommendations and progress at the reporting date are provided within **Appendix C**. Full recommendation trackers on the recommendations open, and those completed since the last committee, are available for Governance and Audit Committee Members via a SharePoint site for information and reference.

**Figure 7.** Revised recommendation implementation dates and status

Directorate / Audit Category	Number of recommendations with revised dates	Actions now implemented	Actions still open
Fundamental	19	17	2
Corporate	32	21	11
External and grants	12	12	
Adult Services, Housing & Communities	37	37	
Children's Services	26	19	7
Economic Development	48	45	3
Education and Lifelong Learning	93	64	29
Planning Transport and Environment	54	41	13
People and Communities	1	1	
Resources	80	56	24
Governance and Legal Services	10	10	
Waste Management	39	36	3
	451	359	92
Schools	228	185	43
<b>TOTAL</b>	<b>679</b>	<b>544</b>	<b>135</b>

**NB** - It should be noted that the table above represents the position as at 31 December 2023, whereas the recommendation tracker appendices show the detailed position against each recommendation at the closest possible date to each Committee meeting.

## 4. CONCLUSION

### 4.1 Summary

During quarter three 2023/24, the priorities and approach of the audit team were to deliver a combination of management support through consultation and engagement in high-risk areas, and to progress delivery of assurance engagements from the Audit Plan.

Following the appointment to vacant posts, priority has been given to the development of new staff for their benefit, and for the longer-term benefit of the audit service overall. This

was with the knowledge that providing detailed training and support would impact the capacity of the wider team as audit staff across the team have been involved.

At the current stage in the financial year, the Audit Plan has been reviewed and prioritised to support a full audit annual audit opinion, through completing sufficient testing of fundamental systems, ensuring sufficient coverage in respect of planned corporate governance audits areas and an appropriate spread of service level audit work.

The audits being targeted for completion to draft reporting stage in the remainder of the year have been set out in this report. The level of completion of the Audit Plan by 31 March 2023 will be affected by audit and client staff availability, as well as the complexity of issues that may arise during the audit fieldwork; however, any of the targeted audits that are not completed to draft report stage by the financial year end will be prioritised for completion in quarter 1 2024/25.

This page is intentionally left blank



## Report Status (as at 31 December 2023)

Audit Opinion	Audit Area	High Risk Recommendations		Status (If not Final)
		Proposed	Agreed	
Fundamental / High				
Effective	Purchasing Payments and Processing - In-year Testing 2022/23 (c. 2022/23)			Drafts
	Performance Management – People and Communities			Issued
	Performance Management – Resources			
	Insurance			
	School Asset Management - Thematic (Albany) (cf. 2022/23)			
	Welsh Government Covid Grants - Assurance (2021/22) (cf. 2022/23)			
	Performance Management – Economic Development (cf. 2022/23)			
	Performance Management – Adults, Housing & Communities			
	Performance Management – Governance and Legal Services			
	Performance Management – Children’s Services			
	Performance Management – Planning, Transport and Environment			
	Information Governance			
	Taxation			
Effective with opportunity for improvement	Income and Debtors (cf. 2022/23)			Drafts
	Partnership / Arms-length Assurance (cf. 2022/23)			Issued
	Value for money in use of Council Vehicles			
	Resources - Health and Safety (cf. 2022/23)			
	Ethics and Values (cf. 2022/23)			
	Pensions and Investments (cf. 2022/23)			
	Asset Management (cf. 2022/23)			
	Health and safety – Education (cf. 2022/23)			
	Complaints and compliments (cf. 2022/23)			
	Payroll & HR - In-year Testing 2022/23 (c. 2022/23)			
	Performance Management – Education & Lifelong Learning			
	Whistleblowing Processes (cf. 2022/23)			
	Housing Rents			
Insufficient with	Contract Variations (cf. 2022/23)	1	1	

Audit Opinion	Audit Area	High Risk Recommendations		Status (If not Final)
		Proposed	Agreed	
major improvement needed	Directorate PCI - DSS Compliance (cf. 2022/23)	1	1	
	School Asset Management - St Patricks Primary School (cf. 2022/23)	1	1	
	Purchasing Cards	1		
	Cyber Security (Schools) – ICT Managed Technology	1		
Medium				
Effective	Electoral Services			Drafts Issued
	Ysgol Bro Edern (cf. 2022/23)			
Effective with opportunity for improvement	Schools with Surplus Balances – Thematic (cf. 2022/23)			Drafts Issued
	Catering in Opted out schools (cf. 2022/23)			
	Alarm Receiving Centre (cf. 2022/23)			
	Commercial Waste			
	Planning			
	Facilities Management / Building Support			
	Harbour Authority (cf. 2022/23)			
	Cardiff Dogs Home (cf. 2022/23)			
	Follow up - Cardiff West Community High School (cf. 2022/23)			
	Waste Management Enforcement (cf. 2022/23)			
	Skip Hire (cf. 2022/23)			
	Eastern High School (cf. 2022/23)			
	Catering in opted out schools - Mary Immaculate (cf. 2022/23)			
	Catering in opted out schools – Cardiff HS (cf. 2022/23)			
	Catering in opted out schools - Whitchurch HS (cf. 2022/23)			
	Disposal of Land and Buildings (cf. 2022/23)			
	Catering in opted out schools - Greenhill School (cf. 2022/23)			
Youth Offending Service				
	Pest Control			
Unsatisfactory	Central Transport Service (cf. 2022/23)	2	2	
Grants / Accounts / External Bodies				
Effective with Opp' for Improvement	City Deal 2021/22 (cf. 2022.23)			

Audit Opinion	Audit Area	High Risk Recommendations		Status (If not Final)
		Proposed	Agreed	
No assurance opinion given	Joint Committees - Prosiect Gwyrdd	Statement of Accounts Reviews / Certification / Support		
	Joint Committees - Port Health Authority			
	Joint Committees - Glamorgan Archives			
	Education Improvement Grant 2022/23	Vouching spend, accounts and applicable grant use		
	Cardiff Further Education Trust Fund 2021/22			
	Purchasing and Payments CRSA	Control-Risk Self-Assessment		
	Payroll and HR CRSA			
	National Fraud Initiative	Data matching Consultancy		
	Weighbridge software and Associated Controls			

This page is intentionally left blank

Audit Category	Risk	Engagement Type	CIPFA Classification	Original audit plan 2022/23	Original Audit Plan 2023/24	Assignment	Days	Audit Scope	National Issue	Audit Output Status 31.12.2023	Audit Opinion
<b>Fundamental Audits - S151 Assurance</b>											
Purchasing Payments and Processing	High	Assurance	Chargeable	50	50	In-year Testing 2022/23 (c. 2022/23)	0	Purchases and Payments are compliant, authorised, accurate and timely		Draft Issued	Effective
						CRSA	5	Purchases and Payments are compliant, authorised, accurate and timely		Final Issued	No opinion
						In-year Testing	25				
				Purchasing Cards	20						
Payroll & HR				50	50	In-year Testing 2022/23 (c. 2022/23)	0	As below		Draft Issued	Insufficient with Major Improvement Needed
						CRSA	5	Recruitment processes are transparent and robust, leave processes are well governed, only bona fide, authorised and accurate payments are made, with effective prevention, detection and recovery of errors		Final Issued	Effective with Opportunity for Improvement
						In-year Testing	25			Final Issued	No opinion
						Time Recording	20				
Income and Debtors				0	0	Income and Debtors (cf. 2022/23)	0	Operation of appropriate arrangements to record, monitor and recover sundry debts.		Draft Issued	Effective with Opportunity for Improvement
						3	20	Income and Debtors		20	Operation of appropriate arrangements to record, monitor and recover sundry debts.
NNDR				0	20	NNDR	20	Business rate collection and control is working effectively and efficiently			
Treasury Management				0	20	Treasury Management	20	Effective treasury management strategy, governance, risk management and monitoring framework			
Main Accounting				0	20	Main Accounting	20	The main accounting system and processes are well controlled and operating effectively			
Asset Management				0	20	Asset Management	20	Effective recording, monitoring, management and control of physical assets			
Housing Rents	0	10	Housing Rents	10	Effective control processes are in place for managing and recovering housing rents						
Pensions and Investments	0	0	Pensions and Investments (cf. 2022/23)	0	Effective compliance and control	Draft Issued	Effective with Opportunity for Improvement				
Asset Management	0	0	Asset Management (cf. 2022/23)	0	Effective recording, monitoring, management and control of physical assets	Final Issued	Effective with Opportunity for Improvement				
Council Tax	20	0									
HB / LHA/ CTRS	20	0									
<b>Total</b>				<b>143</b>	<b>210</b>		<b>210</b>				
<b>Corporate Audit</b>											
Risk Management	High	Assurance	Chargeable	15	15	Climate Change Risk Management	15	Risk management arrangements are effective and operated consistently			
Contract Audit				40	40	Contract Variations (cf. 2022/23)	0	Effective contract compliance, control and delivery of objectives		Final Issued	Insufficient with Major Improvement Needed
						Cradle to Grave Audit	20	Effective contract compliance, control and delivery of objectives			
						Framework Agreements	20				
Taxation				20	20	Taxation	20	Effective compliance and control.		Draft Issued	Effective
Procurement				20	20	Procurement	20	Effective and compliance commissioning and procurement compliance and control arrangements			
Mileage & subsistence				15	15	Mileage & Subsistence	15	Accurate claiming and authorisation for reasonable expenditure.			
Fleet Management				0	20	Fleet Management	20	Effective governance, risk management and control			
ICT Audit				30	30	Directorate PCI - DSS Compliance (cf. 2022/23)	0	Effective co-ordination, risk management and control		Final Issued	Insufficient with Major Improvement Needed
						Backup and Data Recovery	15	Effective governance, risk management and control			
						Cyber Security (Schools) – ICT Managed Technology	15	Effective governance, risk management and control			
National Fraud Initiative				10	10	National Fraud Initiative	10	Data matching counter-fraud exercise		Draft Issued	Insufficient with Major Improvement Needed
Value for Money studies				30	Assurance	Value for money in use of Council Vehicles	15	Assurance on value for money in use of Council vehicles		Final Issued	No opinion
						Value for money in use of Overtime	15	Value for money in use of overtime		Draft Issued	Effective with Opportunity for Improvement
Stores	10	10	Lamby Way Stores	10	Effective and efficient stores management, and stock / equipment control						
Education - SOP	20	20	Education - SOP	20	Delivery of objectives, with effective compliance and control						
Governance Arrangements	20	20	Governance Arrangements TBC	20	Audit of the application of good corporate governance arrangements						
Programmes and Projects	20	20	Programmes and Projects	20	Effective, clear and consistent project governance arrangements.						
System Development	30	30	Provision for System Development	30	Consultation or assurance services, as relevant.						
Wellbeing of Future Generations	0	20	Wellbeing of Future Generations	20	Effective application of Wellbeing of Future Generations requirements.						
Business Continuity	0	20	Business Continuity	20	Effective business recovery and incident management systems.						
Information governance	0	20	Information Governance	20	Effective mechanisms and systems operated in accordance with the data protection act 2018	Draft Issued	Effective				
Delegation and decision making	20	20	Delegation and decision making	20	Effective application of delegated authority and decision making						
Ethics and values	20	0	Ethics and Values (cf. 2022/23)	0	Policy and process alignment to principles of best practice ethics and values	Final Issued	Effective with Opportunity for Improvement				
Ethics and values - Whistleblowing Processes	0	0	Whistleblowing Processes (cf. 2022/23)	0	Whistleblowing processes are compliant and effective	Final Issued	Effective with Opportunity for Improvement				
Welsh Government Covid Grants	20	0	Welsh Government Covid Grants - Assurance (cf. 2022/23)	0	Sample check of effective compliance and control in administering WG Grants	Final Issued	Effective				
Complaints and Compliments	20	0	Complaints and Compliments (cf. 2022/23)	0	Effective arrangements and systems in place for handling complaints & compliments	Final Issued	Effective with Opportunity for Improvement				
Partnership / Arms-length Assurance	20	0	Partnership / Arms-length Assurance (cf. 2022/23)	0	Effective governance, risk management and control arrangements	Draft Issued	Effective with Opportunity for Improvement				
Health and safety	5	0									
Safeguarding	4	0									
Welsh Government Covid Grants - Assurance	20	0									
<b>Total</b>				<b>409</b>	<b>380</b>		<b>380</b>				
<b>Service Specific Audit</b>											
Service / Process Consultancy	High	Consultancy	Chargeable	40	30	Provision for Service / Process Consultancy	30	Consultancy support across the Council, as appropriate		Work Completed	No opinion
Resources	High	Assurance		60	40	Resources - Health and Safety (cf. 2021/22)	0	Directorate health and safety compliance and risk management.		Final Issued	Effective with Opportunity for Improvement
						Performance Management	15	Performance management arrangements are effective, and operated consistently.		Draft Issued	Effective
	Medium	Central Transport Service (cf. 2022/23)				0	Delivery of service objectives with effective compliance and control	Final Issued		Unsatisfactory	
		Alarm Receiving Centre (cf. 2022/23)				0		Draft Issued		Effective with Opportunity for Improvement	
		FOLLOW UP - Central Transport Service				10	Delivery of service objectives with effective compliance and control				
		Insurance				15					
Governance and Legal Services	High	Assurance		45	40	Performance Management	10	Performance management arrangements are effective, and operated consistently.		Draft Issued	Effective
						Electoral Services	20	Delivery of service objectives with effective compliance and control		Draft Issued	Effective
						Land Charges	10			Draft Issued	Effective
People and Communities	High	Assurance		40	30	Performance Management	15	Performance management arrangements are effective, and operated consistently.		Draft Issued	Effective
						Community Safety	15	Assurance on compliance with statutory requirements			
Adults, Housing & Communities	High	Assurance		154	125	Performance Management	15	Performance management arrangements are effective, and operated consistently.		Final Issued	Effective

	Medium					Hubs	10	Assurance on payroll, asset management, information governance, payment and income systems			
						Mental Health Day Services	15	Delivery of service objectives with effective compliance and control			
						Residential Care	15				
						Emergency Duty Team	15				
						Allocations, lettings and voids	20				
						Home Care	15				
						Direct Payments - Children's and Adults	20				
Children's Services	High	Assurance		40	40	Performance Management	15	Performance management arrangements are effective, and operated consistently.		Draft Issued	Effective
	Medium					Youth Offending Service	15	Delivery of service objectives with effective compliance and control		Draft Issued	Effective with Opportunity for Improvement
						Falconwood Children's Home	10				
Economic Development	High	Assurance		100	35	Statutory Compliance	8	Assurance on statutory compliance systems and controls			
						Building Repairs and Maintenance	15	Assurance on asset and financial management in the council and school non-domestic estate			
	Medium					Performance Management (cf. 2022/23)	0	Delivery of service objectives with effective compliance and control		Final Issued	Effective
						Harbour Authority (cf. 2022/23)	0			Final Issued	Effective with Opportunity for Improvement
						Disposal of Land and Buildings (cf. 2022/23)	0			Final Issued	Effective with Opportunity for Improvement
						Cardiff Dogs Home (cf. 2022/23)	0			Final Issued	Effective with Opportunity for Improvement
						Event Management (Cardiff Castle)	7	Delivery of service objectives with effective compliance and control			
						Pest Control	5			Draft Issued	Effective with Opportunity for Improvement
						Commercial Waste	5			Draft Issued	Effective with Opportunity for Improvement
						Facilities Management (Building Support)	10			Draft Issued	Effective with Opportunity for Improvement
Economic Development (Waste Management)				67	30	Waste Management Enforcement (cf. 2022/23)	0			Final Issued	Effective with Opportunity for Improvement
						Skip Hire (cf. 2022/23)	0			Final Issued	Effective with Opportunity for Improvement
						Waste Management Overtime	15				
						Street Cleansing	15				
Education and Lifelong Learning	High	Assurance		182	150	School Asset Management - Albany Primary School (cf. 2022/23)	0	Schools asset management compliance and control.		Final Issued	Effective
						School Asset Management - St Patricks Primary School (cf. 2022/23)	0	Schools asset management compliance and control.		Final Issued	Insufficient with Major Improvement Needed
						Health and Safety (cf. 2022/23)	0	Directorate health and safety compliance and risk management.		Final Issued	Effective with Opportunity for Improvement
	Medium					Performance Management	15	Performance management arrangements are effective, and operated consistently.		Draft Issued	Effective with Opportunity for Improvement
						Ysgol Bro Edern (cf. 2022/23)	0	Audit of systems of governance and internal control within individual school		Final Issued	Effective
						Eastern High School (cf. 2022/23)	0	Audit of systems of governance and internal control within individual school		Final Issued	Effective with Opportunity for Improvement
						Schools with Surplus Balances - Thematic (cf. 2022/23)	0	Effective compliance and control		Draft Issued	Effective with Opportunity for Improvement
						Catering in Opted out schools (cf. 2022/23) - Corporate Report	0			Draft Issued	Effective with Opportunity for Improvement
						Catering in opted out schools - Mary Immaculate (cf. 2022/23)	0			Final Issued	Effective with Opportunity for Improvement
						Catering in opted out schools - Cardiff HS (cf. 2022/23)	0			Final Issued	Effective with Opportunity for Improvement
						Catering in opted out schools - Whitchurch HS (cf. 2022/23)	0			Final Issued	Effective with Opportunity for Improvement
						Catering in opted out schools - Greenhill School (cf. 2022/23)	0			Final Issued	Effective with Opportunity for Improvement
						FOLLOW UP - Cardiff West Community High School (cf. 2022/23)	0			Final Issued	Effective with Opportunity for Improvement
						School Admissions	15	Effective and well governed arrangements for school admissions			
						Secondary school audits * 4	30	Audits of systems of governance and internal control within individual schools			
						Primary school audits * 3	15				
						Schools VAT Assurance	15	Effective compliance and control			
						Cashless catering in secondary schools	15				
						Governor Services	15				
						Schools Information Management	20				
						Youth Service	10				
Planning, Transportation and Environment	High	Assurance		55	45	Performance Management	15	Performance management arrangements are effective, and operated consistently.		Final Issued	Effective
	Medium					Highways Maintenance	15				
						Planning	15			Draft Issued	Effective with Opportunity for Improvement
<b>Total</b>				<b>783</b>	<b>565</b>		<b>580</b>				
<b>External</b>				<b>Original audit plan 2022/23</b>	<b>Original audit plan 2023/24</b>	<b>Assignment</b>	<b>Days</b>				
External clients	High	Assurance	Chargeable	25	35	City Deal 2021/22 (cf. 2022/23)	0	Scope as per rolling SLA	y	Final Issued	Effective with Opportunity for Improvement
						City Deal 2022/23	10	Scope as per rolling SLA	y		
	Low	Certification				Cardiff Further Education Trust Fund 2021/22	0			Final Issued	No opinion
						Cardiff Further Education Trust Fund 2022/23 - tbc	2	Grant certification / statement of accounts work			
						Norwegian Church Preservation Trust 2022/23 - tbc	2				
						Joint Committees	6			Final Issued	No opinion
						Education Improvement Grant 2022/23 - tbc	15			Final Issued	No opinion
<b>Total</b>				<b>25</b>	<b>35</b>		<b>35</b>				
<b>Contingencies</b>				<b>Original audit plan 2022/23</b>	<b>Original audit plan 2023/24</b>	<b>Assignment</b>	<b>Days</b>				
General Audit	TBC	TBC	Chargeable	10	70	General Audit (provision for carried forward audits / other work)	55	General Audit (provision for carried forward audits / other work)			
<b>Total</b>				<b>10</b>	<b>70</b>		<b>55</b>				
<b>Management</b>				<b>Original audit plan 2022/23</b>	<b>Original audit plan 2023/24</b>	<b>Assignment</b>	<b>Days</b>				
Corporate work – Audit Committee, Audit Wales etc.	Medium	Management	Chargeable	50	50	Corporate work – Audit Committee, Audit Wales etc.	50	Internal Audit management, planning, guidance and support activities.			
Assurance mapping		Management	Chargeable	15	20	Assurance mapping	20				
CRSA development		Management	Chargeable	10	10	CRSA development	10				
Process development		Management	Chargeable	15	15	Process development	15				
Work for Audit Manager		Management	Chargeable	15	30	Work for Audit Manager	30				
Planning, monitoring & reporting		Management	Chargeable	30	30	Planning, monitoring & reporting	30				
Review of financial rules etc.		Management	Chargeable	40	60	Review of financial rules etc.	60				
General advice and guidance		Management	Chargeable	10	20	General advice and guidance	20				
<b>Total</b>				<b>185</b>	<b>235</b>		<b>235</b>				
<b>Total chargeable days</b>				<b>1,555</b>	<b>1,495</b>		<b>1,495</b>				

Directorate / Area	'open recommendations' - by audit assurance rating								'open recommendation' by status		
	No. of Audits	No. of Red Recs	No. of Red/ Amber Recs	No. of Recs Effective	No. of Recs Effective with Opportunity for Improvement	No. of Recs Insufficient with major improvement needed	No. of Recs Unsatisfactory	No. of Recs N/A	No. of Recs with Amended Action Date	No. of Recs where action date has passed	Current target date not yet due
Adults Social Services, Communities & Housing	1		2		2						2
Children's Services	4	2	3			4		1	5		5
Corporate Governance (Resources)	3		3		3				1	1	2
Corporate Governance (Governance & Legal Services)	1		2		2						2
Economic Development	5	2	6		5	3			5	2	6
Education & Lifelong Learning	7	2	10		7	5			11		12
Education & Lifelong Learning - Schools	15		27		26	1			24	19	8
External and Grants (Resources)											
Fundamental (Resources)	1		1		1				1		1
Other Assurance (Resources)	1		2			2			2		2
People and Communities											
Planning, Transport & Environment	8		11		7	2		2	11	1	10
Resources	4	3	15		2	6	10		16	6	12
Social Services - General											
<b>TOTALS</b>	<b>50</b>	<b>9</b>	<b>82</b>	<b>0</b>	<b>55</b>	<b>23</b>	<b>10</b>	<b>3</b>	<b>76</b>	<b>29</b>	<b>62</b>

1 - N/A action related to instance where Directorate was sampled as part of a wider corporate report, and an opinion was not provided at a directorate level

1 - overdue action, where an update has been requested

1 - overdue action, where an update is pending

1 - overdue action, where an update has been requested

6 - overdue actions, where Audit is liaising with the school

7 - overdue actions, where an update has been requested

2 - overdue actions, where evidence has been requested

4 - overdue action, where action will be carried forward to follow-up audit

1 - overdue action, where an update has been requested

2 - N/A actions related to instance where Directorate was sampled as part of a wider corporate report, and an opinion was not provided at a directorate level.

4 - overdue actions, where an update has been requested

2 - overdue actions where evidence has been requested

This page is intentionally left blank





# Resources Directorate Internal Audit Section

## Investigation Team Progress Report

(as at 31 December 2023)

2023/24

### Planning & Resources

There are four hundred and fifty-two planned chargeable days available for the year based on current resources, indicatively split between strategic (72 days) and operational activities (380 days), as summarised below:

Strategic	Policy and procedure review / planning	25	Days
	Fraud awareness / reporting	23	
	Training development / delivery	10	
	Intelligence sharing / working groups / police liaison	8	
	National Fraud Initiative	6	
Operational	Council Tax Liability (CTL)	130	Days
	Council Tax Reduction (CTR)	80	
	Other fraud (Ad hoc and contingency)	60	
	Employee misconduct (disciplinary investigations)	55	
	Tenancy fraud	45	
	Grants	5	
	Advice and guidance	5	

NB – Audit Manager time is not included within the above apportionment.

### Activities

In the financial year to 31 December 2023, the team have applied 358 days as follows:



### Operational Activity Days

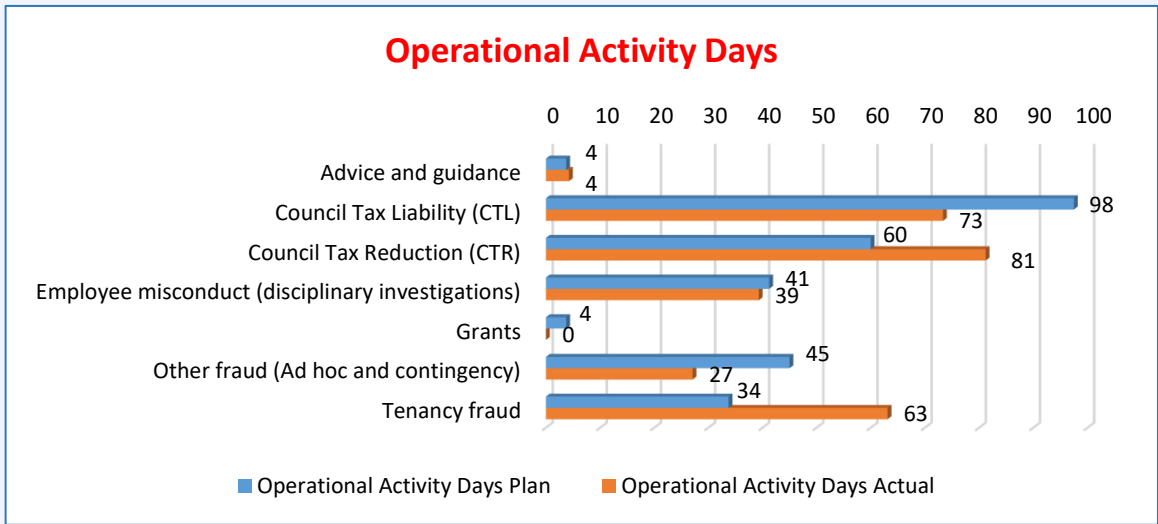

### Strategy, Policies, Training and Awareness

**Counter-Fraud, Bribery and Corruption Strategy and counter-fraud operational document updates** were approved by Cabinet in [December](#), which followed consideration by the Governance and Audit Committee in November.

**Mandatory Fraud Awareness training** continues to be delivered. More than six thousand staff and school governors have completed the eLearning or attended a face-to-face session. Face-to-Face workshops have been arranged for the management of staff who do not use PCs for their work so that they can disseminate the Training. New eLearning has been developed and is planned to be rolled out in the forthcoming financial year.

**Anti-Money Laundering eLearning** is in place to reinforce the requirements of the Council’s Anti-Money Laundering Policy. The Money Laundering Reporting Officer (MLRO) is a senior officer in the Internal Audit Section, for reporting, advice and guidance needs.

### Cases Identified for Investigation

118 cases have been identified for investigation so far this year, compared to 82 for the same period last year: Insurance data is not currently available, the position for insurance cases will next be reported as part of the next Committee update. At this time the outcomes of proactive blue badge work will also be reported.

### Cases identified for Investigation April to December 2023

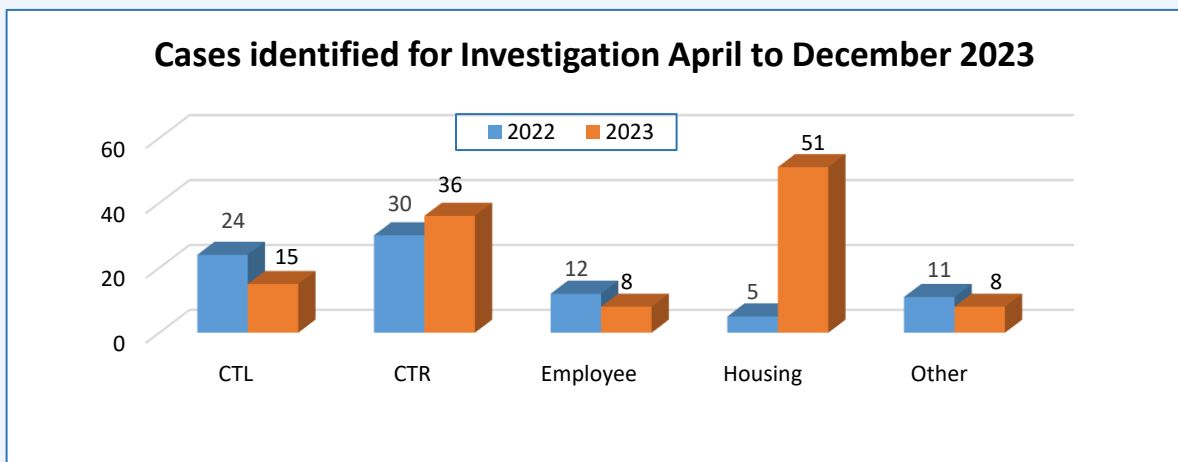

The cases designated as other this year relate to inappropriate subletting of a Council facility, counterfeit pay and display tickets, False representation, Falsification of records, Business Grants and Planning, Cheque fraud, Mandate fraud, Procurement card fraud.

### Ongoing Cases

There are currently 55 investigations ongoing, compared to 43, for the same period last year:

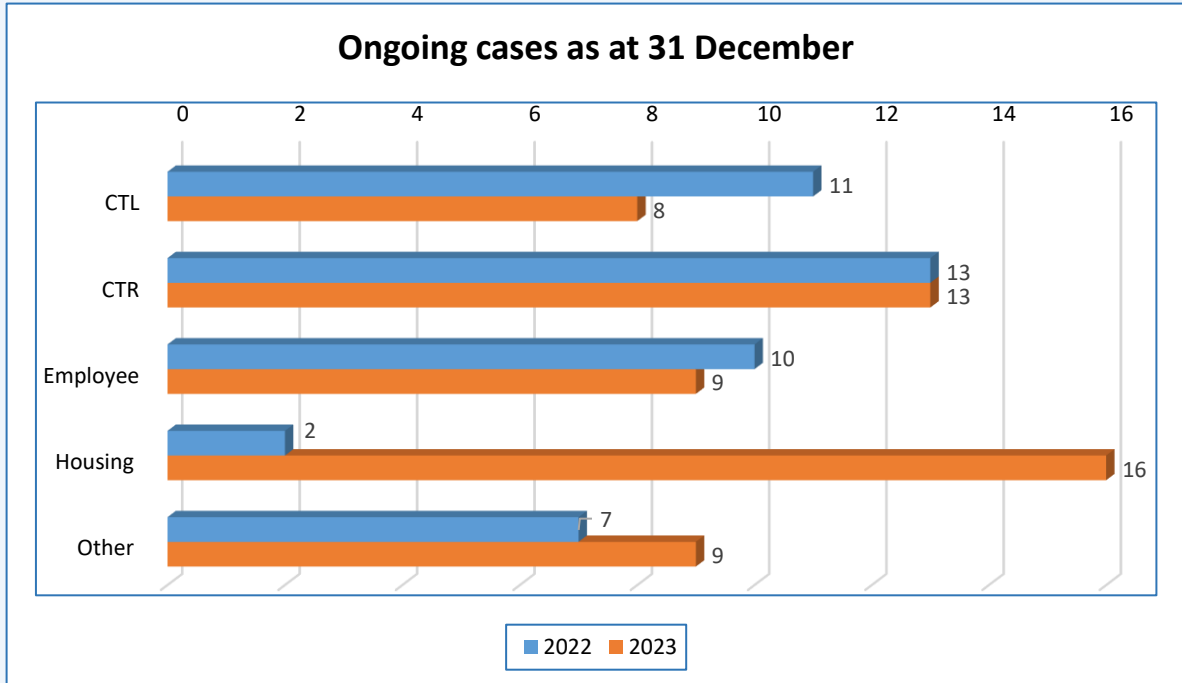

### Concluded Cases

118 investigations have concluded so far this year, compared to 100 over the same period last year:

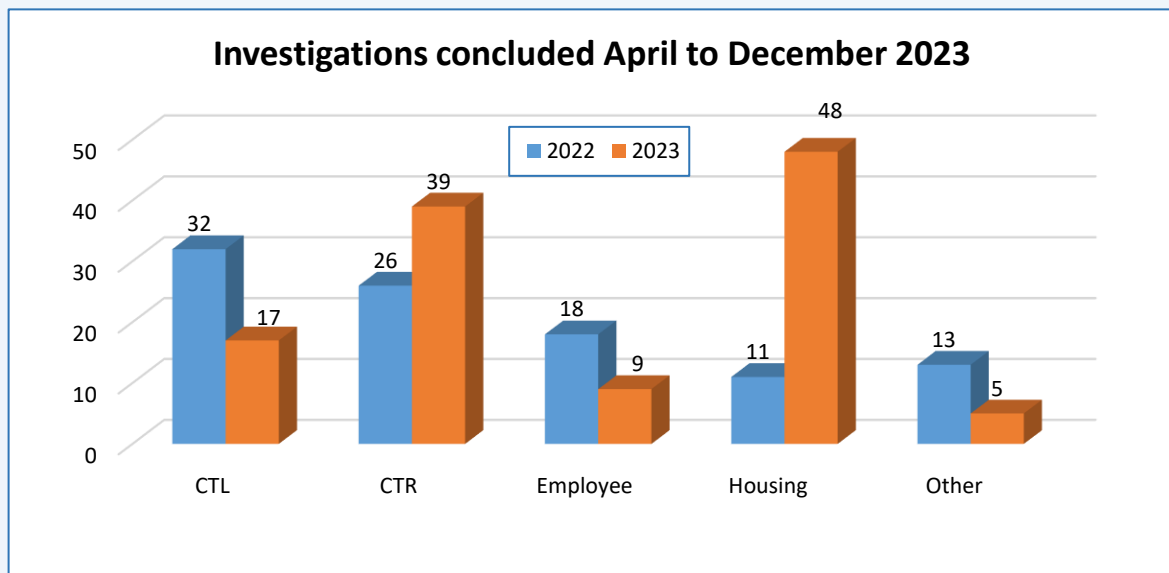

### Financial Value

£523,888 has been attributed to concluded cases in the 2023/24 year to date, compared to £52,441 for the same period last year:

### Value of concluded cases April to December 2023

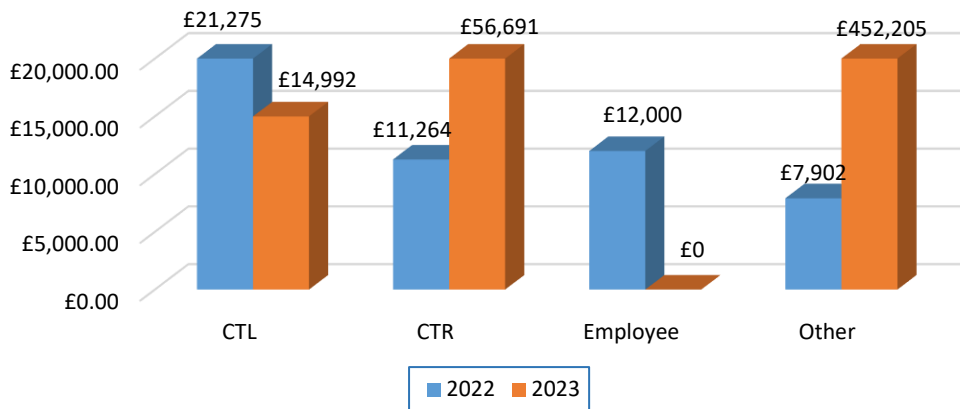

- Council Tax Liability investigations typically relate to cases of false information provided to receive a discount, or a failure to declare the occupation of a second adult, when in receipt of a single person discount.
- Council Tax Reduction investigations typically relate to those on low income, in receipt of a discount, failing to declare their income properly.
- The primary case designated as other relates to the matter that was concluded at Swansea Crown Court Thursday 9 November 2023 and subject to a detailed briefing as part of agenda item 14 Governance and Audit Committee 28 November 2023. The amount attributed to this fraud is £417,000. Details reported by the CPS are contained in the following [Link](#)

#### National Fraud Initiative (NFI) - Overview

In addition to investigating referred cases, the team also undertakes various proactive exercises including participating in data matching exercises run by the Public Sector Fraud Authority and Audit Wales.

The National Fraud Initiative (NFI) matches data for the prevention and detection of fraud, by comparing sets of data electronically, such as the payroll or benefit records to other records held by the same or another body. This data is usually comprised of personal information, and matching identifies inconsistencies that require further investigation and allows potentially fraudulent claims and payments to be identified. These exercises generate a substantial volume of matches, and a risk-based approach is taken to prioritise where resources are targeted. The Investigation Team is currently liaising with Council Tax and Housing to assist with the progression of the matches generated for review.

#### Annual Exercise - Council Tax and Electoral Register

Each year the Corporate Fraud Investigation Team submit council tax single person discount and electoral register data to help find where people are receiving the discount, but are not the only countable adult at their residence.

The next upload is scheduled for 18 January 2024 and matches should be generated that day. The last annual exercise generated matches for Cardiff Council in December 2022, and the review was led by Revenue’s with support from Internal Audit. A targeted review was undertaken, 511 matches were processed, 221 errors were identified and as a result of recalculating council tax liability, £161,121.03 was attributed to these adjusted matches.

**GOVERNANCE & AUDIT COMMITTEE: 23 JANUARY 2024**

---

**DRAFT INTERNAL AUDIT CHARTER AND DRAFT AUDIT PLAN 2024/25****REPORT OF THE AUDIT MANAGER****AGENDA ITEM: 6.2**

---

**Reason for the Report**

1. The Terms of Reference for the Governance and Audit Committee sets out its responsibility:
  - To approve the Internal Audit Charter.
  - To approve the risk-based Internal Audit Plan, containing internal audit's resource requirements, the approach to using other sources of assurances and any work required to place reliance upon those other sources.
2. The Governance and Audit Committee has a responsibility to review its Terms of Reference annually.
3. This report has been prepared to provide Governance and Audit Committee Members with the Draft Internal Audit Charter for 2024/25 and appendices, including a draft Committee Terms of Reference. The report also provides the Draft Summary Audit Plan for 2024/25.

**Background**

4. At the commencement of each financial year, consideration is given to updating key documents which form part of the Internal Audit function. The draft documents are submitted to Governance and Audit Committee at the January meeting to enable members of the Committee to consider and feed in comments which will support the development of final documents to be approved on 26 March 2024 in respect of the new financial year.
5. Under the Public Sector Internal Audit Standards (PSIAS (standard 1110 – organisational independence)), the Governance and Audit Committee is required to approve the Internal Audit Charter and the risk based Internal Audit Plan. These documents are attached for 2024/25 in draft form, with the audit plan presented at a summary level of detail prior to the detailed review and population of audit engagements in quarter four 2023/24. Accompanying the Charter is a draft version of the proposed Committee Terms of Reference for 2024/25, as contained within Appendix D of the Audit Charter.
6. There are only minor updates proposed to the Draft Audit Charter 2024/25, although Committee is advised that a more detailed update will be required for 2025/26. As Committee is advised in agenda item 6.1, the Institute of Internal Auditors (IIA) has

published new Global Internal Audit Standards ([GIAS](#)) which will take effect during 2025. The PSIAS will be aligned to the GIAS to apply to internal auditing of public sector bodies in accordance with this timetable, and the Audit Charter will be aligned accordingly.

## Issues

### Audit Charter

7. The Draft Internal Audit Charter set out in **Annex 1** is a formal document which establishes the Internal Audit Service's position within the organisation, the Audit Manager's functional reporting relationship with the Governance and Audit Committee, authorises access to records, personnel, physical properties relevant to the performance of engagements, and defines the scope of internal audit activities. Governance and Audit Committee formally approved the Internal Audit Charter 2023/24 on 21 March 2023.
8. The Draft Audit Charter 2024/25 has been reviewed and updated. The areas in the Draft Audit Charter that have been adjusted are marked up in bold red font. Contained within the Draft Internal Audit Charter are six appendices, which detail the parameters within which Internal Audit and the Governance and Audit Committee operate.
9. Appendix A sets out the Code of Ethics for Internal Auditors and is focussed on the four key principles of Integrity, Objectivity, Confidentiality and Competence. This appendix is formally used in the quality assurance process as part of each audit, and as part of ongoing performance reviews.
10. Appendix B sets out the Core Principles which taken as a whole, articulate internal audit effectiveness. These Core Principles underpin the Mission of the Internal Audit service *'To enhance and protect organisational value by providing risk based and objective assurance, advice and insight'* in recognition of best practice from the IIA.
11. Appendix C sets out the staffing resources allocated to the Internal Audit function as well as outlining the reporting lines between the Audit Manager, the Section 151 Officer and the Governance and Audit Committee. This section also outlines the skill base of the team and the commitment to developing staff further through Audit or Investigation qualifications.
12. Appendix D suggests the Terms of Reference for the Governance and Audit Committee 2024/25, which is unchanged from last year and reflects both the best practice CIPFA guidance, and Welsh Government statutory guidance.
13. Appendix E sets out the Quality Assurance and Improvement Programme (standard 1300), which is designed to enable an evaluation of the Internal Audit section's conformance with the Standards and an evaluation of whether internal auditors apply the Code of Ethics. The programme also assesses the efficiency and effectiveness of the internal audit activity and is used to identify and deliver opportunities for improvement. The QAIP is built around a performance management approach which involves 'setting expectations', 'reviewing performance', and 'reporting performance' at individual auditor and team levels.
14. Appendix F contains the Audit Protocol, which represents an outline of the audit process from planning to reporting.

## Audit Plan, 2024/25

15. Contained within both the Draft Internal Audit Charter and the Terms of Reference are sections outlining the submission of a risk-based audit plan to be approved by Committee. **Annex 2** contains the preliminary draft plan for 2024/25, which will be developed into further detail over the financial quarter to be submitted for approval by Governance and Audit Committee on 26 March 2024.
16. The draft Audit Plan for 2024/25 is based on a team of 8.96 operational auditors overseen by the Audit Manager, supported by a CIPFA Trainee placed within the team and an Audit Assistant. There are 1.14 full time equivalent (FTE) more operational auditors available to next year's plan than the current financial year following the filling of vacant posts. For prudence, whilst it is intended to place a CIPFA Trainee in the team throughout the year, their resource is not built into the Plan. Committee will note from audit progress updates that when there have been vacant posts some audit services have been commissioned. If planned resources are available throughout the year, it is intended to deliver all audit work in-house during 2024/25.
17. The number of available operational audit days has increased (from 1495 to 1648) since last year, largely due to the increase in headcount following appointments. The main changes to time allocations at the current time since last year are as follows:
  - A slightly lower proportion of time is being allocated to audits of fundamental systems, this follows a base-line approach to auditing such systems every other year, with the exception of creditor payments and processing, payroll and HR systems which are subject to annual audit.
  - A slightly lower proportion of time is being allocated to corporate audit areas, which has received a good level of good recent coverage, and these areas have been considered to be generally well governed.
  - An increase in the time allocated to service specific audits to enable a greater coverage of directorate-level assurance.
18. The Investigation Team Plan is based on 2.42 FTEs. The available resource continues to reflect the ongoing wishes from an investigator to work 34 hour per week (3 hours less than their substantive post). Planning adjustments have been made in respect of non-chargeable time on a consistent basis to the Audit Team.
19. Members will note that the Audit Manager has not been included in the head count of FTE for either team, as this work focusses on strategy, and overseeing the quality, delivery and output across both audit and investigations teams.
20. The draft Audit Plan has been prepared at a summary-level following consideration of a risk-based methodology. The detailed components of the audit planning approach take place throughout quarter four, and will result in the full risk-based audit plan for 2024/25. The approach is designed to be risk based and co-ordinated in application of an assurance mapping exercise based on the IIAs "three lines model".
21. The audit planning process involves the application of three basic review principles as follows:
  - (a) **Informed Inherent Risk** - The starting point is the development of an inherent audit need / risk score as a product of the nature of the potential audit area, and the results of Senior Management Assurance Statement (SMAS) responses from Directors.

- Audit category - There are three broad audit categories which are audited with an inherent frequency in the following priority order from highest to lowest (1) Fundamental systems, (2) Governance functions (e.g., Health and Safety, Performance Management etc.) and (3) Operational audits, such as a school or standard system audit.
- SMAS submissions - The Directorate self-assessments of maturity in a number of core areas of governance, risk management and internal control are considered and used to moderate the inherent prioritisation of audit engagements.

(b) **Coordination and Reliance** - After considering the inherent need for an audit, further sources of assurance and indicators of risk are accounted for, such as:

- Information on risk registers
- Planned and programmed projects, scrutiny and management activities
- Existing levels of Internal Audit assurance, and
- Planned and actual work and findings from wider audit, regulatory and consultancy activities.

(c) **Extensive and Appropriate Audit Coverage** - In consideration of the above two stages, audits will be programmed and typically delivered through a combination of Control Risk Self-Assessment (CRSA), thematic and full audit engagements. The above two stages are in the process of development through relationship management and audit link officer mechanisms in directorates.

22. Section 2010 of the PSIAS specifies that the risk-based plan takes into account the organisation's assurance framework and that the work of Internal Audit addresses both local and national issues. This is achieved through the approach as summarised above, with the assurance available from both within and outside the Council assessed to enable informed decisions regarding the audits to be undertaken in 2024/25. The Governance and Audit Committee will be aware that the Audit Plan is responsive to emerging risks and issues as they arise during the year, and these changes are brought to the Governance and Audit Committee as they arise.

23. The "three lines model" is an important part of the Council's internal control environment. Senior managers, as the first line of defence, have a joint and individual responsibility for risk management, governance and the control environment within their directorate; they use their SMAS as a primary disclosure of their delivery of the management controls and report and disclose on the management of their risks and performance. The second line of defence consists of the arrangements in place to monitor and support internal governance through functions which develop, embed and monitor policies and strategies, such as Risk Management, ICT, Information Governance and Health and Safety functions.

24. As the third line of defence, Internal Audit accounts for the assurance of the first two lines of defence together with external audit and regulatory sources of assurance and indicators of risk (e.g., Audit Wales and Estyn work), in developing a risk-based audit plan. The Summary Plan, as set out in Annex 2, will be fully developed during quarter 4 and supported by an assurance map to recognise and account for the respective internal and external sources of assurance and allocate audit resources to enable the Audit Manager to provide a comprehensive opinion on the overall Council control environment.

25. It is proposed to undertake fundamental audits in 2024/25 in relation to purchasing payments and processing, payroll and HR, council tax, housing benefits / local housing allowance / council tax reduction scheme, income and debtors and asset management.



However, if there are any major system or operational changes during the year in systems that are not included in the plan, an audit of that system will be added to the Audit Plan (and this change reported to a meeting of this Committee).

26. Thematic audits have been undertaken across all directorates in recent years. At the current stage of audit planning no further thematic audits are proposed for 2024/25, and if this continues to be the position once assurance mapping activities have been completed, most of the proposed time allocated to service specific audits would be preserved for individual directorate systems and establishments.

### **Legal Implications**

27. The work of the Governance and Audit Committee must reflect its statutory functions under Part 6, Chapter 2 of the Local Government (Wales) Measure 2011, as amended by Part 6 of the Local Government and Elections (Wales) Act 2021. In discharging its functions, the Committee must have regard to statutory guidance issued by the Welsh Ministers and other relevant guidance, in particular, that issued by the Chartered Institute of Public Finance and Accountancy (CIPFA).
28. The Committee's terms of reference for 2024/25 will be reported for approval at the Annual Council meeting in May 2024.
29. There are no other direct legal implications arising from the recommendations of this report.

### **Financial Implications**

30. There are no financial implications arising from this proposal.

### **Recommendations**

1. To consider and provide comments on the Draft Internal Audit Charter and the accompanying appendices including the draft Terms of Reference for the Governance and Audit Committee for 2024/25, at the current stage of development.
2. To consider and provide comments on the direction of the draft 2024/25 Internal Audit Plan.

**CHRIS PYKE**  
**AUDIT MANAGER**

The following are attached:

**Annex 1:** Draft Internal Audit Charter 2024/25

**Annex 2:** Draft Summary Audit Plan 2024/25

This page is intentionally left blank



CORPORATE RESOURCES  
INTERNAL AUDIT SECTION

Cardiff Council

# INTERNAL AUDIT CHARTER 2024/25 3/24

## Mission Statement

*To enhance and protect organisational value by providing risk based and objective assurance, advice and insight*



## CONTENTS

<b>Internal Audit Charter</b>	<b>1</b>
• Definition, Objective and Scope of Internal Audit	1
• Role and Professionalism	1
• Authority	1
• Organisation	2
• Independence and Objectivity	2
• Responsibility	3
• Internal Audit Plan	4
• Reporting and Monitoring	4
• Quality Assurance and Improvement Programme - QAIP	5
<u>Appendix A:</u> Code of Ethics	6
<u>Appendix B:</u> Core Principles	10
<u>Appendix C:</u> Audit Activity & Resources	11
<u>Appendix D:</u> Governance and Audit Committee Terms of Reference	12
<u>Appendix E:</u> Quality Assurance and Improvement Programme	17
<u>Appendix F:</u> Audit Protocol	20

## **INTERNAL AUDIT CHARTER**

### **Definition, Objective and Scope of Internal Audit**

1. Internal Audit is an independent and objective assurance and consulting activity that is guided by its mission to enhance and protect organisational value by providing risk based and objective assurance, advice and insight.
2. It assists Cardiff Council in accomplishing its objectives by bringing a systematic and disciplined approach to evaluate and improve the effectiveness of the organisation's full control environment in respect of risk management, control and governance processes.

### **Role and Professionalism**

3. The internal audit activity is established by the Governance and Audit Committee. The internal audit activity's responsibilities are defined by the Governance and Audit Committee as part of their oversight role.
4. A professional, independent and objective Internal Audit service is one of the key elements of good governance in Local Government. Cardiff Council's Internal Audit Section seeks to be compliant with the Public Sector Internal Audit Standards and the Local Government Application Note (LGAN), which forms a foundation for an effective Internal Audit service and encompasses the mandatory elements of the Institute of Internal Auditors (IIA) International Professional Practices Framework (IPPF). Through compliance with these standards, all members of the section adhere to the Code of Ethics stipulated within the Standards. This mandatory guidance constitutes principles of the fundamental requirements for the professional practice of internal auditing and for evaluating the effectiveness of the internal audit activity's performance.
5. The Code of Ethics is set out in further detail in Appendix A and works in alignment with the Council's code of professional conduct. The internal audit activity will adhere to Cardiff Council's relevant policies and procedures, and the internal audit activity's protocol. The Core Principles through which the Internal Audit service is delivered are included in Appendix B which, taken as a whole, articulate internal audit effectiveness.

### **Authority**

6. The internal audit activity with strict accountability for confidentiality and safeguarding records and information, is authorised full, free, and unrestricted access to any and all of the organisation's records, physical properties, and personnel pertinent to carrying out an engagement. All employees are

required to assist the internal audit activity in fulfilling its roles and responsibilities. The internal audit activity will also have free and unrestricted access to the Governance and Audit Committee.

## **Organisation**

7. The Audit Manager will report functionally to the Governance and Audit Committee and administratively to the Head of Finance (Deputy Section 151 Officer).
8. The Governance and Audit Committee will receive and consider reports regarding the performance evaluation of the Internal Audit function.
9. The Governance and Audit Committee will approve the internal Audit Charter, the risk based internal audit plan and receive communications from the Audit Manager on the internal audit activity's performance relative to its plan and other matters. The Audit Manager is delegated the authority to make in-year changes to the internal audit plan and approve audit engagements of no more than 10 planned audit days without seeking approval from the Governance and Audit Committee. The Audit Manager will use the audit resources available to deliver the audit plan and buy-in additional resources as required.
10. Management will notify the Audit Manager immediately, in accordance with the Council's Financial Procedure Rules and related policies, of suspected breach, theft or loss of Council assets, and any suspected or detected fraud, corruption or impropriety.
11. The resources allocated to the Internal Audit activity are outlined in Appendix C, in conjunction with the reporting arrangements.

## **Independence and Objectivity**

12. The internal audit activity will remain free from interference by any element in the organisation including matters of audit selection, scope, procedures, frequency, timing, or report content, to permit maintenance of a necessary, independent, and objective mental attitude.
13. The Audit Manager oversees the Investigation and Internal Audit teams. In any case where the Audit Manager has, or is expected to have, roles and / or responsibilities that fall outside of internal auditing, safeguards will be established to maintain independence and objectivity.
14. Internal auditors will have no direct operational responsibility or authority over any of the activities audited. Accordingly, they will not implement internal controls, develop procedures, install systems, prepare records or engage in any other activity that may impair internal auditor's judgement.

15. Internal auditors must exhibit the highest level of professional objectivity in gathering, evaluating and communicating information about the activity or process being examined. Internal auditors must make a balanced assessment of all the relevant circumstances and not be unduly influenced by their own interests or by others in forming judgements.
16. Auditors will complete, on an annual basis, a Declaration of Interests form and submit it to the Audit Manager for review and authorisation. Any declarations will be used to ensure that there are no conflicts of interest in the audits allocated and to demonstrate transparency. The Group Auditor will not allocate audits to officers where potential conflicts have been identified.
17. The Audit Manager will confirm to the Governance and Audit Committee at least annually the organisational independence of the internal audit activity.

## **Responsibility**

18. The scope of internal auditing encompasses, but is not limited to, the examination and evaluation of the adequacy and effectiveness of the organisation's governance, risk management and internal control processes in relation to the organisation's defined goals and objectives. Internal control objectives considered by internal audit include:
  - Consistency of operations or programmes with established objectives and goals and effective performance
  - Effectiveness and efficiency of operations and employment of resources
  - Compliance with significant policies, plans, procedures, laws and regulations
  - Reliability and integrity of management and financial information processes including the means to identify, measure, classify and report such information
  - Safeguarding of assets.
19. Internal Audit is responsible for evaluating all processes of the Council, including governance processes and risk management processes. It also assists the Governance and Audit Committee in evaluating the quality of performance of external auditors and maintains a proper degree of coordination with external audit.

20. Internal audit may perform consulting and advisory services related to governance, risk management and control, as appropriate for the Council. It may also evaluate specific operations at the request of Governance and Audit Committee or management as appropriate.
21. When notified of suspected fraud, corruption or impropriety, the Audit Manager will take appropriate actions in line with the Council's Fraud, Bribery and Corruption Policy for the matter to be properly investigated.
22. Based on its activity, Internal Audit is responsible for reporting significant risk exposures and control issues identified to the Governance and Audit Committee and senior management including fraud risks, governance issues and other matters needed or required.
23. The Governance and Audit Committee has a Terms of Reference, which defines the area in which it operates, and this is set out in Appendix D. The Terms of Reference are reviewed on a periodic basis.

### **Internal Audit Plan**

24. At least annually, the Audit Manager will submit to the Governance and Audit Committee an internal audit plan for review and approval including risk assessment criteria. The internal audit plan will include resource requirements for the next financial year. The Audit Manager will communicate the impact of resource limitations and significant interim changes to senior management and the Governance and Audit Committee.
25. The internal audit plan will be developed based on a prioritisation of all auditable areas using a risk-based methodology including input of senior management and Governance and Audit Committee. Prior to submission to the Governance and Audit Committee for approval, the plan may be discussed with appropriate senior management. Any significant deviation from the approved internal audit plan will be communicated through the periodic activity reporting process.

### **Reporting and Monitoring**

26. An audit output will be prepared and issued by the Audit Manager following the conclusion of each internal audit engagement and will be distributed as appropriate. Internal audit results will be communicated to the Governance and Audit Committee in accordance with the Audit Protocol, and on a basis which reflects the significance of findings.
27. The audit output may include management's response and corrective action taken or to be taken in regard to the specific findings and recommendations. Management's response, whether included within the original audit output or provided thereafter by management of the audited area will include



a timetable for anticipate completion of action to be taken and an explanation for any corrective action that will not be implemented.

28. The internal audit activity will be responsible for appropriate follow up on engagement findings and recommendations. All significant findings will remain in an open issues file until cleared.

### **Quality Assurance and Improvement Programme - QAIP**

29. The internal audit activity will maintain a Quality Assurance and Improvement Programme that covers all aspects of the internal audit activity. The programme will include an evaluation of the internal audit activity's conformance with the Public Sector Internal Audit standards, encompassing all mandatory elements of the IPPF, including an evaluation of whether internal auditors apply the Code of Ethics. The programme also assesses the efficiency of the internal audit activity and identifies opportunities for improvement.

30. The Audit Manager is responsible upholding the Audit Charter, for ongoing assurance to senior management and Governance and Audit Committee on conformance with the Code of Ethics and the Standards, and for reporting audit performance, critical findings and trends in respect of the audit plan.

31. The Audit Manager will communicate to senior management and Governance and Audit Committee on the internal audit activity's quality assurance and improvement programme, comprising the results of:

- ongoing internal quality assurance reviews,
- annual assessments against the Local Government Application Note,
- external assessments conducted at least every five years.

32. Action taken to ensure that the Quality Assurance and Improvement Programme is effective is set out in Appendix E. It is supplemented by the Audit Protocol, which provides an outline of the audit process from planning to reporting, as contained in Appendix F.

## **CODE OF ETHICS**

### **Public Sector Requirement**

Internal Auditors in UK public sector organisations must conform to the Code of Ethics as set out below. If individual Internal Auditors have membership of another professional body then he or she must also comply with the relevant requirements of that organisation.

The purpose of the Institute's Code of Ethics is to promote an ethical culture in the profession of Internal Auditing. A code of ethics is necessary and appropriate for the profession of Internal Auditing, founded as it is on the trust placed in its objective assurance about risk management, control and governance.

The Institute's Code of Ethics extends beyond the definition of Internal Auditing to include two essential components:

- 1. Principles that are relevant to the profession and practice of Internal Auditing;

and

- 2. Rules of Conduct that describe behaviour norms expected of Internal Auditors.

These rules are an aid to interpreting the Principles into practical applications and are intended to guide the ethical conduct of Internal Auditors.

The Code of Ethics provides guidance to Internal Auditors serving others. 'Internal Auditors' refers to Institute members and those who provide Internal Auditing services within the definition of Internal Auditing.

### **Applicability and Enforcement**

This Code of Ethics applies to both individuals and entities that provide Internal Auditing services. For Institute members, breaches of the Code of Ethics will be evaluated and administered according to the Institute's Disciplinary Procedures. The fact that a particular conduct is not mentioned in the Rules of Conduct does not prevent it from being unacceptable or discreditable and, therefore, the member liable to disciplinary action.

### **Public Sector Interpretation**

The 'Institute' here refers to the Institute of Internal Auditors. Disciplinary procedures of other professional bodies and employing organisations may apply to breaches of this Code of Ethics.

## **1. Integrity**

### *Principle*

The integrity of Internal Auditors establishes trust and thus provides the basis for reliance on their judgement.

### **Rules of Conduct**

Internal Auditors:

- 1.1 Shall perform their work with honesty, diligence and responsibility.
- 1.2 Shall observe the law and make disclosures expected by the law and the profession.
- 1.3 Shall not knowingly be a party to any illegal activity, or engage in acts that are discreditable to the profession of Internal Auditing or to the organisation.
- 1.4 Shall respect and contribute to the legitimate and ethical objectives of the organisation.

## **2. Objectivity**

### *Principle*

Internal Auditors exhibit the highest level of professional objectivity in gathering, evaluating and communicating information about the activity or process being examined.

Internal Auditors make a balanced assessment of all the relevant circumstances and are not unduly influenced by their own interests, or by others, in forming judgements.

### **Rules of Conduct**

Internal Auditors:

- 2.1 Shall not participate in any activity or relationship that may impair or be presumed to impair their unbiased assessment. This participation includes those activities or relationships that may be in conflict with the interests of the organisation.
- 2.2 Shall not accept anything that may impair or be presumed to impair their professional judgement.
- 2.3 Shall disclose all material facts known to them that, if not disclosed, may distort the reporting of activities under review.

### **3. Confidentiality**

#### *Principle*

Internal Auditors respect the value and ownership of information they receive and do not disclose information without appropriate authority, unless there is a legal or professional obligation to do so.

#### **Rules of Conduct**

Internal Auditors:

- 3.1 Shall be prudent in the use and protection of information acquired in the course of their duties.
- 3.2 Shall not use information for any personal gain or in any manner that would be contrary to the law or detrimental to the legitimate and ethical objectives of the organisation.

### **4. Competency**

#### *Principle*

Internal Auditors apply the knowledge, skills and experience needed in the performance of Internal Auditing services.

#### **Rules of Conduct**

Internal Auditors:

- 4.1 Shall engage only in those services for which they have the necessary knowledge, skills and experience.

- 4.2 Shall perform Internal Auditing services in accordance with the International Standards for the Professional Practice of Internal Auditing.
- 4.3 Shall continually improve their proficiency, effectiveness and quality of their services.

Internal auditors must also have regard to the Committee on Standards of Public Life's Seven Principles of Public Life, information on which can be found at [www.public-standards.gov.uk](http://www.public-standards.gov.uk)

## **CORE PRINCIPLES**

### **FOR THE PROFESSIONAL PRACTICE OF INTERNAL AUDITING**

The Internal Audit service is delivered through application of ten Core Principles, which taken as a whole, articulate internal audit effectiveness.

The following Core Principles underpin the mission of the Internal Audit service.

*'To enhance and protect organisational value by providing risk based and objective assurance, advice and insight'.*

1. Demonstrates integrity
2. Demonstrates competence and due professional care
3. Is objective and free from undue influence (independent)
4. Aligns with the strategies, objectives, and risks of the organisation
5. Is appropriately positioned and adequately resourced
6. Demonstrates quality and continuous improvement
7. Communicates effectively
8. Provides risk-based assurance
9. Is insightful, proactive, and future-focused
10. Promotes organisational improvement

## AUDIT ACTIVITY & RESOURCES

### Resources

1. **Audit Manager** -1 FTE - responsible for leading and managing the audit and investigation teams in delivering their roles, as set out within the Public Sector Internal Audit Standards (PSIAS), and other professional Codes of Practice.
2. **Audit Team** – ~~8.96~~ **7.82** FTE - who undertake system based audits, financial audits, provide advice and guidance to clients on a wide range of matters, and undertake work around efficiency and value for money, supported by an Audit Assistant.
3. **Investigation Team** - 2.42 FTE - dedicated to the prevention, detection and investigation of suspected fraud or financial impropriety.
4. All audit staff are required to maintain the highest standards of professional practice, and comply with professional Codes of Practice. The Public Sector Internal Audit Standards are followed in all aspects of internal audit work undertaken.
5. For the purpose of the Public Sector Internal Audit Standards, the Governance and Audit Committee acts as the “Board”, members of the Senior Management Team represent ‘Senior Management’, and the Corporate Director of Resources & Section 151 Officer is the Senior Manager overseeing the Internal Audit Function. The Audit Manager is the Chief Audit Executive.
6. All auditors and investigators are suitably qualified and collectively offer a wide range of skills, experience and knowledge.
  - In the Audit team, there are two qualified Accountants, one Chartered Internal Auditor, two Certified Internal Auditors and **three most other auditors are** qualified Accounting Technicians. A further member is studying for a Certified Information Systems Auditor (CISA) qualification, **and in addition to the substantive resource the team benefits from a CIPFA Trainee placement.**
  - The Investigation team is led by a Group Auditor who has the CIPFA Certificate in Investigative Practice, and investigators are professionally trained. Two members are professionally qualified counter fraud officer’s, accredited with Portsmouth University, with the third team member being a former police officer with many years of professional expertise.
7. Ongoing development and training of auditors is fundamental to the delivery of an effective and professional audit and Investigation services. The Council’s Personal Review Scheme is fully adopted and the teams assess themselves against the skills required for their respective roles. This assists in the identification of team and individual development and training opportunities within a robust performance management framework.

**GOVERNANCE AND AUDIT COMMITTEE  
TERMS OF REFERENCE****Governance**

The Governance and Audit Committee is one of the Council's Governance Committees. It discharges the following duties in accordance with its statement of purpose, and reports to full Council.

**Statement of Purpose**

The committee's purpose is to provide an independent and high-level focus on the adequacy of governance, risk and control arrangements, and the performance assessment of the Council. Its role in ensuring there is sufficient assurance over governance, risk and control gives greater confidence to all those charged with governance that those arrangements are effective. The committee has oversight of both internal and external audit, together with the financial and governance reports, helping to ensure there are adequate arrangements in place for both internal challenge and public accountability.

The committee is to seek assurance that the budgetary control systems (as an internal control) of the council are operating effectively. The scrutiny of spend falls within the remit of the Council's Scrutiny Committees

**Governance, Performance, Risk & Control**

- To review the Council's corporate governance arrangements against the good governance framework, including the ethical framework, and consider the Code of Corporate Governance.
- To review the Council's draft annual Self-Assessment Report, and make any appropriate recommendations for changes.
- To review the Council's draft response to the Panel Performance Assessment Report, and make any appropriate recommendations for changes.
- To review the Council's draft response to any Auditor General's recommendations arising from a 'special inspection' in respect of the Council's performance requirements, and to make any appropriate recommendations for changes.
- To review and assess the authority's ability to handle complaints effectively, and make any associated reports and recommendations.
- To consider the Council's arrangements to secure value for money and review assurances and assessments on the effectiveness of these arrangements.
- To consider reports on the effectiveness of financial management arrangements, including compliance with CIPFA's Financial Management Code.
- To monitor the effective development and operation of risk management in the Council.
- To monitor progress in addressing risk-related issues reported to the Committee.
- To consider reports on the effectiveness of internal controls and monitor the implementation of agreed actions.



- To review the assessment of fraud risks and potential harm to the Council from fraud and corruption.
- To monitor the Counter-fraud strategy, actions and resources.
- To review the governance and assurance arrangements for significant partnerships or collaborations.

## **Financial and governance reporting**

### **Governance reporting**

- To review the Annual Governance Statement (AGS) prior to approval and consider whether it properly reflects the risk environment and supporting assurances, including the Audit Manager's internal audit's annual opinion on the overall adequacy and effectiveness of the Council's framework of governance, risk management and internal control.
- To consider whether the annual evaluation for the AGS fairly concludes that governance arrangements are fit for purpose, supporting the achievement of the authority's objectives.

### **Financial Reporting**

- To monitor the arrangements and preparations for financial reporting to ensure that statutory requirements and professional standards can be met.
- To review the annual statement of accounts. Specifically, to consider whether appropriate accounting policies have been followed and whether there are concerns arising from the financial statements or from the audit that need to be brought to the attention of the Council.
- To consider the external auditor's report to those charged with governance on issues arising from the audit of the accounts.
- To seek assurances on the arrangements for the management of the authority's financial affairs.

### **Treasury Management**

- To seek assurances that the Council has complied with the Treasury Management Strategy and Practices by demonstrating effective control of the associated risks and pursuing optimum performance consistent with those risks.
- To review the treasury management policy and procedures to be satisfied that controls are satisfactory.
- To review the treasury risk profile and adequacy of treasury risk management processes.
- To review assurances on treasury management (for example, an internal audit report, external audit or other review).
- To develop awareness and understanding of treasury matters, and to receive regular reports on activities, issues and trends to support the committee's understanding of treasury management activities. *(The committee is not responsible for the regular monitoring of treasury management policies and practices, which are the responsibility of the Cabinet, under the Council's Scheme of*

*Delegations (Section 2, paragraph 10), the approved Treasury Management Policy Statement and the Third Clause of Treasury Management, as set out therein).*'

### **Arrangements for audit and assurance**

- To consider the Council's framework of assurance and ensure that it adequately addresses the risk and priorities of the Council.

### **External Audit**

- To consider the external auditor's annual letter, relevant reports, and the report to those charged with governance.
- To consider specific reports as agreed with the external auditors.
- To comment on the scope and depth of external audit work and to ensure it gives value for money.
- To consider commissioning additional work from internal and external audit.
- To advise and make recommendations on the effectiveness of relationships between external and internal audit and other inspector agencies or relevant bodies.
- To provide auditors with free and unfettered access to the Governance and Audit Committee Chair and the opportunity for a private meeting with the Committee.

### **Internal Audit**

- To approve the Internal Audit Charter.
- To review proposals in relation to the appointment of external providers of internal audit services and to make recommendations.
- To approve the risk-based internal audit plan, including internal audit's resource requirements, the approach to using other sources of assurances and any work required to place reliance upon those other sources.
- To approve significant interim changes to the risk based internal audit plan and resource requirements.
- To make appropriate enquiries of both management and the Audit Manager to determine if there are any inappropriate scope or resource limitations.
- To consider any impairments to independence or objectivity of the Audit Manager arising from additional roles or responsibilities outside of internal auditing and to approve and periodically review safeguards to limit such impairments.
- To consider reports from the Audit Manager on Internal Audit's performance during the year
  - including the performance of external providers of internal audit services. These will include:
  - Updates on the work of internal audit including key findings, issues of concern and action in hand as a result of internal audit work
  - Regular reports on the results of the Quality Assurance and Improvement Programme (QAIP)

- Reports on instances where the internal audit function does not conform to the PSIAS and Local Government Application Note (LGAN) considering whether the non-conformance is significant enough that it must be included in the Annual Governance Statement.
- To consider the Audit Manager's annual report:
  - The statement of the level of conformance with the PSIAS and LGAN and the results of the QAIP that support the statement (these will indicate the reliability of the conclusions of Internal audit)
  - The opinion on the adequacy and effectiveness of the Council's framework of governance, risk management and control together with a summary of the work supporting the opinion (these will assist the Committee in reviewing the Annual Governance Statement).
- To consider summaries of specific internal audit reports as requested.
- To receive reports outlining the action taken where the Audit Manager has concluded that management has accepted a level of risk that may be unacceptable to the authority or there are concerns about progress with the implementation of agreed actions.
- To contribute to the Quality Assurance and Improvement Programme and in particular the external quality assessment of internal audit that takes place at least once every five years.
- To consider a report on the effectiveness of internal audit to support the Annual Governance Statement, where required to do so by the Accounts and Audit Regulations.
- To provide free and unfettered access to the Governance and Audit Committee Chair for the Audit Manager, including the opportunity for a private meeting with the Committee.

### **Accountability Arrangements**

- To report to Council on the Committee's findings, conclusions and recommendations concerning the adequacy and effectiveness of the governance, risk management and internal control frameworks, financial reporting arrangements and internal and external audit functions.
- To report to Council on an annual basis and to publish an annual report on the Committee's work, its performance in relation to its Terms of Reference, and its effectiveness in meeting its purpose including a conclusion on compliance with the CIPFA Position Statement.
- To raise the profile of probity generally within the Council and to report on matters of concern to the individual Cabinet Member, relevant Scrutiny Committee, Cabinet or to Council as necessary and appropriate.
- To work in synergy with the five Scrutiny Committees of the Council and liaise with other Council Committees as and when appropriate to avoid duplication in work programmes.

### **Training & Development**

- To attend relevant training sessions in accordance with the Member Development Programme including specialist training tailored for Members of the Governance and Audit Committee

**Appendix E**

## QUALITY ASSURANCE AND IMPROVEMENT PROGRAMME (QAIP)

A Quality Assurance and Improvement Programme (standard 1300) is designed to enable an evaluation of the Internal Audit section's conformance with the Standards and an evaluation of whether internal auditors apply the Code of Ethics.

The programme also assesses the efficiency and effectiveness of the internal audit activity and is used to identify and deliver opportunities for improvement.

Key principles of the QAIP:

- The Audit Manager has established a system of ongoing monitoring of conformance with the standards and the Code of Ethics as part of each audit engagement, and a system of periodic review and reporting.
- Regular periodic reports and an Annual Internal Audit Report are presented to the Section 151 Officer and to the Governance and Audit Committee.
- There is a commitment to undergoing an external inspection on conformance to PSIAS every five years.

To support the delivery of an efficient and effective service:

- Each Directorate has a relationship manager with whom they hold regular meetings to discuss risks and emerging issues, progress against and development of the audit plan, and audit outcomes and feedback.
- The Audit Manager has regular contact with the Governance and Audit Committee Chair, Audit Wales, Senior Managers including the Chief Executive and the Section 151 Officer, and peers within Welsh Local Authorities and the Core UK Cities.
- Benchmarking exercises are undertaken in order to assess performance against other comparable organisations and report on significant variances, with action plans developed and implemented where appropriate.
- Annual personal reviews include auditor assessments against a skills and competency framework, leading to development goals and targets.
- Quality assurance is delivered through monitoring and review processes at key stages within the audit, to ensure all relevant Codes of Practice and Standards are adhered to.
- All Auditors are required to comply with the Code of Ethics, any other professional standards for the associations to which they belong and the Council's Codes of Conduct.

## QAIP - OPERATIONAL APPROACH

The QAIP is built around a performance management approach, which involves 'setting expectations', 'reviewing performance', and 'reporting performance' at individual auditor and team levels. The application of these control stages are summarised as follows.

### 1. Setting expectations - With clear expectations in place, auditors can focus on delivery.

- ✓ **Audit Allocation** - Each auditor has a quarterly allocation of work, which is stretching but achievable. Auditors are responsible for delivering their allocation effectively and on time.
- ✓ **Scoping and Objectives** – Each auditor has clear and documented objectives for each audit engagement, that they are responsible for delivering.
- ✓ **Audit 'Pit Stop'** - When half of the audit time is used, a senior team member completes a short and sharp review of progress against the audit objectives. This can either result in assurance that the audit is being delivered effectively, or it leads to expectations being re-set, with actions developed for the auditor to conclude a high quality audit engagement on time.
- ✓ **Personal Reviews** – Each year delivery, training and development goals and objectives are established for each auditor, in recognition of the individual and collective skills needed to deliver the risk-based plan effectively in the current and medium term.

### 2. Reviewing Performance - Expectations are revisited in quality assurance and control reviews.

- ✓ **Monitoring** - Each auditor attends a monthly monitoring meeting, through which the delivery of their 'Audit Allocation' is reviewed, issues are identified and addressed.
- ✓ **Quality Assurance Review** - Each audit is subject to a quality assurance review by a member of the audit management team, to ensure high quality delivery in accordance with the Code of Ethics and the Standards. The review considers the quality of evidence to support the audit 'Objectives', and the delivery of actions resulting from the audit 'Pit Stop'.
- ✓ **Post Audit Assessment** – Upon conclusion of each audit, the auditor, and a senior team member review the auditor's performance against best practice technical and behavioural qualities. A client satisfaction survey is also used to identify the audit delivery and value from the client's perspective. Any development needs are identified and progressed.
- ✓ **Six Monthly Personal Review** – Progress is measured against the objectives and targets in each Auditor's 'Personal Review', taking account of the findings and outcomes from the activities in the 'Reviewing Performance' control stage. It can lead to new objectives, targets and support.

### 3. Reporting Performance - A range of performance measures are used for reporting and review.

- Core performance measures relate to the audits delivered on time, client satisfaction, recommendations agreed / implemented, productivity and the delivery of personal objectives.
- Performance information is regularly monitored by the Audit Manager and is considered by the Finance Management Team and the Governance and Audit Committee on a quarterly basis.
- On an annual basis, the Audit Manager reviews and reports on the application and findings of the performance management Framework that underpins the QAIP to the Governance and Audit Committee. An external assessment of conformance with the PSIAS is completed and reported at least every five years.

## QAIP – OPERATIONAL APPROACH (DIAGRAM)

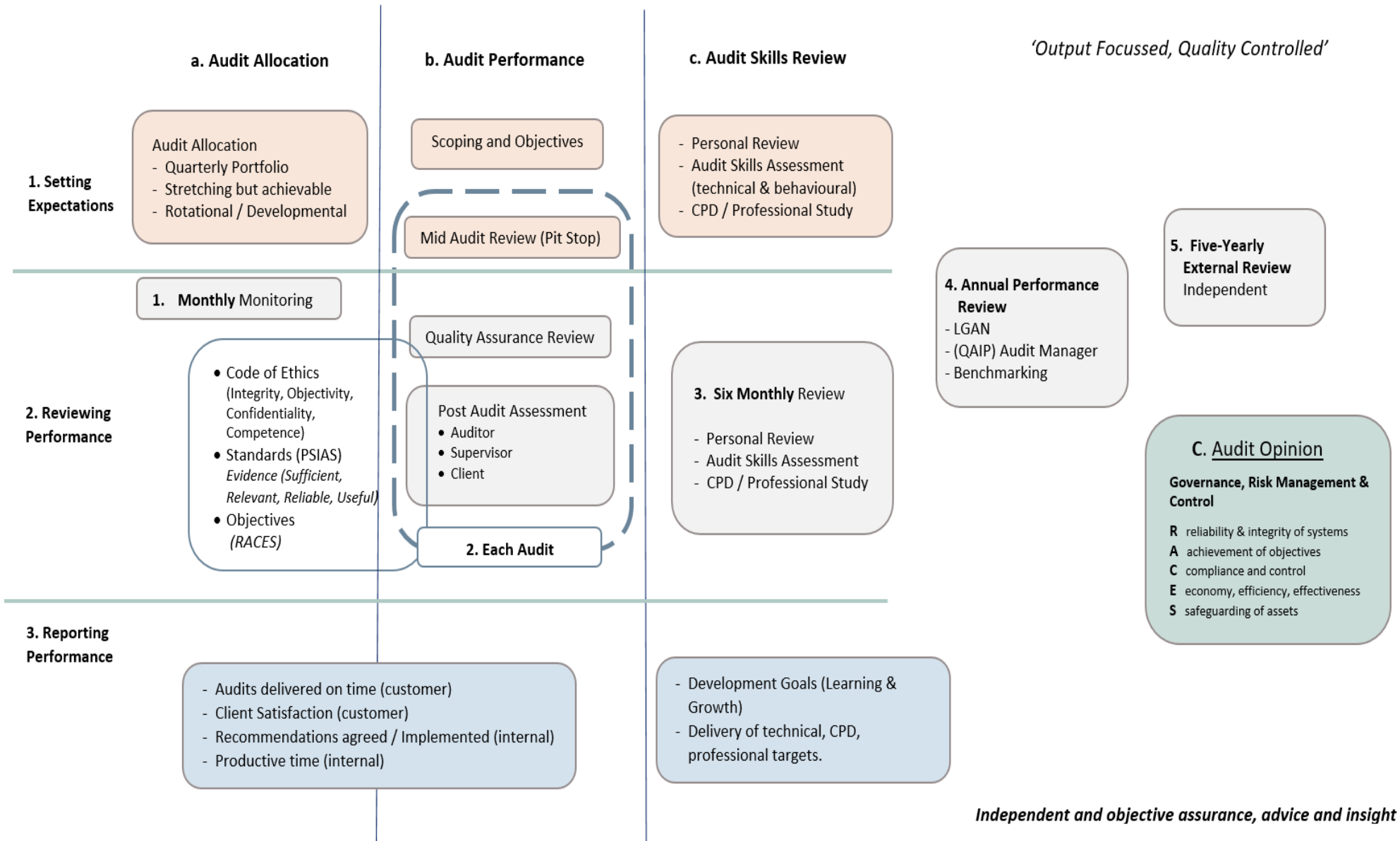

*The Audit Protocol provides an outline of the audit process from planning to reporting.*

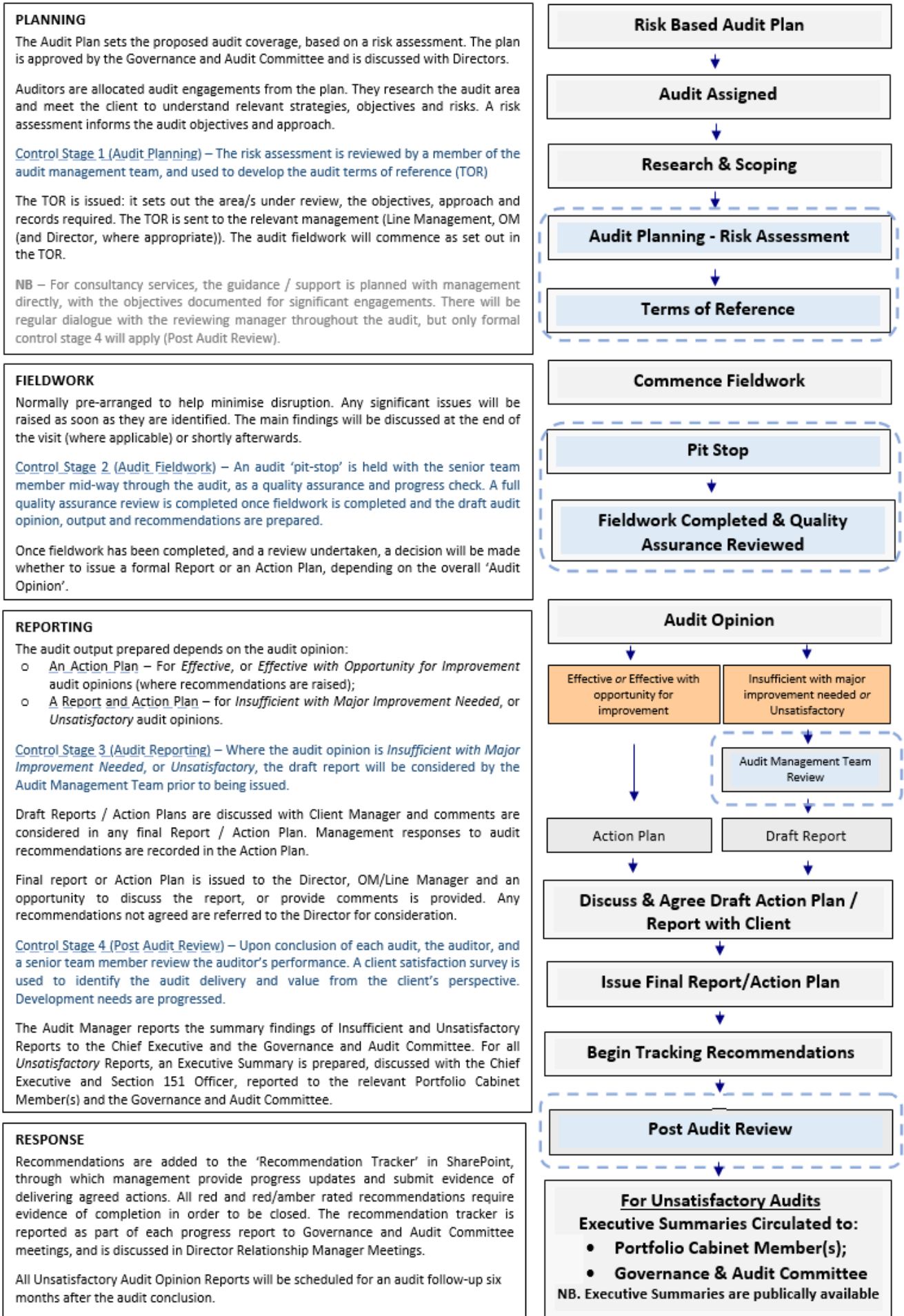

This page is intentionally left blank



**DRAFT SUMMARY AUDIT PLAN, 2024/25**

<b>Fundamental Audits - S151 Assurance</b>	<b>Type of engagement</b>	<b>CIPFA classification</b>	<b>Audit plan 2023/24</b>	<b>Audit plan 2024/25</b>
Purchasing Payments & Processing	Assurance	Chargeable	50	50
Payroll & HR	Assurance	Chargeable	50	50
Council Tax	Assurance	Chargeable	0	20
NNDR	Assurance	Chargeable	20	0
Housing Benefit / Local Housing Allowances / CTRS	Assurance	Chargeable	0	20
Treasury Management	Assurance	Chargeable	20	0
Main Accounting	Assurance	Chargeable	20	0
Income and Debtors	Assurance	Chargeable	20	20
Asset Management	Assurance	Chargeable	20	20
Housing Rents	Assurance	Chargeable	10	0
<b>Total</b>			<b>210</b>	<b>180</b>
<b>Corporate Audit</b>	<b>Type of engagement</b>	<b>CIPFA classification</b>	<b>Audit plan 2023/24</b>	<b>Audit plan 2024/25</b>
Risk Management Arrangements	Assurance	Chargeable	15	15
Governance Arrangements	Assurance	Chargeable	20	20
Scrutiny	Assurance	Chargeable	0	0
Ethics and Values	Assurance	Chargeable	0	20
Wellbeing of Future Generations Act	Assurance	Chargeable	20	0
Performance Management	Assurance	Chargeable	0	0
Health and Safety	Assurance	Chargeable	0	20
Safeguarding	Assurance	Chargeable	0	20
Information Governance	Assurance	Chargeable	20	0
Delegation and decision making	Assurance	Chargeable	20	20
Programmes and projects	Assurance	Chargeable	20	20
Investigation Processes	Assurance	Chargeable	0	0
Contract Audit	Assurance	Chargeable	40	40
Partnership / Arm's-length Assurance	Assurance	Chargeable	0	0
Education – SOP	Assurance	Chargeable	20	20
Directory Recovery Planning	Assurance	Chargeable	0	0
ICT Audit	Assurance	Chargeable	30	30
Value for Money studies	Assurance	Chargeable	30	30
Taxation (incl. VAT)	Assurance	Chargeable	20	0
System Development	Assurance	Chargeable	30	30
National Fraud Initiative	Assurance	Chargeable	10	10
Pensions and Investments	Assurance	Chargeable	0	20
Insurance	Assurance	Chargeable	0	0
Mileage & subsistence	Assurance	Chargeable	15	0
Fleet Management (pool cars, grey fleet, etc.)	Assurance	Chargeable	20	0
Procurement	Assurance	Chargeable	20	20

Stores	Assurance	Chargeable	10	20
Business Continuity	Assurance	Chargeable	20	0
Members Allowances	Assurance	Chargeable	0	0
TBA	TBC	Chargeable	0	0
<b>Total</b>			<b>380</b>	<b>355</b>
<b>Service specific audits</b>	<b>Type of engagement</b>	<b>CIPFA classification</b>	<b>Audit plan 2023/24</b>	<b>Audit plan 2024/25</b>
Service / Process Consultancy	Consultation	Chargeable	30	30
Resources	TBC	Chargeable	40	40
Governance and Legal Services	TBC	Chargeable	40	30
People and Communities	TBC	Chargeable	30	30
Adults, Housing & Communities	TBC	Chargeable	125	150
Childrens' Services	TBC	Chargeable	40	60
Economic Development	TBC	Chargeable	65	120
Education and Lifelong Learning	TBC	Chargeable	150	190
Planning, Transportation and Environment	TBC	Chargeable	45	60
<b>Total</b>			<b>565</b>	<b>710</b>
<b>External</b>	<b>Type of engagement</b>	<b>CIPFA classification</b>	<b>Audit plan 2023/24</b>	<b>Audit plan 2024/25</b>
External clients	Assurance	Chargeable	20	20
Grants	Assurance	Chargeable	15	15
<b>Total</b>			<b>35</b>	<b>35</b>
<b>Contingencies</b>	<b>Type of engagement</b>	<b>CIPFA classification</b>	<b>Audit plan 2023/24</b>	<b>Audit plan 2024/25</b>
General Audit ( <i>provision for carried forward audits / other work / recommendation tracking</i> )		Chargeable	70	100
<b>Total</b>			<b>70</b>	<b>100</b>
<b>Management</b>	<b>Type of engagement</b>	<b>CIPFA classification</b>	<b>Audit plan 2023/24</b>	<b>Audit plan 2024/25</b>
Corporate work – Committee, Audit Wales etc.	Consultation	Chargeable	50	50
Assurance mapping	Consultation	Chargeable	20	20
CRSA development	Consultation	Chargeable	10	20
Process development	Consultation	Chargeable	15	15
Work for Audit Manager	Consultation	Chargeable	30	50
Planning, monitoring, reporting (& reviewing)	Consultation	Chargeable	30	53
Review of financial rules etc.	Consultation	Chargeable	60	40
General advice and guidance	Consultation	Chargeable	20	20
<b>Total</b>			<b>235</b>	<b>268</b>

<b>Audit Team Non Chargeable Leave/Sickness/Training</b>	<b>Type of engagement</b>	<b>CIPFA classification</b>	<b>Audit plan 2023/24</b>	<b>Audit plan 2024/25</b>
Annual and Additional / Unpaid Leave (incl. use of carry forward leave)		Non-chargeable	297	292
Public Holidays		Non-chargeable	80	63
Maternity / Paternity / Parental Leave		Excluded	0	0
Sickness		Non-chargeable	70	77
Professional Studies		Non-chargeable	39	56
Courses and seminars		Non-chargeable		
Corporate Wellbeing		Non-chargeable	20	22
<b>TOTAL AUDIT TEAM NON CHARGEABLE LEAVE/SICKNESS/TRAINING DAYS</b>			<b>506</b>	<b>510</b>
<b>Audit Team Non Chargeable Other</b>	<b>Type of engagement</b>	<b>CIPFA classification</b>	<b>Audit plan 2023/24</b>	<b>Audit plan 2024/25</b>
General Admin. (no identifiable client)		Non-chargeable	75	79
General management		Non-chargeable	25	25
Staff Development		Non-chargeable	42	45
Internal Audit meetings (such as team meetings)		Non-chargeable	71	112
Non-audit duties		Non-audit	80	62
<b>TOTAL AUDIT TEAM NON CHARGEABLE OTHER DAYS</b>			<b>293</b>	<b>323</b>
<b>TOTAL AUDIT TEAM CHARGEABLE DAYS</b>			<b>1495</b>	<b>1648</b>
<b>TOTAL AUDIT TEAM NON CHARGEABLE DAYS</b>			<b>799</b>	<b>833</b>
<b>TOTAL DAYS</b>			<b>2294</b>	<b>2481</b>
<b>Investigations</b>			<b>Audit plan 2023/24</b>	<b>Audit plan 2024/25</b>
General			629	629
<b>Total</b>			<b>629</b>	<b>629</b>
<b>Investigations Non Chargeable Leave/Sickness/Training</b>	<b>Type of engagement</b>	<b>CIPFA classification</b>	<b>Audit plan 2023/24</b>	<b>Audit plan 2024/25</b>
Annual Leave (incl. use of carry forward leave)		Non-chargeable	76	75
Public Holidays		Non-chargeable	22	17
COVID-related absences		Non-chargeable	0	0
Sickness		Non-chargeable	17	17
Professional Studies		Non-chargeable	5	5
Courses and seminars		Non-chargeable		
Corporate Wellbeing		Non-chargeable	6	6
<b>TOTAL INVESTIGATIONS NON CHARGEABLE LEAVE/SICKNESS/TRAINING DAYS</b>			<b>126</b>	<b>120</b>

			Audit plan, 2023/24	Audit plan 2024/25
<b>Investigations Non Chargeable Other</b>				
General Admin.		Non-chargeable	8	8
General management		Non-chargeable	10	10
Staff Development		Non-chargeable	15	15
Internal Audit meetings		Non-chargeable	18	18
<b>TOTAL INVESTIGATIONS NON CHARGEABLE OTHER DAYS</b>			<b>51</b>	<b>51</b>
<b>TOTAL INVESTIGATIONS CHARGEABLE DAYS</b>			<b>452</b>	<b>458</b>
<b>TOTAL INVESTIGATIONS NON CHARGEABLE DAYS</b>			<b>177</b>	<b>171</b>
<b>TOTAL DAYS</b>			<b>629</b>	<b>629</b>

## Audit Wales Work Programme and Timetable – Cardiff Council

Quarterly Update: 31 December 2023

### Annual Audit Summary

Description	Timetable	Status
A report summarising completed audit work since the last Annual Audit Summary, which was issued in July 2023.	Spring 2024	Planning

### Financial Audit work

Description	Scope	Timetable	Status
<b>Audit of the Council's 2022-23 statement of accounts</b>	Providing the audit opinion on the Council's 2022-23 statement of accounts, including the Housing Revenue Account, Cardiff Harbour Authority, Cardiff Port Health Authority, Glamorgan Archives Joint Committee and Prosiect Gwyrdd Joint Committee.	October – March 2024	<p>Council's statements of accounts audit – ongoing.</p> <p>Joint Committees:</p> <ul style="list-style-type: none"> <li>• Glamorgan Archives – completed 9 January 2024.</li> <li>• Prosiect Gwyrdd – completed 9 January 2024.</li> </ul>

Description	Scope	Timetable	Status
<b>Audit of the Council's 2022-23 Grants and Returns</b>	The audit of Housing Benefit, Teachers Pension and Non-Domestic Rates.	November 2023 – March 2024	Teachers Pension and Non-domestic rates completed. Housing Benefit to be started.
<b>Audit of Cardiff and Vale of Glamorgan Pension Fund's Annual Report (including the statement of accounts)</b>	Providing the audit opinion on the 2022-23 Cardiff and Vale of Glamorgan Pension Fund's statement of accounts.	November 2023	Completed November 2023.

## Performance Audit work

2022-23 Performance Audit work	Scope	Timetable	Status
<b>Assurance and Risk Assessment</b>	<p>Project to identify the level of audit assurance and/or where further audit work may be required in future years in relation to risks to the Council putting in place proper arrangements to secure value for money in the use of resources and acting in accordance with the sustainable development principle.</p> <ul style="list-style-type: none"> <li>Financial position</li> </ul>	Ongoing monitoring of financial position	Ongoing

2022-23 Performance Audit work	Scope	Timetable	Status
	<ul style="list-style-type: none"> <li data-bbox="416 658 863 689">• Capital programme management</li>   <li data-bbox="416 1272 863 1361">• Use of performance information – with a focus on service user feedback and outcomes</li>   <li data-bbox="416 1469 836 1500">• Setting of well-being objectives</li> </ul>	<p data-bbox="938 658 1098 748">September – December 2023</p> <p data-bbox="938 1272 1075 1361">February – September 2023</p> <p data-bbox="938 1469 1098 1532">March – May 2023</p>	<p data-bbox="1185 658 1362 1196">AW will not undertake detailed work at all councils as part of our 2022-23 work programme. We are currently exploring our options for undertaking a detailed piece of work on this topic either in 2023-24 or future years.</p> <p data-bbox="1185 1272 1331 1397">Final report issued 1<sup>st</sup> December 2023</p> <p data-bbox="1185 1469 1369 1559">Final report issued 1<sup>st</sup> June 2023</p>
<b>Thematic Review – Unscheduled Care</b>	<p data-bbox="416 1639 879 1953">A cross-sector review focusing on the flow of patients out of hospital. This review will consider how the Council is working with its partners to address the risks associated with the provision of social care to support hospital discharge, as well as prevent hospital admission. The work will also consider what steps are being taken to provide medium to longer-term solutions.</p>	<p data-bbox="938 1639 1118 1702">August 2022 – October 2023</p>	<p data-bbox="1185 1639 1369 1729">Reporting from February 2024 onward.</p>

2022-23 Performance Audit work	Scope	Timetable	Status
<b>Thematic review – Digital</b>	A review of councils’ strategic approach to digital, and the extent to which this has been developed in accordance with the sustainable development principle; and that it will help to secure value for money in the use of councils’ resources.	January – September.	Final report issued 3 <sup>rd</sup> January 2024
<b>Local project – Equalities Impact Assessments</b>	The audit will focus on the Council’s arrangements to ensure its staff are completing equality impact assessments which comply with the Council’s Equalities and Inclusion strategy.	March to August 2023	Clearance



2023-24 Performance Audit work	Scope	Timetable	Status
<b>Assurance and Risk Assessment</b>	Project to identify the level of audit assurance and/or where further audit work may be required in future years in relation to risks to the Council putting in place proper arrangements to secure value for money in the use of resources and acting in accordance with the sustainable development principle.	2023-24	Ongoing
<b>Thematic review – commissioning and contract management</b>	A review focusing on how councils' arrangements for commissioning, and contract management apply value for money considerations and the sustainable development principle.	January – July 2024	Scoping
<b>Thematic review – Financial Sustainability</b>	A review of councils' financial sustainability including a focus on the actions, plans and arrangements to bridge funding gaps and address financial pressures over the medium term.	March – June 2024	Scoping
<b>Local Project</b>	Transport and Highways: we are currently scoping this work.	March – July 2024	Scoping

## Local government national studies planned/in progress

Study	Scope	Timetable	Status	Fieldwork planned at Cardiff Council
<b>Planning for sustainable development – Brownfield regeneration</b>	Review of how local authorities are promoting and enabling better use of vacant non-domestic dwellings and brownfield sites	October 2022 – September 2023	Report drafting – publication due January 2024	Yes – interview with nominated officer at seven councils and survey.
<b>Governance of special purpose authorities – National Parks</b>	Review of systems and effectiveness of governance	November 2022 – September 2023	Report drafting – publication due February 2024.	No
<b>Governance in Fire and Rescue Authorities</b>	Review of systems and effectiveness of governance	September 2023 – August 2024	Fieldwork underway	No
<b>Homelessness</b>	Examining how services are working together to progress the response to homelessness.	tbc	Scoping	tbc

## Estyn

Our link inspectors are continuing to work with Torfaen as part of our follow-up process for an authority causing significant concern. We inspected Conwy local government education service in the week beginning 6 November 2023, and the report will be published early in January 2024. We will be piloting our new inspection arrangements in the Vale of Glamorgan on the week beginning 11 March 2024. We will also be inspecting the Vale of Glamorgan's youth work services on the week beginning 19 February 2024, and the findings of that inspection will contribute to the evidence base for the LGES inspection.

We have published a report outlining the approaches of local authorities and secondary schools in promoting attendance. The report will be published on 18 January 2024.

## Care Inspectorate Wales (CIW)

CIW planned work 2023-25	Scope	Timetable	Status
<b>Thematic reviews</b>			
<b>Community Learning Disability Team (CLDT)</b>	Working with HIW we will complete a small sample of joint CLDT inspections in 2024. We will use this approach to evaluate and consider our approach to joint inspection.	2024-25	Planning
<b>Stroke pathway</b>	Working in collaboration with HIW a <a href="#">National Review of Patient Flow: a journey through the stroke pathway (hiw.org.uk)</a> has recently been published.	Complete	Published

CIW planned work 2023-25	Scope	Timetable	Status
<b>National review of Care Planning for children and young people subject to the Public Law Outline pre-proceedings</b>	<p>Purpose of the review</p> <p>To provide external scrutiny, assurance and to promote improvement regarding the quality of practice in relation to the care planning for children and young people subject to the public law outline pre-proceedings.</p> <p>To consider the extent to which practice has progressed since the publication of both the CIW 'National Review of care planning for children and young people subject to public law outline pre-proceedings' and the publication of the PLO working group report 2021 including best practice guidance.</p>	Awaiting publication	Publication January 2024
<b>Child Protection Rapid Review</b>	<p>The review looked at to what extent the current structures and processes in Wales ensure children's names are appropriately placed on, and removed from, the child protection register (CPR) when sufficient evidence indicates it is safe to do.</p> <p><a href="#"><u>Rapid review of child protection arrangements, Care Inspectorate Wales</u></a></p> <p><a href="#"><u>Rapid review of child protection arrangements - interim findings, Care Inspectorate Wales</u></a></p>	Published	Published
<b>Deprivation of Liberty Safeguards Annual Monitoring Report for Health and Social Care 2022-23</b>	<p>The <a href="#"><u>2020-21 report</u></a> was published on 7 February 2021</p> <p>The 2021-2022 report is underway</p>	<p>Published</p> <p>To be confirmed</p>	<p>Published</p> <p>Preparing</p>

CIW planned work 2023-25	Scope	Timetable	Status
<b>Joint Inspection Child Protection Arrangements (JICPA)</b>	<p>We will complete a further two multi-agency joint inspections in total.</p> <p>The findings following Denbighshire County Council have been published - <a href="#">Joint Inspectorate Review of Child Protection Arrangements (JICPA): Denbighshire 2023   Care Inspectorate Wales</a></p> <p>The findings following Bridgend County Borough Council have been published - <a href="#">Joint Inspectorate Review of Child Protection Arrangements (JICPA): Bridgend 2023   Care Inspectorate Wales</a></p> <p>The findings from Powys County Council are underway</p> <p>We will publish a national report in late spring 2024.</p>	<p>April 2023 – April 2024</p>	<p>Delivery</p>
<b>Performance review of Local Authorities</b>	<p><a href="#">We continue to inspect Local Authorities in line with our updated Code of Practice for our local authority inspection activity   Care Inspectorate Wales</a></p> <p><a href="#">How we inspect local authority services and CAF/CASS Cymru</a></p>	<p>Ongoing</p>	<p>Ongoing</p>

## Audit Wales national reports and other outputs published since December 2022

Report title	Publication date and link to report
Corporate Joint Committees – commentary on their progress	<a href="#">November 2023</a>
Governance arrangements relating to an employment dispute at Amgueddfa Cymru – National Museum Wales	<a href="#">November 2023</a>
Failures in financial management and governance and losses incurred – Harlech Community Council	<a href="#">November 2023</a>
Putting out the false alarms: Fire and Rescue Authorities’ responses to Unwanted Fire Signals	<a href="#">October 2023</a>
Covering teachers’ absence – follow-up (letter to the Public Accounts and Public Administration Committee)	<a href="#">October 2023</a>
NHS workforce – data briefing	<a href="#">September 2023</a>
Income Diversification for National Park Authorities in Wales	<a href="#">September 2023</a>
Approaches to achieving net zero across the UK	<a href="#">September 2023</a>
Springing Forward: Lessons learnt from our work on workforce and assets (in local government)	<a href="#">September 2023</a>
Local Government Financial Sustainability Data tool update (further update planned in January 2024)	<a href="#">September 2023</a>
NHS finances data tool – to 31 March 2023	<a href="#">September 2023</a>

Report title	Publication date and link to report
Public interest reports – Ammanford Town Council and Llanferres Community Council	<a href="#">September 2023</a>
Cwm Taf Morgannwg University Health Board - Quality Governance Arrangements Joint Review Follow-up	<a href="#">August 2023</a>
'Cracks in the Foundations' – Building Safety in Wales	<a href="#">August 2023</a>
Maximising EU funding – the Structural Funds Programme and the Rural Development Programme	<a href="#">June 2023</a>
Digital inclusion in Wales (including key questions for public bodies)	<a href="#">March 2023</a>
Orthopaedic Services in Wales – Tackling the Waiting List Backlog	<a href="#">March 2023</a>
Betsi Cadwaladr University Health Board – Review of Board Effectiveness	<a href="#">February 2023</a>
Welsh Government purchase of Gilestone Farm	<a href="#">January 2023</a>
Together we can – Community resilience and self-reliance	<a href="#">January 2023</a>
A Picture of Flood Risk Management	<a href="#">December 2022</a>
'A missed opportunity' – Social Enterprises	<a href="#">December 2022</a>

## Audit Wales national reports and other outputs (work in progress / planned)<sup>1, 2</sup>

Title	Indicative publication date
Ukrainian refugee services	February 2024
Betsi Cadwaladr University Health Board – review of board effectiveness follow up	February 2024
A465 Section 2 – update	February 2024
NHS quality governance	March 2024
Local government digital strategy review – national summary	March 2024
Local government use of performance information, outcomes and service user perspective – national summary	March 2024
Affordable housing	Spring 2024
Active travel	Spring 2024

<sup>1</sup> We will continue to keep our plans under constant review, taking account of the evolving external environment, our audit priorities, the context of our own resourcing and the capacity of audited bodies to engage with us. Follow up work could also lead to other outputs, as may other local audit work where we consider there is merit in a national summary output of some kind.

<sup>2</sup> We have also published to our website a paper – [Our work programme for 2023-2026](#) – that provides additional detail about our national work (including local thematic reviews). In addition to new work that we will be taking forward in 2023-24, the paper includes details about indicative topics for work to start in 2024-24 or 2025-26.



Title	Indicative publication date
Audit Committees. 'What does good look like?'. R&D work to understand the broad audit committee landscape across all sectors in Wales. Outputs to support Good Practice Exchange events and potential future audit work.	R&D work Sept – Dec 2023 Good Practice Event Spring 2024
NHS Workforce planning (national messages)	Late spring 2024
Cancer services	Late summer 2024
The senior public service	To be confirmed (scoping early 2024)
Challenges for the cultural sector	To be confirmed (starting in 2023-24)
Rebalancing care and support	To be confirmed (starting in 2023-24)
Tackling NHS waiting lists (local audit work at health boards)	To be confirmed (starting in 2023-24)
Access to education for children with Additional Learning Needs	To be confirmed (starting in 2023-24)
Addressing biodiversity decline (pan-public sector and at Natural Resources Wales)	R&D work underway September to December 2023. Data gathering with representative groups. Outputs will inform any further audit work. Pan-public sector review – Autumn 2024
Velindre Cancer Centre	To be confirmed (scoping)
Welsh Government capital and infrastructure investment	To be confirmed (scoping)

Title	Indicative publication date
Further and higher education funding and oversight – Commission for Tertiary Education and Research	To be confirmed (scoping)

## Good Practice Exchange events and resources

Title	Link to resource
The Good Practice Exchange – Our yearly round up <b>of events and resources</b>	<a href="#">December 2023</a>
<b>Integrity in the Public Sector</b> ‘Trust is built and maintained through competence, reliability, and honesty, as well as the building of genuine and sound relationships between the public sector and the public it serves. That means the public sector must be accountable for the management and delivery of public services and outcomes, for the direction and control of the work it does, the resources it manages, and for its behaviour and ethics.’ This event will look at how public services can promote a culture of integrity.	5 December 2023 10:00 – 12:00 Online
<b>Working in partnership to improve wellbeing</b> This event will bring together the North Wales Insight Partnership, the Public Service Boards and the C4C community to share wellbeing plans across the North Wales region, as well as sharing the innovative work being undertaken by a range of sectors around wellbeing in our communities. The event will provide opportunities to discuss how we can connect all of this work to deliver real change.	24 October 2023 09:30 – 16:30  Cardiff date TBC
<b>Strategy to Action: How digital makes a difference to everyday lives</b> This event will take a practical and honest view at the digital landscape in Wales and will offer practical ideas for public and third sector organisations which will help them achieve the best value for money.	27 September 2023 09:00 – 13:00 – North Wales  5 October 2023 09:00 – 13:00 – Cardiff

Title	Link to resource
<p><b>Podcast: Auditing Community Resilience</b> In this edition of The Exchange, our Local Government team discuss some of the factors that cause poverty in Wales, as well as the value provided by social enterprises, and the importance of keeping wealth in communities.</p>	<p><u><a href="#">To listen</a></u></p>

This page is intentionally left blank

**GOVERNANCE & AUDIT COMMITTEE: 23 JANUARY 2024**

---

**AUDIT WALES REPORT – USE OF PERFORMANCE INFORMATION:  
SERVICE USER PERSPECTIVE AND OUTCOMES****REPORT OF THE HEAD OF PERFORMANCE AND PARTNERSHIPS****AGENDA ITEM: 7.2**

---

**Reasons for this Report**

1. The Governance and Audit Committee's Terms of Reference requires members of the Committee:
  - To consider specific reports as agreed with the external auditors
  - To comment on the scope and depth of external audit work and to ensure it gives value for money.
2. This report provides the Governance and Audit Committee with an overview of the findings of a local report by Audit Wales, entitled "*Use of performance information: service user perspective and outcomes – City of Cardiff Council*". A copy of the report is attached as **Appendix A** to this report.

**Background**

3. During 2023, Audit Wales undertook an audit of Cardiff Council, which focused on the performance information that the Council provides to senior officers and senior elected members about the service user perspective and the outcomes of its activities, and how this information is used by them to monitor progress and take action where necessary to improve outcomes and secure value for money in the use of resources.
4. As part of this work, Audit Wales reviewed corporate documents and held interviews with the Cabinet Member, Director and senior officers with responsibility for the Council's performance management arrangements.
5. A report was issued by Audit Wales in November 2023. Further details of the audit questions and audit criteria used by Audit Wales are set out in Appendix 1 to the Audit Wales report (**Appendix A**).

## Issues

6. Overall, the Audit Wales report found that: *“the Council’s performance information does not consistently enable senior leaders to have a full understanding of the service user perspective but provides information to help senior leaders understand the outcomes of the Council’s activities”*.
7. This assessment is based on the following key findings set out within the Audit Wales report:
  - *“The performance information provided to senior leaders to help them understand the perspective of service users does not consistently cover all service areas”*
  - *“The performance reports to senior leaders provide a balance of output and outcome focused information, although the large volume of information can make it challenging to navigate”*
  - *“The Council has effective arrangements in place to ensure the accuracy of the performance information it provides to senior leaders regarding the service user perspective and outcomes”*
  - *“The Council uses its performance information to help it achieve its intended outcomes”*
  - *“The Council is planning to review the effectiveness of its own arrangements but does not routinely seek to learn from other organisations about gathering the service user perspective”*
8. The Audit Wales report makes just one recommendation. This recommends that the Council should strengthen the information that is provided to senior leaders about the perspective of the service user to enable them to understand how well services and policies are meeting the needs of service users. The organisational response to this recommendation is set out in **Appendix B** to this report.
9. As part of consideration of this agenda item, the Governance and Audit Committee will receive a verbal overview of the scope and findings of the report from Audit Wales officials. Council officers will also be asked to respond verbally setting out the organisation’s response to the report’s findings and recommendation.

## Legal Implications

10. The Audit Wales Report was produced under section 17 of the Public Audit (Wales) Act 2004 and section 15 of the Well-being of Future Generations (Wales) Act 2015. It is for the Committee to note and consider the contents of the Report and its recommendation. There are no other legal implications arising from this Report.

## Financial Implications

11. There are no direct financial implications arising from this report.

## **RECOMMENDATION**

The Committee is recommended to note and consider the contents of the report by Audit Wales.

**Gareth Newell**  
**Head of Performance & Partnerships**  
17 January 2024

The following appendices are attached to this report:

**Appendix A:** Audit Wales Report – Use of performance information: service user perspective and outcomes – City of Cardiff Council (November 2023)

**Appendix B:** Organisational Response

This page is intentionally left blank



## Use of performance information: service user perspective and outcomes – City of Cardiff Council

Audit year: 2022-23

Date issued: November 2023

Document reference: 3936A2023

This document has been prepared as part of work performed in accordance with statutory functions.

In the event of receiving a request for information to which this document may be relevant, attention is drawn to the Code of Practice issued under section 45 of the Freedom of Information Act 2000. The section 45 code sets out the practice in the handling of requests that is expected of public authorities, including consultation with relevant third parties. In relation to this document, the Auditor General for Wales and the Wales Audit Office are relevant third parties. Any enquiries regarding disclosure or re-use of this document should be sent to Audit Wales at [infoofficer@audit.wales](mailto:infoofficer@audit.wales).

We welcome correspondence and telephone calls in Welsh and English. Corresponding in Welsh will not lead to delay. Rydym yn croesawu gohebiaeth a galwadau ffôn yn Gymraeg a Saesneg. Ni fydd gohebu yn Gymraeg yn arwain at oedi.

Mae'r ddogfen hon hefyd ar gael yn Gymraeg. This document is also available in Welsh

# Contents

Repoer summary	4
What we looked at – the scope of this audit	4
Why we undertook this audit	5
The Council's performance reporting arrangements	5
What we found	6
The Council's performance information does not consistently enable senior leaders to have a full understanding of the service user perspective, but provides information to help senior leaders understand the outcomes of the Council's activities.	6
Recommendation	8
Appendices	
Appendix 1: Key questions and what we looked for	9

## Report summary

- 1 We considered the service user perspective and outcome information provided to senior officers and senior elected members (senior leaders), and how this information is used.
- 2 Overall, we found that the Council's performance information does not consistently enable senior leaders to have a full understanding of the service user perspective, but provides information to help senior leaders understand the outcomes of the Council's activities.
- 3 We have made one recommendation to strengthen the performance information given to senior leaders.
- 4 Our findings are based upon fieldwork we did during May 2023.

## What we looked at – the scope of this audit

- 5 We focused on the performance information provided to senior officers and senior elected members (senior leaders) about service user perspective and outcomes, and how this information is used. We did not undertake a full review of the Council's performance management arrangements or an in-depth review of the quality of the data that the Council collects. Neither did the review focus on engagement with service users on specific service changes or the development of policies and strategies.
- 6 We have set out our audit questions and audit criteria in **Appendix 1**. The audit criteria essentially sets out what good looks like and what we would expect to find.
- 7 Overall, we were looking for performance information to be shared with senior leaders to help them understand how well services and policies are meeting the needs of service users and how well they are helping the Council to achieve the outcomes it is working towards. We were also looking to see that senior leaders use this information to monitor progress and take action where necessary to improve outcomes.
- 8 This is an important part of arrangements to ensure that councils are securing value for money in the use of their resources. It is also an important way in which the Council can assure itself that it is acting in accordance with the 'involvement' way of working in taking steps to meet its well-being objectives. Without this information, it is difficult to see how senior leaders can understand whether their policies and actions are having the intended impact and make changes where they are not.
- 9 Our findings are based on document reviews and interviews with the Cabinet Member, Director and senior officers with responsibility for the Council's performance management arrangements. The evidence we have used to inform our findings is limited to these sources.

- 10 We set out to answer the question '**Does the Council's performance data enable senior leaders to understand the service user perspective and the outcomes of its activities to effectively manage its performance?**' We did this by exploring the following questions:
- Does the performance information provided to senior leaders include appropriate information on the perspective of service users?
  - Does the performance information provided to senior leaders include appropriate information on the outcomes of the Council's activities?
  - Does the Council have robust arrangements to ensure that the data provided is accurate?
  - Does the Council use the information to help it achieve its outcomes?
  - Does the Council review the effectiveness of its arrangements?

## Why we undertook this audit

- 11 This audit was undertaken to help fulfil the Auditor General's duties under section 17 of the Public Audit (Wales) Act 2004 (the 2004 Act) and section 15 of the Well-being of Future Generations (Wales) Act 2015.
- 12 We sought to:
- gain assurance that the performance information the Council provides to senior officers and elected members enables them to understand the service user perspective and the outcome of its activities;
  - gain assurance that this information forms part of the Council's arrangements to secure value for money in the use of its resources and its application of the sustainable development principle; and
  - identify opportunities for the Council to strengthen its arrangements.

## The Council's performance reporting arrangements

- 13 The Council has various methods of sharing its performance information with senior leaders.
- 14 All performance information relating to the Corporate Plan is updated and added to the Corporate Plan dashboard every three months. The Council's elected members can access the Corporate Plan dashboard at any time. The Corporate Plan dashboard contains a large amount of information for the Council's performance management, reporting and monitoring needs. It enables the reader to filter upon various types of performance information or subject of interest.
- 15 The Council's Cabinet receives reports on the Council's half-year and end of year self-assessment. The reports include information on surveys, citizen feedback and complaints as well as a link to the Corporate Plan dashboard.

- 16 Scrutiny committees also consider the mid-year self-assessment as part of the process of refreshing the Corporate Plan. The Council also has a Performance Panel, which is a sub-committee of the Policy Review and Performance Scrutiny Committee. It meets three times a year to consider the draft corporate plan (in January and February), the Annual Wellbeing report (in June and July) and the Mid-year Performance Assessment (in December). The Panel receives some performance information as part of that process.
- 17 In January and February of each year, the Council convenes thematic challenge sessions, which are attended by the relevant senior officers and Cabinet Members. The purpose of these sessions is to consider progress against each of the Council's Wellbeing Objectives, to assess performance against key indicators and set targets for the financial year ahead.
- 18 In October 2022, the Council published its Annual Wellbeing Report 2021/22, which incorporates its self-assessment as required by the Local Government and Elections (Wales) Act 2021.
- 19 Twice a year, the Children and Young People Scrutiny Committee and the Community and Adult Services Scrutiny Committee receive performance reports on a range of performance indicators in their service area. This is not the case for other scrutiny committees.
- 20 Our review focused on these key performance reporting mechanisms.

## What we found

**The Council's performance information does not consistently enable senior leaders to have a full understanding of the service user perspective, but provides information to help senior leaders understand the outcomes of the Council's activities**

**The performance information provided to senior leaders to help them understand the perspective of service users does not consistently cover all service areas**

- 21 Overall, we found some examples of performance information provided to senior leaders to help them understand the perspective or experience of service users. These include performance measures relating to the customer contact centre, some social services indicators and some information from the Council's annual 'Ask Cardiff' survey. However, the information that senior leaders receive does not consistently cover all service areas of the Council.
- 22 The Council's Annual Wellbeing Report 2021/22 references the consultation and engagement activity that the Council has undertaken throughout the year. But it's

not clear how the Council has used the results of that activity to inform its self-assessment, or to enable senior leaders to understand the service user perspective.

- 23 Therefore, overall, it can be difficult for senior leaders to understand the citizen perception of all Council services and polices.

### **The performance reports to senior leaders provide a balance of output and outcome focused information, although the large volume of information can make it challenging to navigate**

- 24 The performance information provided to senior leaders includes a balance of output and outcome focused information. This can help senior leaders understand the outcomes of its activities.
- 25 However, within the large volume of information contained in the Corporate Dashboard, it can be challenging to understand how individual outcome measures link to the Council's strategic priorities and objectives. This in turn means it can be challenging for senior leaders to assess the Council's progress towards its objectives and understand the impact of individual measures.

### **The Council has effective arrangements in place to ensure the accuracy of the performance information it provides to senior leaders regarding the service user perspective and outcomes**

- 26 The Council has arrangements in place to assure itself about the accuracy of its performance information.
- 27 Officers within services, centrally located Performance and Insight officers, and Directors all have responsibilities to verify the data prior to publication. The Council provided us with documents to substantiate this process. It was also able to provide examples of occasions where they had identified concerns with the accuracy of the data being collected and had worked to address that. For example, the Council commissioned an independent review into the data in a service where there additional assurance was required on data accuracy.

### **The Council uses its performance information to help it achieve its intended outcomes**

- 28 We have already set out that the information the Council collects on the service user perspective does not consistently cover all service areas. However, where the Council does have information on the perspective of service users and outcomes, we found examples of the Council then using this information to make changes. This included an example where the Council had observed a decline in satisfaction data, relating to an increase in antisocial behaviour in the Cowbridge Road area. The Council acted to address this and saw a subsequent improvement in satisfaction rates.

## **The Council is planning to review the effectiveness of its own arrangements but does not routinely seek to learn from other organisations about gathering the service user perspective**

- 29 The Council acknowledges that it could do more to strengthen the link between the information on the service user perspective it collects at a service level and the performance information it regularly reports to its senior leaders. The Council has developed a plan to review its citizen satisfaction data to strengthen the connection between service and corporate level reporting.
- 30 The Council does not compare the type of information it collects or collection methods on service user perspective or outcomes with the information collected by similar organisations. We do not mean comparing performance per se, but to help it learn how other organisations are providing information about service user perspectives and outcomes to help strengthen its own arrangements. This is an important element of arrangements to secure value for money.

## **Recommendation**

### **Exhibit 1: recommendation**

- R1 Information on the perspective of the service user
- the Council should strengthen the information it provides to its senior leaders to enable them to understand how well services and policies are meeting the needs of service users.



# Appendix 1

## Key questions and what we looked for

### Exhibit 2: key questions and what we looked for

The table below sets out the question we sought to answer in carrying out this audit, along with the audit criteria we used to arrive at our findings.

Level 1	
Does the Council's performance data enable senior leaders to understand the service user perspective and the outcomes of its activities to effectively manage its performance?	
Level 2	Audit Criteria <sup>1</sup> (what we are looking for)
2.1 Does the performance information provided to senior leaders include appropriate information on the perspective of service users?	<ul style="list-style-type: none"> <li>• The information is:               <ul style="list-style-type: none"> <li>– relevant to the objectives the Council has set itself;</li> <li>– sufficient to enable an understanding of the service user perspective;</li> <li>– sufficient to provide an understanding of progress towards the outcomes the Council is planning to achieve;</li> <li>– drawn from the diversity of service users including groups who share protected characteristics; and</li> <li>– used to inform comparisons with the performance of similar bodies where relevant.</li> </ul> </li> <li>• The Council has involved service users in determining which information to collect.</li> </ul>
2.2 Does the performance information provided to senior leaders include appropriate information on the outcomes of the Council's activities?	<ul style="list-style-type: none"> <li>• The information draws on a range of evidence sources to provide a holistic view of progress.</li> <li>• The information enables senior leaders to monitor progress over the short, medium and long term.</li> <li>• The information enables senior leaders to monitor the delivery of outcomes that cover multiple service areas and/or organisations.</li> </ul>

<sup>1</sup> Our audit criteria have been informed by our cumulative knowledge of previous audit work, as well as the question hierarchy and positive indicators we have developed to support our sustainable development principle examinations.

## Level 1

Does the Council's performance data enable senior leaders to understand the service user perspective and the outcomes of its activities to effectively manage its performance?

## Level 2

### Audit Criteria<sup>1</sup> (what we are looking for)

2.3 Does the Council have robust arrangements to ensure that the data provided is accurate?

- The Council has clear arrangements to check the quality and accuracy of the data it provides to senior leaders.
- Where weaknesses in data quality are identified, the Council addresses them.

2.4 Does the Council use the information to help it achieve its outcomes?

- Where poor performance is identified, the Council uses the information to make changes/interventions.
- There is evidence of the Council improving its progress towards its outcomes as a result of interventions.

2.5 Does the Council review the effectiveness of its arrangements?

- The Council reviews the information provided to senior leaders to ensure it is appropriate and relevant.
- The Council compares the information it collects with the information collected by similar organisations to identify opportunities to strengthen its arrangements.





Audit Wales

1 Capital Quarter

Cardiff CF10 4BZ

Tel: 029 2032 0500

Fax: 029 2032 0600

Textphone: 029 2032 0660

E-mail: [info@audit.wales](mailto:info@audit.wales)

Website: [www.audit.wales](http://www.audit.wales)

We welcome correspondence and telephone calls in Welsh and English.  
Rydym yn croesawu gohebiaeth a galwadau ffôn yn Gymraeg a Saesneg.

## APPENDIX B

### Organisational response

**Report title:** Use of Performance Information: Service user perspective and outcomes – City of Cardiff Council

**Completion date:** January 2024

**Document reference:** 3936A2023

Page 161

Ref	Recommendation	Organisational response Please set out here relevant commentary on the planned actions in response to the recommendations	Completion date Please set out by when the planned actions will be complete	Responsible officer (title)
R1	<p>Information on the perspective of the service user</p> <ul style="list-style-type: none"> <li>the Council should strengthen the information it provides to its senior leaders to enable them to understand how well services and policies are meeting the needs of service users.</li> </ul>	<p><b>The Council will strengthen links between its service user perspective data and the Performance Framework, in line with commitments in the Participation Strategy, Including:</b></p> <ul style="list-style-type: none"> <li><b>Reviewing the citizen insight KPIs in the Corporate Plan.</b></li> <li><b>Including citizen insight KPIs in all Directorate Delivery Plans.</b></li> <li><b>Review all Wales and Core City metrics to inform the above.</b></li> </ul>	April 2024	Gareth Newell (Head of Performance and Partnerships)

This page is intentionally left blank

**GOVERNANCE & AUDIT COMMITTEE: 23<sup>rd</sup> January 2024**

---

**“Digital Strategy Review: Cardiff Council”  
Report issued November 2023 by Audit Wales****AGENDA ITEM: 7.3****REPORT OF THE CHIEF DIGITAL OFFICER**

---

**Reason for this Report**

1. The Governance and Audit Committee’s Terms of Reference requires that Members:
  - Consider the Council’s framework of assurance and ensure that it adequately addresses the risk and priorities of the Council.
  - Consider the Council’s arrangements to secure value for money and review assurances and assessments on the effectiveness of these arrangements.
  - Consider specific reports as agreed with the external auditors.
  - Comment on the scope and depth of external audit work and to ensure it gives value for money.
  - Consider commissioning additional work from internal and external audit.
2. This report has been prepared to provide Governance and Audit Committee Members with an overview of the findings of the report of the Auditor General for Wales.

**Background**

3. Audit Wales reviewed the “Council’s strategic approach to digital, and specifically the extent to which this has been developed in accordance with the sustainable development principle; and that it will help to secure value for money in the use of the Council’s resources.”
4. The Project Brief was provided by Audit Wales in April 2023 and is included within Appendix A to this report.
5. The Project Brief advised that:
  - Digital is key to delivering a wide range of council services in a more economic, efficient and effective way. It follows that it is also an important means of councils delivering their wellbeing objectives and carrying out sustainable development.
  - Digital strategies also have a significant impact on how people access services, whether through improved access to services or the potential for ‘digital exclusion’

where services are 'digitised' but as a consequence some members of the public may be unable to access them.

- This work also builds on our previous 'springing forward' review that looked at the topics of assets and workforce that we undertook during 2021-22. We are undertaking this audit at each of the 22 principal councils in Wales.

## **Audit Objectives**

6. The objectives for the audit were to:

- Provide assurance that the councils' digital strategies will help to deliver well-being objectives in a way that secures value for money in the use of resources;
- Provide assurance that councils are acting in accordance with the sustainable development principal in the design of their digital strategies;
- Explain how councils are using/planning to use digital technology to meet people's needs and deliver better outcomes; and
- Inspire and empower councils and other public sector bodies by identifying and sharing examples of notable practice/approaches where relevant

## **Issues**

## **Findings**

7. The findings of the audit are based on document reviews and interviews with a sample of cabinet Members and senior officers. The evidence used to inform the findings is limited to these sources. Audit Wales undertook this work during April to July 2023, and the Digital Strategy Review Report is included within Appendix B.

## **Identified Areas of good practice**

- The digital strategy clearly articulates its approach and seeks to deliver benefits by exploring new ways of working, increasing service accessibility and improving customer service
- The Council has drawn on a wide range of information (internal and external) to develop the strategy. Data is used to understand current demographic trends to help target those residents in need of support
- The council scans for future technologies which may help in advancing the strategy
- The council also uses internal data from across the organisation to identify how citizens access services across the many channels available
- The digital strategy is integrated with key priorities such as Hybrid working and the One Planet strategy and aligns with the Council's wellbeing objectives
- The council works with a wide range of partners through its approach to digital e.g agile workstations with EME services, joint housing allocations scheme, social landlords and initiatives in higher education
- There are positive examples where the council allocates resources to secure better outcomes over the long term, for example through the single view of the child project
- The Council is sharing lessons learnt with other councils



## Key findings

- The Council has a mature strategic approach to digital, but this lacks clear timebound objectives. It is planning over an appropriate timescale based on an analysis of current and future trends but has not clearly set out the anticipated short- or long-term impacts of its digital strategy. In the absence of short medium- and long-term objectives for its digital strategy it is difficult for the Council to monitor and evaluate progress against its digital strategy over the medium and longer-term.
- The Council has not directly engaged with its citizens in developing its digital strategy. Not involving the full diversity of those with an interest in the development and delivery of the digital strategy risks the design of approaches that do not meet the needs of citizens nor will deliver value for money.
- The delivery of the strategy is monitored on a project-by-project basis. As such the resource implications, service user satisfaction and impacts have not been analysed and collated to provide effective corporate oversight of the strategy and its achievements. This makes it difficult for the Council to monitor progress in delivering the strategy as well as understanding the overall impact and value for money of the Council's strategic approach to digital.

## Recommendations

### Strengthening the evidence base

**R1** To help ensure that its next digital strategy is well informed and that its resources are effectively targeted, in developing its strategy the Council should draw on evidence from a wider range of sources, including greater involvement of stakeholders with an interest in the digital strategy.

### Identifying resource implications

**R2** To help ensure that its next digital strategy is deliverable and to help monitor value for money the Council should identify the short and long-term resource implications of delivering it together with any intended efficiency savings.

### Arrangements to improve corporate oversight

**R3** To enable better corporate oversight and assessment of value for money from its next digital strategy, the Council should strengthen its arrangements for monitoring both progress in delivering the strategy and its overall impact over the short, medium and longer term.

## Management Response

8. The following paragraphs set out the considered management response in order to address the recommendations arising from the report.

### R1 Strengthening the evidence base

In the development of the next digital strategy Cardiff will be completing the following activities

- Engaging through consultation with internal stakeholders to identify digital activities planned or taking place to identify the following:

- Drivers for change – Efficiency, Process improvements or better outcomes for citizens.
- Current and planned resource levels with associated funding
- What additional support would be required – training, project management, data collection and analysis etc
- The organisation will continue its work in engaging with Citizens to help shape the strategy's priorities:
  - Analyse the feedback from the latest “Digital” survey to understand the current habits and expectations from Citizens
  - Use the Digital Exclusion Risk Index to help identify where citizen may need the greatest assistance to access the digital offer
  - Consult with the City on the proposals in the new strategy to ensure that it will meet the needs of the city and deliver value.

## **R2 - Identifying resource implications**

Once the internal consultation is completed Cardiff will be better placed to identify the basis for its digital activities. We will identify what resources are currently in place, the cost of these roles and skills associated. We will look to formalise the training plans for staff to ensure they are sufficiently competent in delivering digital projects both through extending agile training but also leaning on DDaT roles and skills base to ensure suitably skilled staff are employed.

Plans will be monitored financially over the short and long term to ensure efficiency savings as a result of the work are measured and checked against the business cases upon which they are based.

A digital leads network will be created to ensure that any opportunities to share resources and skills are maximised.

## **R3 Arrangements to improve corporate oversight**

Once information gathering through directorates is complete the activities will be mapped and tracked. Updates on progress will be reviewed through the existing Digital Board structure using the existing Portfolio, Programme and Project management database within the organisation.

Projects will be reviewed for their measures of success both against achievability and to ensure that they are delivering within the expected timeframes.

## **Legal Implications**

9. There are no direct legal implications arising from this report.

## **Financial Implications**

10. There are no direct financial implications arising from this report. The next Digital Strategy will need to be supported by the required budget provision, to include identified efficiency savings.

## **RECOMMENDATIONS**

11. That the Committee notes and considers the content of the report.

Isabelle Bignall – Chief Digital Officer

The following are attached:

- Appendix A: Project Brief (Draft) – Digital Strategy Review – Cardiff Council (Audit Wales)
- Appendix B: Digital Strategy Review – Cardiff Council (Audit Wales)
- Appendix C: Organisational Response Form – Cardiff Council (Audit Wales / Cardiff Council)

This page is intentionally left blank

## Project Brief – Digital Strategy Review – City of Cardiff County Council

Audit year: 2022-23

Date issued: April 2023

Document reference: 3595A2023

This document has been prepared for the internal use of the twenty two principal councils in Wales in accordance with statutory functions under section 17 of the Public Audit (Wales) Act 2004 (the 2004 Act) and section 15 of the Well-being of Future Generations (Wales) Act 2015.

No liability is accepted by the Auditor General or the staff of the Wales Audit Office in relation to any member, director, officer or other employee in their individual capacity, or to any third party in respect of this report.

In the event of receiving a request for information to which this document may be relevant, attention is drawn to the Code of Practice issued under section 45 of the Freedom of Information Act 2000. The section 45 Code sets out the practice in the handling of requests that is expected of public authorities, including consultation with relevant third parties. In relation to this document, the Auditor General for Wales and Wales Audit Office are relevant third parties. Any enquiries regarding disclosure or re-use of this document should be sent to Audit Wales at [infoofficer@audit.wales](mailto:infoofficer@audit.wales).

We welcome correspondence and telephone calls in Welsh and English. Corresponding in Welsh will not lead to delay. Rydym yn croesawu gohebiaeth a galwadau ffôn yn Gymraeg a Saesneg. Ni fydd gohebu yn Gymraeg yn arwain at oedi.

Mae'r ddogfen hon hefyd ar gael yn Gymraeg. This document is also available in Welsh.

# Contents

## Project Brief – Digital Strategy Review

Background.....	4
Legal basis.....	4
Audit objective .....	4
Audit questions .....	4
Audit scope .....	5
Audit criteria.....	5
Audit methods.....	5
Output.....	5
Timetable.....	5
Audit Wales contacts .....	5
Fieldwork schedule.....	6
Document request .....	6
Interviews.....	7
Appendix 1 - Audit questions and criteria.....	8
Appendix 2 - Fair processing notice .....	13

# Project brief

## Background

- 1 Digital is key to delivering a wide range of council services in a more economic, efficient and effective way. It follows that it is also an important means of councils delivering their wellbeing objectives and carrying out sustainable development.
- 2 Digital strategies also have a significant impact on how people access services, whether through improved access to services or the potential for 'digital exclusion' where services are 'digitised' but as a consequence some members of the public may be unable to access them.
- 3 This work also builds on our previous 'springing forward' review that looked at the topics of assets and workforce that we undertook during 2021-22. We are undertaking this audit at each of the 22 principal councils in Wales.

## Legal basis

- 4 We are carrying out this audit under the duties contained within:
  - section 17 of the Public Audit (Wales) Act 2004 (the 2004 Act) to help enable the Auditor General to be satisfied (or not) that the Council has put in place proper arrangements to secure value for money in the use of its resources and;
  - section 15 of the Well-being of Future Generations (Wales) Act 2015 to help enable the Auditor General to assess the extent to which the Council is acting in accordance with the sustainable development principle in taking steps to meet its well-being objectives.

## Audit objectives

- 5 Our objectives for this audit are to:
  - provide assurance that the councils' digital strategies will help to deliver well-being objectives in a way that secures value for money in the use of resources;
  - provide assurance that councils are acting in accordance with the sustainable development principal in the design of their digital strategies;
  - explain how councils are using/planning to use digital technology to meet people's needs and deliver better outcomes; and
  - inspire and empower councils and other public sector bodies by identifying and sharing examples of notable practice/approaches where relevant

## Audit questions

- 6 **Appendix 1** contains the audit questions and audit criteria.



## Audit scope

- 7 The audit will cover the Council’s strategic approach to digital, and specifically the extent to which this has been developed in accordance with the sustainable development principle; and that it will help to secure value for money in the use of the council’s resources.

## Audit criteria

- 8 The proposed audit will use the audit criteria set out in Appendix 1, which also shows how the criteria relate to the audit questions. This has been informed by our cumulative knowledge as well as the question hierarchy and positive indicators we have developed to support our sustainable development principle examinations

## Audit methods

- 9 The audit will be informed by interviews with senior officers and cabinet members responsible for the development of the council’s digital strategy, as well as a sample of cabinet members and senior officers with responsible for key portfolios/service areas impacted by the digital strategy. We will also review the documents set out in Exhibit 2 below.

## Output

- 10 The audit will produce the following output(s):
- Local report for each principal council
  - National summary report
- 11 We also intend that our findings will help inform a Good Practice Exchange Event on the topic of digital in the autumn of 2023.

## Timetable

- 12 **Exhibit 1** shows the high level timetable of the main audit stages.

### Exhibit 1: audit timetable

Stage	Date
Issue project brief	08 March 2023
Issue draft local report	19/06/2023
Issue final local report	17/07/2023
Publish national summary report	31/10/2023

## Audit Wales contacts

- 13 **Exhibit 2** sets out the Audit Wales team that will be working on this audit.

## Exhibit 2: Audit Wales contacts

Name	Contact details
Gary Emery – Audit Director	Gary.Emery@audit.wales
Tim Buckle – Auditor Manager	<a href="mailto:Timothy.Buckle@audit.wales">Timothy.Buckle@audit.wales</a>
Samantha Clements – Performance Audit Lead	<a href="mailto:Samantha.Clements@audit.wales">Samantha.Clements@audit.wales</a>

## Fieldwork schedule

- 14 We will conduct our fieldwork in line with the organisation’s stated language preference. We will make every reasonable effort to accommodate language preferences of individuals during the audit, if we receive these at the point of setting up fieldwork.

## Document request

- 15 We will undertake a review of the documents listed below. The list is not exhaustive and we may request additional documents during the course of the project. Where documents in the list below are publicly available please direct us to their online location. Where we already have copies of the documents, we will confirm this at the project set up meeting. Also, we would be grateful if you could provide us with any additional documents that you feel may be relevant to this work.

## Exhibit 3: initial document request

Document title
<ul style="list-style-type: none"><li>• Digital strategy or equivalent</li><li>• Evidence base used to inform the digital strategy</li><li>• Evidence of extent and methods of involvement activity in developing the digital strategy including any evidence of stakeholder mapping</li><li>• Evidence of how the digital strategy is communicated within the council and to partners</li><li>• Implementation plans for the digital strategy</li><li>• Service plans that relate to key elements of the digital strategy</li><li>• Savings plans that relate to the digital strategy</li><li>• Key corporate plans and strategies – including:<ul style="list-style-type: none"><li>– asset management plan,</li><li>– workforce plan</li></ul></li></ul>

## Document title

- well-being statement
- carbon reduction plan
- learning and development plans
- medium term financial plan
- Public Services Board Well-being Plan
- The Council's Annual Self-Assessment Report
- Monitoring reports or equivalent in relation to the digital strategy
- Budget monitoring reports including service area budget reports that relate to key elements of the digital strategy
- Reports setting out the details of any partnerships relevant to the delivery of the digital strategy and/or reports of any reviews of these partnerships

## Interviews

### 16 Exhibit 3: interviewees (via Microsoft Teams)

Name	Title
Isabelle Bignall and Emlyn Nash	Chief Digital Officer and Digital Delivery Manager
Matthew Wakelam and Cllr Caro Wild	Assistant Director Street Scene and Relevant Cabinet Member
Gareth Newell	Head of Policy Partnerships and Performance
Isabelle Bignall and Cllr Chris Weaver	Chief Digital Officer and Relevant cabinet member

# Appendix 1

## Audit questions and criteria

Main audit question: **In developing its digital strategy has the Council acted in accordance with the sustainable development principle and put in place proper arrangements to secure value for money in the use of its resources?**

L2 questions	L3 questions	Criteria
1. Is the Council's digital strategy informed by a good understanding of current and future trends?	1.1 Is there is a thorough understanding of the 'as is' (i.e. current demand/ issues to be addressed) and the reasons why/ underlying causes?	<ul style="list-style-type: none"> <li>• The Council has drawn on a broad range of information from internal and external sources to develop a thorough understanding of the 'as is' and how it is likely to change. This includes information (including data) relating to:               <ul style="list-style-type: none"> <li>– service sustainability/ resilience and resourcing challenges,</li> <li>– the needs of citizens and communities.</li> <li>– the underlying causes of current demand/issues to be addressed.</li> <li>– analysis of future trends and how they might impact. E.g. social, economic/political, environmental, cultural or technological. They might include known trends e.g. ageing population, depleting natural resources and particularly</li> </ul> </li> </ul>

	<p>1.2 Is there a thorough understanding of the long-term factors that will impact and the challenges and opportunities that may result (e.g. risks and opportunities)?</p>	<p>technological advances They might also include those with a higher level of uncertainty e.g. jobs and skills needed in the future.</p> <ul style="list-style-type: none"> <li>• The analysis of the ‘as is’ and how it is likely to change is well informed by involvement activity, as appropriate, that reflects recognised good practice (e.g. <a href="#">National Principles for Public Engagement in Wales</a>, Future Generations Commissioner for Wales advice and guidance).</li> <li>• The Council uses its evidence base effectively to: <ul style="list-style-type: none"> <li>– Identify actions in its strategic approach to digital that are likely to be most effective and why, including how they could address the root causes of problems.</li> <li>– Inform decisions around its use of digital technology that seek to balance the need to meet short- and longer-term objectives.</li> </ul> </li> </ul>
<p>2. Does the Council have a clear vision of what it wants to achieve through the use of digital technology?</p>	<p>2.1 Is the council planning over an appropriate timescale?</p>	<ul style="list-style-type: none"> <li>• The Council has considered what long term means in planning its approach to digital – i.e. how far ahead it can/should plan and why (at least 10 years with consideration of longer-term trends as appropriate)</li> <li>• The Council has considered how actions can deliver the best impact over that timeframe in terms of outcomes and most effective use of resources. This could include consideration of appropriate intervention points linked to the Commissioner’s definition of prevention. (click on the following link for details: <a href="#">Taking account of the Well-being of Future Generations Act in the budget process – The Future Generations Commissioner for Wales</a>)</li> <li>• The Council has set out measures for its digital strategy that reflect short and long-term impacts and value for money, with milestones that reflect progress as appropriate</li> <li>• The Council has set out how its digital strategy will be resourced over the longer term as far as is practical (See also criteria relating to integration)</li> </ul>

	<p>2.2 Has the Council thought about the wider impacts its digital strategy could have, including;</p> <ul style="list-style-type: none"> <li>• how it could contribute to each of the seven national well-being goals?</li> <li>• how delivery will impact on the other things it is trying to achieve (i.e. its well-being objectives and wider priorities)?</li> <li>• how delivery will impact on other what other public bodies are trying to achieve (i.e. their well-being objectives)?</li> </ul>	<ul style="list-style-type: none"> <li>• The Council has considered how its digital strategy can make a contribution across the well-being goals.</li> <li>• Staff developing the digital strategy understand what colleagues and partners do and how their work relates, and have sought to integrate their work with that of their colleagues from across the Council and with partner organisations</li> <li>• Integration is evident in the alignment of the digital strategy with other key corporate strategies and service plans. For example medium term financial plan, workforce plan, asset management strategies, well-being statement and carbon reduction plans.</li> <li>• The digital strategy is aligned with other strategic intents such as:             <ul style="list-style-type: none"> <li>– customer experience,</li> <li>– management of demand/ reductions in demand failure and prevention</li> <li>– design and implementation of new service delivery models.</li> </ul> </li> <li>• The council’s digital strategy aligns with the plans/strategies of local and national partners including the Welsh Government’s Digital Strategy for Wales <a href="#">Digital strategy   GOV.WALES</a> and well-being plans.</li> </ul>
	<p>2.3 Is there a wide and common understanding of what the council is trying to achieve?</p>	<ul style="list-style-type: none"> <li>• Councillors and senior officers responsible for implementing the digital strategy have a common and clear understanding of what the Council is trying to achieve and the intended impact on service delivery</li> <li>• The Council’s digital strategy is clearly communicated to staff and partners who may help deliver it</li> </ul>
<p>3. Is the council working effectively with the right people and partners to design and deliver its digital strategy</p>	<p>3.1 Has the Council identified who it needs to involve?</p>	<ul style="list-style-type: none"> <li>• The Council has a good understanding of who will be directly and indirectly affected by its digital strategy and who it needs to involve.</li> <li>• The Council has effectively involved the full diversity of views in developing its digital strategy, including from non-traditional sources and from those it may have previously failed to reach.</li> </ul>

	<p>3.2 Is the council effectively involving the full diversity of people affected by its digital strategy?</p>	<ul style="list-style-type: none"> <li>• The Council has provided genuine opportunities for people to influence design and delivery of its digital strategy from an early stage, including representatives of groups who share protected characteristics.</li> <li>• The Council has used the results of involvement to shape the design and delivery of its digital strategy</li> </ul>
	<p>3.3 Is the Council collaborating effectively with the right partners?</p>	<ul style="list-style-type: none"> <li>• The Council is collaborating to ensure it delivers better outcomes and value for money through its digital strategy and has put appropriate arrangements in place to support this, for example for;             <ul style="list-style-type: none"> <li>– sharing or pooling expertise and resources</li> <li>– sharing information</li> <li>– ensuring effective monitoring, evaluation and accountability including consideration of value for money</li> </ul> </li> </ul>
<p>4. Has the council resourced delivery of its digital strategy so it can deliver long-term/ preventative benefits?</p>	<p>4.1 Does the Council understand long-term resource implications?</p>	<ul style="list-style-type: none"> <li>• The Council has assessed the costs and benefits of using digital technology to invest in long-term, preventative approaches and the cost (both financial and in terms of outcomes) of not doing so.</li> <li>• The Council has thought about the resources it will need to deliver its digital strategy over the medium and longer term (whole life costs) and how it could manage risks/ meet those costs including for example planned ‘invest to save’ initiatives and managed reductions in technical debt.</li> <li>• The Council has calculated and set out any savings it intends to make through implementing its digital strategy</li> </ul>
	<p>4.2 Does the Council allocate resources to deliver better outcomes over the long-term?</p>	<ul style="list-style-type: none"> <li>• Action (inc. preventative action) that is likely to contribute to better outcomes and/or use of resources over the longer term is promoted and supported, even:             <ul style="list-style-type: none"> <li>– where this may limit the ability to meet some short-term needs.</li> <li>– where the benefits are likely to be accrued by or attributed to another organisation.</li> </ul> </li> </ul>

<p>5. Is the Council monitoring and reviewing progress?</p>	<p>5.1 Is the Council monitoring and reviewing progress towards, short, medium- and longer-term objectives?</p>	<ul style="list-style-type: none"> <li>• The Council monitors the costs and benefits of delivering its digital strategy from a value for money perspective</li> <li>• The Council is measuring the wider contribution the digital strategy is making across its own/ partnership objectives</li> <li>• Progress is measured against short, medium and long-term objectives</li> </ul>
<p>6. Is the Council learning lessons from how it works?</p>	<p>6.1 Does the Council review the effectiveness of its digital strategy?</p>	<ul style="list-style-type: none"> <li>• The Council regularly reviews the effectiveness of its digital strategy including:               <ul style="list-style-type: none"> <li>- effectiveness of its collaborative activity</li> <li>- effectiveness of its involvement activity, including the impact of the strategy on service users including those who are digitally excluded</li> <li>- the impact of the strategy on those who share protected characteristics</li> <li>- the economy, efficiency and effectiveness of the digital strategy overall in helping the council to achieve its strategic objectives.</li> </ul> </li> <li>• The Council has reviewed lessons learned from its response to the pandemic and is applying this learning to its digital strategy</li> </ul>
	<p>6.2 Does the Council share lessons learned from its approach to its digital strategy?</p>	<ul style="list-style-type: none"> <li>• The Council shares and applies any lessons learned from the development and delivery of its digital strategy widely across the organisation, and with partners where relevant</li> </ul>



# Appendix 2

## Fair processing notice

**Date issued:** August 2021

### **Auditor General for Wales – Privacy Notice**

This privacy notice tells you about how the Auditor General for Wales and staff of the Wales Audit Office (WAO) process personal information collected in connection with our work.

### **Who we are and what we do**

The Auditor General for Wales' work includes examining how public bodies manage and spend public money, and the WAO provides the staff and resources to enable him to carry out his work. "Audit Wales" is a trademark of the Wales Audit Office, and is the umbrella identity of the Auditor General for Wales and the Wales Audit Office.

### **Data Protection Officer (DPO)**

Our DPO can be contacted by telephone on 029 2032 0500 or by email at [infoofficer@audit.wales](mailto:infoofficer@audit.wales)

### **The relevant laws**

We process your personal data in accordance with data protection legislation, including the Data Protection Act 2018 (DPA) and the UK General Data Protection Regulation (GDPR). Our lawful bases for processing are the powers and duties set out in the Public

Audit (Wales) Acts 2004 and 2013, the Government of Wales Acts 1998 and 2006, the Local Government (Wales) Measure 2009, the Local Government & Elections (Wales) Act 2021 and the Well-being of Future Generations (Wales) Act 2015. Depending on the particular power or function, these statutory bases fall with Article 6(c) and (e) of the UK GDPR—processing necessary for compliance with a legal obligation, for the performance of a task carried out in the public interest or in the exercise of official authority.

### **Who will see the data?**

The Auditor General and relevant WAO staff, such as the study team, will have access to the information you provide.

Our published report may include some of your information, but we will contact you before any publication of information that identifies you—see also "your rights" below.

We may share information with:

- a) Senior management at the audited body(ies) as far as this is necessary for exercising our powers and duties;

- b) Certain other public bodies/ public service review bodies such as the Office of the Future Generations Commissioner, Care Inspectorate Wales (Welsh Ministers), Estyn and the Public Services Ombudsman for Wales, where the law permits or requires this, such as under section 15 of the Well-being of Future Generations (Wales) Act 2015.

## **How long we keep the data**

We will generally keep your data for 6 years, though this may increase to 25 years if it supports a published report—we will contact you before any publication of information that identifies you—see also “your rights” below. After 25 years, the records are either transferred to the UK National Archive or securely destroyed. In practice, very little personal information is retained beyond 6 years.

## **Our rights**

The Auditor General has rights to information, explanation and assistance under paragraph 17 of schedule 8 Government of Wales Act 2006, section 52 Public Audit (Wales) Act 2004, section 26 of the Local Government (Wales) Measure 2009 and section 98 of the Local Government & Elections (Wales) Act 2021. It may be a criminal offence, punishable by a fine, for a person to fail to provide information.

## **Your rights**

You have rights to ask for a copy of the current personal information held about you and to object to data processing that causes unwarranted and substantial damage and distress.

To obtain a copy of the personal information we hold about you or discuss any objections or concerns, please write to The Information Officer, Wales Audit Office, 24 Cathedral Road, Cardiff, CF11 9LJ or email [infoofficer@audit.wales](mailto:infoofficer@audit.wales). You can also contact our Data Protection Officer at this address.

## **Information Commissioner’s Office**

To obtain further information about data protection law or to complain to complain about how we are handling your personal data, you may contact the Information Commissioner at: Information Commissioner’s Office, Wycliffe House, Water Lane, Wilmslow, Cheshire, SK9 5AF, or by email at [casework@ico.gsi.gov.uk](mailto:casework@ico.gsi.gov.uk) or by telephone 01625 545745.





Audit Wales

1 Capital Quarter  
Cardiff CF10 4BZ

Tel: 029 2032 0500

Fax: 029 2032 0600

Textphone: 029 2032 0660

E-mail: [info@audit.wales](mailto:info@audit.wales)

Website: [www.audit.wales](http://www.audit.wales)

We welcome correspondence and telephone calls in Welsh and English.  
Rydym yn croesawu gohebiaeth a galwadau ffôn yn Gymraeg a Saesneg.

## Digital Strategy Review – Cardiff Council

Audit year: 2022-23

Date issued: December 2023

Document reference: 3974A2023

This document has been prepared as part of work performed in accordance with statutory functions.

In the event of receiving a request for information to which this document may be relevant, attention is drawn to the Code of Practice issued under section 45 of the Freedom of Information Act 2000. The section 45 code sets out the practice in the handling of requests that is expected of public authorities, including consultation with relevant third parties. In relation to this document, the Auditor General for Wales and the Wales Audit Office are relevant third parties. Any enquiries regarding disclosure or re-use of this document should be sent to Audit Wales at [infoofficer@audit.wales](mailto:infoofficer@audit.wales).

We welcome correspondence and telephone calls in Welsh and English. Corresponding in Welsh will not lead to delay. Rydym yn croesawu gohebiaeth a galwadau ffôn yn Gymraeg a Saesneg. Ni fydd gohebu yn Gymraeg yn arwain at oedi.

Mae'r ddogfen hon hefyd ar gael yn Gymraeg. This document is also available in Welsh.

# Contents

Digital strategy review	
Report summary	4
Detailed report	
What we looked at and why – the scope of this audit	6
What we found - The Council has a mature strategic approach to digital, but this lacks clear timebound objectives informed by service users to enable corporate oversight of its impact	8
Appendices	
Appendix 1: key questions and audit criteria	12

# Digital strategy review

## Report summary

### Exhibit 1: Report Summary

The exhibit below summarises the reason why we undertook this audit, our key findings and recommendations for the Council.

#### Why a strategic approach to digital is important.

- 1 Digital technology is key to delivering a wide range of council services in a more economic, efficient and effective way, it is also an important means for councils to deliver their wellbeing objectives and carry out sustainable development.
- 2 Having a clearly articulated strategic approach to digital can bring several benefits such as:
  - establishing a common vision for use of digital and the intended outcomes for local communities linked to the council's strategic objectives.
  - helping to ensure that councils use of digital technology is aligned with their key strategic objectives and other plans and strategies and is informed by a good understanding of current and future trends.
  - reducing the risk of duplication both within councils and with partners.
  - consideration of coordinated resourcing of digital over the short, medium and longer term
  - providing a framework against which to monitor progress over the short, long and medium term

#### The focus of our audit

- 3 We looked at the extent to which the Council's strategic approach to digital has been developed in accordance with the sustainable development principle and whether it will help to secure value for money in the use of the Council's resources.

#### Our key findings

- 4 The Council has a mature strategic approach to digital, but this lacks clear timebound objectives. It is planning over an appropriate timescale based on an analysis of current and future trends but has not clearly set



out the anticipated short- or long-term impacts of its digital strategy. In the absence of short medium- and long-term objectives for its digital strategy it is difficult for the Council to monitor and evaluate progress against its digital strategy over the medium and longer-term.

- 5 The Council has not directly engaged with its citizens in developing its digital strategy. Not involving the full diversity of those with an interest in the development and delivery of the digital strategy risks the design of approaches that do not meet the needs of citizens nor will deliver value for money.
- 6 The delivery of the strategy is monitored on a project-by-project basis. As such the resource implications, service user satisfaction and impacts have not been analysed and collated to provide effective corporate oversight of the strategy and its achievements. This makes it difficult for the Council to monitor progress in delivering the strategy as well as understanding the overall impact and value for money of the Council's strategic approach to digital.

---

## **Our recommendations for the Council**

### **Strengthening the evidence base**

- R1 To help ensure that its next digital strategy is well informed and that its resources are effectively targeted, in developing its strategy the Council should draw on evidence from a wider range of sources, including greater involvement of stakeholders with an interest in the digital strategy.

---

### **Identifying resource implications**

- R2 To help ensure that its next digital strategy is deliverable and to help monitor value for money the Council should identify the short and long-term resource implications of delivering it together with any intended efficiency savings.

---

### **Arrangements to improve corporate oversight.**

- R3 To enable better corporate oversight and assessment of value for money from its next digital strategy, the Council should strengthen its arrangements for monitoring both progress in delivering the strategy and its overall impact over the short, medium and longer term.

## Detailed report

### What we looked at – the scope of this audit

- 1 We reviewed the Council's strategic approach to digital, and specifically the extent to which this has been developed in accordance with the sustainable development principle; and that it will help to secure value for money in the use of the Council's resources.
- 2 Our findings are based on document reviews and interviews with a sample of cabinet Members and senior officers. The evidence we have used to inform our findings is limited to these sources. We undertook this work during April to July 2023.
- 3 We set out to answer the question '**In developing its digital strategy has the Council acted in accordance with the sustainable development principle and put in place proper arrangements to secure value for money in the use of its resources?**' We did this by exploring the following questions:
  - Is the Council's digital strategy informed by a good understanding of current and future trends?
  - Does the Council have a clear vision of what it wants to achieve through the use of digital technology?
  - Is the Council working effectively with the right people and partners to design and deliver its digital strategy?
  - Has the Council resourced delivery of its digital strategy so it can deliver long-term/preventative benefits?
  - Is the Council monitoring and reviewing progress?
  - Is the Council learning lessons from how it works?
- 4 **Appendix 1** sets out the detailed questions we set out to answer along with the audit criteria we used to arrive at our findings.

### Why we undertook this audit

- 5 This audit was undertaken to help fulfil the Auditor General's duties under section 17 of the Public Audit (Wales) Act 2004 (the 2004 Act) and section 15 of the Well-being of Future Generations (Wales) Act 2015.
- 6 We sought to:
  - provide assurance that councils' digital strategies will help to deliver well-being objectives in a way that secures value for money in the use of resources;
  - provide assurance that councils are acting in accordance with the sustainable development principle in the design of their digital strategies;

- explain how councils are using/planning to use digital technology to meet people's needs and deliver better outcomes; and
- inspire and empower councils and other public sector bodies by identifying and sharing examples of notable practice/approaches where relevant.

## The Council's digital strategy

- 7 The Council's Digital Strategy was adopted in 2018 and is due to be replaced by the end of 2023-24. It is a high-level document intended to provide guidance to support the Cardiff Council's ambition to digitalise services.
- 8 The Strategy focuses on delivering the Council's wellbeing objective 'modernising and integrating public services' which the Council considers central to the achievement of all other WBO's.
- 9 It is based on six principles:
  - the customer experience comes first;
  - digital interactions will become the first choice for our customers;
  - modern, fit-for purpose technology will be used to ensure efficiency;
  - technology solutions will be reused, purchased and developed responsibly;
  - digital services will support collaborative working to improve outcomes for our customers; and
  - digital services will be continually monitored, assessed and improved.
- 10 The digital vision for Cardiff is 'a connected city in which new technologies empower citizens to get the best from services that matter to them'.
- 11 The strategy is further supported by summaries which emphasise the importance of digital connectivity with stakeholders which is illustrated with specific examples and performance data from 2018-19. These include the connected citizen, management, workforce, partners, businesses and education and provides a bases for comparison of performance at the start of the strategy.

## What we found

### **The Council has a mature strategic approach to digital, but this lacks clear timebound objectives informed by service users to enable corporate oversight of its impact**

#### **The Council is planning over an appropriate timescale but has not clearly set out the anticipated short- or long-term impacts of its digital strategy**

- 12 The Council is planning over an appropriate timescale. It has considered what long-term means for its digital approach and has adopted a five-year timeframe to reflect digital technology is constantly changing at an ever-increasing pace. There are examples of longer-term thinking where the Council is investing to deliver benefits over the longer term. These include an increased presence of chatbot across the council's website and an increasing number of new services released on Cardiff Gov app. Planning for the longer term will reduce the risk of reliance on short-term interventions that may provide less value for money over the longer term.
- 13 The Council's digital strategy clearly articulates its strategic approach, seeking to deliver benefits by exploring new ways of working, increasing service accessibility, and improving customer service. However, the strategy does not set out the anticipated short- or long-term impacts of its approach with milestones against which to measure progress. It is therefore unclear how the Council will be able to effectively evaluate the impact and value for money of the strategy.

#### **The Council is drawing on data from a broad range of sources, but has not engaged with citizens, in developing its digital strategy**

- 14 The Council is drawing on a wide range of information from internal and external sources to develop its digital strategy. It uses external data to help understand current and future demographic trends in Cardiff to help target those residents in need of more support. It also scans the external environment and liaises with its partners to identify future technological advances which may be helpful in advancing its strategy.
- 15 It also uses internal data based on an understanding of current IT systems in place across the organisation and collects data to identify how citizens access council services across the many channels open to them.
- 16 The Council has not directly engaged with citizens in developing its digital strategy. It therefore follows that the Council has also not engaged with the full

diversity of those with an interest in the digital strategy, including groups who share protected characteristics.

- 17 Not involving the full diversity of those with an interest in the development and delivery of the digital strategy risks the design of approaches that do not meet the needs of citizens nor will deliver value for money. It is important for the Council to use this data to inform its strategic approach to digital, including how it could address the root causes of problems.

### **The Council's strategic approach to digital is integrated with its key strategies and wellbeing objectives and demonstrates how it is working with partners to address short- and long-term challenges**

- 18 The Council's digital strategy is integrated with its key strategic priorities. For example, its hybrid working policy and One Planet Cardiff strategy, by assisting staff to adopt agile working to help reduce the carbon impact of its staff commute. It is also aligned with the Council's Wellbeing objectives with digital being seen as key to supporting their delivery. Integrated plans and strategies can help reduce duplication and identify opportunities to deliver multiple benefits.
- 19 The Council is working with a wide range of partners through its approach to digital. For example, on agile workstations with emergency services, a joint housing allocation scheme with registered social landlords and several initiatives with higher education. Working collaboratively can assist in delivering better outcomes and value for money through sharing and pooling expertise, resources and information.

### **The Council has not set out the resource implications of delivering its digital strategy but is investing in projects that will accrue benefits over the medium and longer term**

- 20 The Council has not set out the anticipated resource implications of delivering it vulnerable children through better sharing of data across some Council departments and with police partners. Its digital strategy in the short, medium, and long term, including any intended savings. In the context of significant savings requirements, the Council manages its resources to deliver its digital strategy on a project-by-project basis which sets out costs and benefits over the life of the project. Not identifying the resource implications and intended financial benefits of its strategy increases the risk of the strategy not being delivered and reduces the ability of the Council to monitor the extent to which it is delivering value for money.
- 21 There are, however, examples where the Council is allocating resources to secure better outcomes over the long term. For example, through the 'single view of the child project'. This aims to improve arrangements for safeguarding

### **Whilst the Council monitors delivery of individual projects it does not monitor the delivery and overall impact of its digital strategy**

- 22 The digital strategy does not have clear short, medium and long-term objectives against which progress can be monitored.
- 23 The Council has set up a Digital Cardiff Board to monitor delivery of the strategy. The Board is chaired by the Chief Executive and is attended by the senior management team to drive forward the Digital First agenda. However, it monitors at a detailed corporate and directorate project level and meets on a basis dictated by need to unblock issues. It does not monitor the costs and benefits of delivering its digital strategy as a whole.
- 24 The Council's Cabinet and Senior Management Team who are accountable for delivering the digital agenda and the Cabinet Member for Finance, Modernisation and Performance who is responsible for overseeing the delivery of the digital programme do not have a framework available to them to enable corporate oversight of the delivery of the digital strategy.
- 25 Monitoring the delivery and impact of its digital strategy overall is an important part of arrangements to secure value money. This makes it difficult for the Council to monitor the overall impact and value for money of its strategic approach.

### **The Council is sharing lessons learnt with other councils and assesses the effectiveness of delivering digital projects internally but has not used this information to assess impacts from delivering its strategy**

- 26 The Council is sharing lessons learnt with other councils but has not regularly reviewed the effectiveness of its strategic approach to digital although we recognise that this arrangement was interrupted due to the pandemic.
- 27 During the lifecycle of the strategy between 2018 and 2023-24 it conducted an annual update in 2019-20 to review the work completed in the first year. It then reviewed lessons learned from its response to the pandemic during 2021-22 and applied this learning to a refresh of its digital strategy.
- 28 It has also looked to other councils and their approaches to delivering digital initiatives such as data warehousing and Robotic Process Automation. The Council also regularly reviews the effectiveness of delivering specific projects.
- 29 This information has not been used to assess any organisation wide impacts from delivering its digital strategy such as:
  - effectiveness of its collaborative activity, including sharing resources improving resilience and avoiding duplication;
  - effectiveness of its involvement activity, including the impact of the strategy on service users including those who are digitally excluded;
  - the impact of the strategy on those who share protected characteristics; and

- the economy, efficiency and effectiveness of the digital strategy overall in helping the Council to achieve its strategic objectives.
- 30 Regularly reviewing the effectiveness of its strategic approach to digital overall would strengthen the Council's ability to identify opportunities to improve the impact and value for money of its approach.

# Appendix 1

## Audit questions and audit criteria

Below are the questions we sought to answer in carrying out this audit, along with the audit criteria we used to arrive at our findings.

Main audit question: **In developing its digital strategy has the Council acted in accordance with the sustainable development principle and put in place proper arrangements to secure value for money in the use of its resources?**

### Exhibit 2: audit questions and audit criteria

Level 2 questions	Level 3 questions	Criteria
1. Is the Council's digital strategy informed by a good understanding of current and future trends?	1.1 Is there is a thorough understanding of the 'as is' (ie current demand/issues to be addressed) and the reasons why/underlying causes?	<ul style="list-style-type: none"> <li>• The Council has drawn on a broad range of information from internal and external sources to develop a thorough understanding of the 'as is' and how it is likely to change. This includes information (including data) relating to:                             <ul style="list-style-type: none"> <li>– service sustainability/resilience and resourcing challenges.</li> <li>– the needs of citizens and communities.</li> <li>– the underlying causes of current demand/issues to be addressed.</li> <li>– analysis of future trends and how they might impact, eg social, economic/political, environmental, cultural or technological. They might include known trends eg ageing population, depleting natural resources and particularly technological advances. They might also include those with a higher level of uncertainty eg jobs and skills needed in the future.</li> </ul> </li> <li>• The analysis of the 'as is' and how it is likely to change is well informed by involvement activity, as appropriate, that reflects recognised good practice (eg <a href="#">National Principles for Public Engagement in Wales</a>, Future Generations Commissioner for Wales advice and guidance).</li> </ul>
	1.2 Is there a thorough understanding of the long-term factors that will impact and the challenges and opportunities that may result (eg risks and opportunities)?	



Level 2 questions	Level 3 questions	Criteria
		<ul style="list-style-type: none"> <li>• The Council uses its evidence base effectively to:               <ul style="list-style-type: none"> <li>– identify actions in its strategic approach to digital that are likely to be most effective and why, including how they could address the root causes of problems;</li> <li>– inform decisions around its use of digital technology that seek to balance the need to meet short and longer-term objectives.</li> </ul> </li> </ul>
<p>2. Does the Council have a clear vision of what it wants to achieve through the use of digital technology?</p>	<p>2.1 Is the Council planning over an appropriate timescale?</p>	<ul style="list-style-type: none"> <li>• The Council has considered what long term means in planning its approach to digital – ie how far ahead it can/should plan and why (at least ten years with consideration of longer-term trends as appropriate).</li> <li>• The Council has considered how actions can deliver the best impact over that timeframe in terms of outcomes and most effective use of resources. This could include consideration of appropriate intervention points linked to the Commissioner’s definition of prevention. (More details can be found in: <a href="#">Taking account of the Well-being of Future Generations Act in the budget process – The Future Generations Commissioner for Wales</a>).</li> <li>• The Council has set out measures for its digital strategy that reflect short and long-term impacts and value for money, with milestones that reflect progress as appropriate.</li> <li>• The Council has set out how its digital strategy will be resourced over the longer term as far as is practical (see also criteria relating to integration).</li> </ul>
	<p>2.2 Has the Council thought about the wider impacts its digital strategy could have, including:</p>	<ul style="list-style-type: none"> <li>• The Council has considered how its digital strategy can make a contribution across the well-being goals.</li> <li>• Staff developing the digital strategy understand what colleagues and partners do and how their work relates, and have sought to integrate their</li> </ul>

Level 2 questions	Level 3 questions	Criteria
	<ul style="list-style-type: none"> <li>• how it could contribute to each of the seven national well-being goals?</li> <li>• how delivery will impact on the other things it is trying to achieve (ie its well-being objectives and wider priorities)?</li> <li>• how delivery will impact on other what other public bodies are trying to achieve (ie their well-being objectives)?</li> </ul>	<p>work with that of their colleagues from across the Council and with partner organisations.</p> <ul style="list-style-type: none"> <li>• Integration is evident in the alignment of the digital strategy with other key corporate strategies and service plans. For example medium-term financial plan, workforce plan, asset management strategies, well-being statement and carbon reduction plans.</li> <li>• The digital strategy is aligned with other strategic intents such as:               <ul style="list-style-type: none"> <li>– customer experience;</li> <li>– management of demand/reductions in demand failure and prevention; and</li> <li>– design and implementation of new service delivery models.</li> </ul> </li> <li>• The Council's digital strategy aligns with the plans/strategies of local and national partners including the Welsh Government's Digital Strategy for Wales Digital strategy and well-being plans.</li> </ul>
	<p>2.3 Is there a wide and common understanding of what the Council is trying to achieve?</p>	<ul style="list-style-type: none"> <li>• Councillors and senior officers responsible for implementing the digital strategy have a common and clear understanding of what the Council is trying to achieve and the intended impact on service delivery.</li> <li>• The Council's digital strategy is clearly communicated to staff and partners who may help deliver it.</li> </ul>

Level 2 questions	Level 3 questions	Criteria
<p>3. Is the Council working effectively with the right people and partners to design and deliver its digital strategy</p>	<p>3.1 Has the Council identified who it needs to involve?</p>	<ul style="list-style-type: none"> <li>• The Council has a good understanding of who will be directly and indirectly affected by its digital strategy and who it needs to involve.</li> <li>• The Council has effectively involved the full diversity of views in developing its digital strategy, including from non-traditional sources and from those it may have previously failed to reach.</li> </ul>
	<p>3.2 Is the Council effectively involving the full diversity of people affected by its digital strategy?</p>	<ul style="list-style-type: none"> <li>• The Council has provided genuine opportunities for people to influence the design and delivery of its digital strategy from an early stage, including representatives of groups who share protected characteristics.</li> <li>• The Council has used the results of involvement to shape the design and delivery of its digital strategy.</li> </ul>
	<p>3.3 Is the Council collaborating effectively with the right partners?</p>	<ul style="list-style-type: none"> <li>• The Council is collaborating to ensure it delivers better outcomes and value for money through its digital strategy and has put appropriate arrangements in place to support this, for example for: <ul style="list-style-type: none"> <li>– sharing or pooling expertise and resources;</li> <li>– sharing information;</li> <li>– ensuring effective monitoring, evaluation and accountability including consideration of value for money.</li> </ul> </li> </ul>

Level 2 questions	Level 3 questions	Criteria
4. Has the Council resourced delivery of its digital strategy so it can deliver long-term/preventative benefits?	4.1 Does the Council understand long-term resource implications?	<ul style="list-style-type: none"> <li>• The Council has assessed the costs and benefits of using digital technology to invest in long-term, preventative approaches and the cost (both financial and in terms of outcomes) of not doing so.</li> <li>• The Council has thought about the resources it will need to deliver its digital strategy over the medium and longer term (whole life costs) and how it could manage risks/meet those costs including, for example, planned 'invest to save' initiatives and managed reductions in technical debt.</li> <li>• The Council has calculated and set out any savings it intends to make through implementing its digital strategy.</li> </ul>
	4.2 Does the Council allocate resources to deliver better outcomes over the long-term?	<ul style="list-style-type: none"> <li>• Action (including preventative action) that is likely to contribute to better outcomes and/or use of resources over the longer term is promoted and supported, even: <ul style="list-style-type: none"> <li>– where this may limit the ability to meet some short-term needs;</li> <li>– where the benefits are likely to be accrued by or attributed to another organisation.</li> </ul> </li> </ul>

Level 2 questions	Level 3 questions	Criteria
5. Is the Council monitoring and reviewing progress?	5.1 Is the Council monitoring and reviewing progress towards, short, medium and longer-term objectives?	<ul style="list-style-type: none"> <li>• The Council monitors the costs and benefits of delivering its digital strategy from a value for money perspective.</li> <li>• The Council is measuring the wider contribution the digital strategy is making across its own/partnership objectives.</li> <li>• Progress is measured against short, medium and long-term objectives.</li> </ul>
6. Is the Council learning lessons from how it works?	6.1 Does the Council review the effectiveness of its digital strategy?	<ul style="list-style-type: none"> <li>• The Council regularly reviews the effectiveness of its digital strategy including:               <ul style="list-style-type: none"> <li>– effectiveness of its collaborative activity;</li> <li>– effectiveness of its involvement activity, including the impact of the strategy on service users including those who are digitally excluded;</li> <li>– the impact of the strategy on those who share protected characteristics;</li> <li>– the economy, efficiency and effectiveness of the digital strategy overall in helping the Council to achieve its strategic objectives.</li> </ul> </li> <li>• The Council has reviewed lessons learned from its response to the pandemic and is applying this learning to its digital strategy.</li> </ul>
	6.2 Does the Council share lessons learned from its approach to its digital strategy?	<ul style="list-style-type: none"> <li>• The Council shares and applies any lessons learned from the development and delivery of its digital strategy widely across the organisation, and with partners where relevant.</li> </ul>



Audit Wales

1 Capital Quarter

Cardiff CF10 4BZ

Tel: 029 2032 0500

Fax: 029 2032 0600

Textphone: 029 2032 0660

E-mail: [info@audit.wales](mailto:info@audit.wales)

Website: [www.audit.wales](http://www.audit.wales)

We welcome correspondence and telephone calls in Welsh and English.  
Rydym yn croesawu gohebiaeth a galwadau ffôn yn Gymraeg a Saesneg.

## Adolygiad Strategaeth Ddigidol – Cyngor Caerdydd

Blwyddyn archwilio: 2022-23

Dyddiad cyhoeddi: Rhagfyr 2023

Cyfeirnod y ddogfen: 3974A2023

Paratowyd y ddogfen hon fel rhan o waith a gyflawnir yn unol â swyddogaethau statudol.

Mewn achos o dderbyn cais am wybodaeth y gall y ddogfen hon fod yn berthnasol iddo, tynnir sylw at y Cod Ymarfer a gyhoeddwyd o dan adran 45 o Ddeddf Rhyddid Gwybodaeth 2000. Mae'r cod adran 45 yn nodi'r arfer wrth ymdrin â cheisiadau a ddisgwylir gan awdurdodau cyhoeddus, gan gynnwys ymgynghori â thrydydd partïon perthnasol. O ran y ddogfen hon, mae Archwilydd Cyffredinol Cymru a Swyddfa Archwilio Cymru yn drydydd partïon perthnasol. Dylid anfon unrhyw ymholiadau ynghylch datgelu neu aildefnyddio'r ddogfen hon at Archwilio Cymru yn [swyddog.gwybodaeth@archwilio.cymru](mailto:swyddog.gwybodaeth@archwilio.cymru).

We welcome correspondence and telephone calls in Welsh and English. Corresponding in Welsh will not lead to delay. Rydym yn croesawu gohebiaeth a galwadau ffôn yn Gymraeg a Saesneg. Ni fydd gohebu yn Gymraeg yn arwain at oedi.

Mae'r ddogfen hon hefyd ar gael yn Saesneg. This document is also available in English.



# Cynnwys

Adolygiad strategaeth ddigidol	
Crynodeb o'r adroddiad	4
Adroddiad manwl	
Yr hyn yr edrychom arno a pham – cwmpas yr archwiliad hwn	6
Yr hyn a ganfuom – mae gan y Cyngor ddull strategol aeddfed o ymdrin â digidol, ond nid oes gan hyn amcanion clir sy'n gysylltiedig ag amser wedi'u llywio gan ddefnyddwyr gwasanaeth i alluogi goruchwyllo corfforaethol o'i effaith.	8
Atodiadau	
Atodiad 1: cwestiynau allweddol a meini prawf archwilio	12

# Adolygiad strategaeth ddigidol

## Crynodeb o'r adroddiad

### Arddangosyn 1: crynodeb o'r adroddiad

Mae'r arddangosfa isod yn crynhoi'r rheswm pam y gwnaethom gynnal yr archwiliad hwn, ein canfyddiadau allweddol a'n hargymhellion ar gyfer y Cyngor.

#### Pam mae dull strategol o ymdrin â digidol yn bwysig?

- 1 Mae technoleg ddigidol yn allweddol i ddarparu ystod eang o wasanaethau'r cyngor mewn ffordd fwy economaidd, effeithlon ac effeithiol, mae hefyd yn ffordd bwysig i gynghorau gyflawni eu hamcanion lles a chyflawni datblygu cynaliadwy.
- 2 Gall cael dull strategol clir o ymdrin â digidol ddod â sawl budd megis:
  - sefydlu gweledigaeth gyffredin ar gyfer defnyddio digidol a'r canlyniadau arfaethedig ar gyfer cymunedau lleol sy'n gysylltiedig ag amcanion strategol y Cyngor.
  - Helpu i sicrhau bod defnydd cynghorau o dechnoleg ddigidol yn cyd-fynd â'u hamcanion strategol allweddol a chynlluniau a strategaethau eraill ac yn cael ei lywio gan ddealltwriaeth dda o dueddiadau'r presennol a'r dyfodol.
  - lleihau'r risg o ddblygu o fewn cynghorau a chyda phartneriaid.
  - ystyried adnoddau digidol cydlynol dros y tymor byr, canolig a hwy.
  - darparu fframwaith i fonitro cynnydd yn ei erbyn dros y tymor byr, hir a chanolig.

#### Ffocws ein harchwiliad

- 3 Gwnaethom edrych i ba raddau y datblygwyd dull strategol y Cyngor o ymdrin â digidol yn unol â'r egwyddor datblygu cynaliadwy ac a fydd yn helpu i sicrhau gwerth am arian wrth ddefnyddio adnoddau'r Cyngor.

#### Ein canfyddiadau allweddol

- 4 Mae gan y Cyngor ddull strategol aeddfed o ymdrin â digidol, ond nid oes gan hyn amcanion clir sy'n gysylltiedig ag amser. Mae'n cynllunio dros amserlen briodol yn seiliedig ar ddadansoddiad o dueddiadau'r presennol a'r dyfodol, ond nid yw wedi nodi'n glir effeithiau tymor byr neu hirdymor ei strategaeth ddigidol. Yn absenoldeb amcanion tymor byr canolig a

hirdymor ar gyfer ei strategaeth ddigidol, mae'n anodd i'r Cyngor fonitro a gwerthuso cynnydd yn erbyn ei strategaeth ddigidol dros y tymor canolig a'r tymor hwy.

- 5 Nid yw'r Cyngor wedi ymgysylltu'n uniongyrchol â'i ddinasyddion i ddatblygu ei strategaeth ddigidol. Mae peidio â chynnwys amrywiaeth lawn y rhai sydd â diddordeb mewn datblygu a chyflwyno'r strategaeth ddigidol yn peryglu dyluniad dulliau nad ydynt yn diwallu anghenion dinasyddion nac a fydd yn sicrhau gwerth am arian.
- 6 Mae cyflawni'r strategaeth yn cael ei fonitro ar sail prosiect wrth brosiect. O'r herwydd, nid yw'r goblygiadau o ran adnoddau, bodlonrwydd ac effeithiau defnyddwyr gwasanaeth wedi'u dadansoddi a'u coladu i ddarparu goruchwyliaeth gorfforaethol effeithiol o'r strategaeth a'i chyflawniadau. Mae hyn yn ei gwneud hi'n anodd i'r Cyngor fonitro cynnydd wrth gyflawni'r strategaeth yn ogystal â deall effaith gyffredinol a gwerth am arian dull strategol y Cyngor o ymdrin â digidol.

### **Ein hargymhellion ar gyfer y Cyngor**

#### **Cryfhau'r sylfaen dystiolaeth**

- A1 Er mwyn helpu i sicrhau bod ei strategaeth ddigidol nesaf yn wybodus a bod ei adnoddau'n cael eu targedu'n effeithiol, wrth ddatblygu ei strategaeth, dylai'r Cyngor dynnu ar dystiolaeth o ystod ehangach o ffynonellau, gan gynnwys mwy o gyfranogiad rhanddeiliaid sydd â diddordeb yn y strategaeth ddigidol.

#### **Nodi goblygiadau adnoddau**

- A2 Er mwyn helpu i sicrhau bod modd cyflawni ei strategaeth ddigidol nesaf ac i helpu i fonitro gwerth am arian, dylai'r Cyngor nodi goblygiadau adnoddau tymor byr a hirdymor ei gyflawni ynghyd ag unrhyw arbedion effeithlonrwydd a fwriadwyd.

#### **Trefniadau i wella goruchwyliaeth gorfforaethol.**

- A3 Er mwyn galluogi gwell goruchwyliaeth gorfforaethol ac asesu gwerth am arian o'i strategaeth ddigidol nesaf, dylai'r Cyngor gryfhau ei drefniadau ar gyfer monitro cynnydd o ran cyflawni'r strategaeth a'i heffaith gyffredinol dros y tymor byr, canolig a'r tymor hwy.

## Adroddiad manwl

### Yr hyn yr edrychom arno – cwmpas yr archwiliad hwn

- 1 Gwnaethom adolygu dull strategol y Cyngor o ymdrin â digidol, ac yn benodol i ba raddau y datblygwyd hyn yn unol â'r egwyddor datblygu cynaliadwy; ac y bydd yn helpu i sicrhau gwerth am arian wrth ddefnyddio adnoddau'r Cyngor.
- 2 Mae ein canfyddiadau yn seiliedig ar adolygiadau o ddogfennau a chyfweliadau gyda sampl o Aelodau'r Cabinet ac uwch swyddogion. Mae'r dystiolaeth a ddefnyddiwyd gennym i lywio ein canfyddiadau wedi'i chyfyngu i'r ffynonellau hyn. Gwnaethom y gwaith hwn yn ystod mis Ebrill i fis Gorffennaf 2023.
- 3 Aethom ati i ateb y cwestiwn **'Wrth ddatblygu ei strategaeth ddigidol a yw'r Cyngor wedi gweithredu yn unol â'r egwyddor datblygu cynaliadwy ac wedi rhoi trefniadau priodol ar waith i sicrhau gwerth am arian wrth ddefnyddio ei adnoddau?'**Rydym wedi gwneud hyn drwy archwilio'r cwestiynau canlynol:
  - A yw strategaeth ddigidol y Cyngor yn cael ei llywio gan ddealltwriaeth dda o dueddiadau'r presennol a'r dyfodol?
  - A oes gan y Cyngor weledigaeth glir o'r hyn y mae am ei gyflawni drwy ddefnyddio technoleg ddigidol?
  - A yw'r Cyngor yn gweithio'n effeithiol gyda'r bobl a'r partneriaid cywir i ddylunio a chyflawni ei strategaeth ddigidol?
  - A yw'r Cyngor wedi rhoi adnoddau i gyflawni ei strategaeth ddigidol fel y gall ddarparu manteision hirdymor/ataliol?
  - A yw'r Cyngor yn monitro ac yn adolygu cynnydd?
  - Ydy'r Cyngor yn dysgu gwersi o sut mae'n gweithio?
- 4 Mae **Atodiad 1** yn nodi'r cwestiynau manwl yr oeddem yn bwriadu eu hateb ynghyd â'r meini prawf archwilio a ddefnyddiwyd gennym i gyrraedd ein canfyddiadau.

### Pam yr ymgwymerwyd â'r archwiliad hwn

- 5 Cynhaliwyd yr archwiliad hwn i helpu i gyflawni dyletswyddau'r Archwilydd Cyffredinol o dan adran 17 o Ddeddf Archwilio Cyhoeddus (Cymru) 2004 (Deddf 2004) ac adran 15 o Ddeddf Llesiant Cenedlaethau'r Dyfodol (Cymru) 2015.

- 6 Rydym yn ceisio:
- rhoi sicrwydd y bydd strategaethau digidol cynghorau yn helpu i gyflawni amcanion llesiant mewn ffordd sy'n sicrhau gwerth am arian wrth ddefnyddio adnoddau;
  - rhoi sicrwydd bod cynghorau'n gweithredu yn unol â'r egwyddor datblygu cynaliadwy wrth ddylunio eu strategaethau digidol;
  - esbonio sut mae cynghorau'n defnyddio/cynllunio i ddefnyddio technoleg ddigidol i ddiwallu anghenion pobl a sicrhau gwell canlyniadau; ac
  - ysbrydoli a grymuso cynghorau a chyrff eraill yn y sector cyhoeddus drwy nodi a rhannu enghreifftiau o arfer/dulliau nodedig lle bo hynny'n berthnasol.

## Strategaeth ddigidol y Cyngor

- 7 Mabwysiadwyd Strategaeth Ddigidol y Cyngor yn 2018 ac mae disgwyl iddi gael ei disodli erbyn diwedd 2023-24. Mae'n ddogfen lefel uchel gyda'r bwriad o ddarparu arweiniad i gefnogi uchelgais Cyngor Caerdydd i ddigideiddio gwasanaethau.
- 8 Mae'r Strategaeth yn canolbwyntio ar gyflawni amcan llesiant y Cyngor sef 'moderneiddio ac integreiddio gwasanaethau cyhoeddus' y mae'r Cyngor yn ei ystyried yn ganolog i gyflawni pob un o'r Swyddogion Llesiant eraill.
- 9 Mae'n seiliedig ar chwe egwyddor:
- profiad y cwsmer sy'n dod gyntaf;
  - rhyngweithio digidol fydd y dewis cyntaf i'n cwsmeriaid;
  - bydd technoleg fodern, addas i'r diben yn cael ei defnyddio i sicrhau effeithlonrwydd;
  - bydd datrysiadau technoleg yn cael eu hailddefnyddio, eu prynu a'u datblygu'n gyfrifol;
  - bydd gwasanaethau digidol yn cefnogi cydweithio i wella canlyniadau i'n cwsmeriaid; a
  - bydd gwasanaethau digidol yn cael eu monitro, eu hasesu a'u gwella'n barhaus.
- 10 Y weledigaeth ddigidol ar gyfer Caerdydd yw 'dinas gysylltiedig lle mae technolegau newydd yn grymuso dinasyddion i gael y gorau o wasanaethau sy'n bwysig iddyn nhw'.
- 11 Cefnogir y strategaeth ymhellach gan grynodedbau sy'n pwysleisio pwysigrwydd cysylltedd digidol â rhanddeiliaid sy'n cael ei ddangos gydag enghreifftiau penodol a data perfformiad o 2018-19. Mae'r rhain yn cynnwys y dinesydd, rheolaeth, gweithlu, partneriaid, busnesau ac addysg cysylltiedig ac yn darparu seiliau ar gyfer cymharu perfformiad ar ddechrau'r strategaeth.

## Yr hyn a ganfuom

### **Mae gan y Cyngor ddull strategol aeddfed o ymdrin â digidol, ond nid oes gan hyn amcanion clir sy'n gysylltiedig ag amser wedi'u llywio gan ddefnyddwyr gwasanaeth i alluogi goruchwyllo corfforaethol o'i effaith**

#### **Mae'r Cyngor yn cynllunio dros amserlen briodol ond nid yw wedi nodi'n glir effeithiau tymor byr neu hirdymor ei strategaeth ddigidol**

- 12 Mae'r Cyngor yn cynllunio dros gyfnod amser priodol. Mae wedi ystyried beth mae ei ddull digidol yn ei olygu yn y tymor hir ac mae wedi mabwysiadu amserlen pum mlynedd i adlewyrchu technoleg ddigidol yn newid yn gyson ar gyflymder cynyddol. Mae yna enghreifftiau o feddwl tymor hwy lle mae'r Cyngor yn buddsoddi i ddarparu buddion dros y tymor hwy. Mae'r rhain yn cynnwys mwy o bresenoldeb chatbot ar draws gwefan y cyngor a nifer cynyddol o wasanaethau newydd sy'n cael eu rhyddhau ar ap Cardiff Gov. Bydd cynllunio ar gyfer y tymor hwy yn lleihau'r risg o ddibynnu ar ymyriadau tymor byr a allai ddarparu llai o werth am arian dros y tymor hwy.
- 13 Mae strategaeth ddigidol y Cyngor yn mynegi ei ddull strategol yn glir, gan geisio sicrhau manteision trwy archwilio ffyrdd newydd o weithio, cynyddu hygyrchedd gwasanaethau, a gwella gwasanaeth cwsmeriaid. Fodd bynnag, nid yw'r strategaeth yn nodi effeithiau tymor byr neu hirdymor disgwylledig ei dull o weithredu gyda cherrig milltir i fesur cynnydd yn eu herbyn. Felly, nid yw'n glir sut y bydd y Cyngor yn gallu gwerthuso effaith a gwerth am arian y strategaeth yn effeithiol.

#### **Mae'r Cyngor yn defnyddio data o ystod eang o ffynonellau, ond nid yw wedi ymgysylltu â dinasyddion, wrth ddatblygu ei strategaeth ddigidol**

- 14 Mae'r Cyngor yn defnyddio ystod eang o wybodaeth o ffynonellau mewnol ac allanol i ddatblygu ei strategaeth ddigidol. Mae'n defnyddio data allanol i helpu i ddeall tueddiadau demograffig cyfredol ac yn y dyfodol yng Nghaerdydd i helpu i dargedu'r preswylwyr hynny sydd angen mwy o gefnogaeth. Mae hefyd yn sganio'r amgylchedd allanol ac yn cysylltu â'i bartneriaid i nodi datblygiadau technolegol yn y dyfodol a allai fod o gymorth wrth ddatblygu ei strategaeth.
- 15 Mae hefyd yn defnyddio data mewnol yn seiliedig ar ddealltwriaeth o'r systemau TG cyfredol sydd ar waith ar draws y sefydliad ac yn casglu data i nodi sut mae dinasyddion yn cyrchu gwasanaethau'r cyngor ar draws y sianelau niferus sy'n agored iddynt.

- 16 Nid yw'r Cyngor wedi ymgysylltu'n uniongyrchol â dinasyddion i ddatblygu ei strategaeth ddigidol. Felly, mae'n dilyn nad yw'r Cyngor wedi ymgysylltu ag amrywiaeth lawn y rhai sydd â diddordeb yn y strategaeth ddigidol, gan gynnwys grwpiau sy'n rhannu nodweddion gwarchoddedig.
- 17 Mae peidio â chynnwys amrywiaeth lawn y rhai sydd â diddordeb mewn datblygu a chyflwyno'r strategaeth ddigidol yn peryglu dyluniad dulliau nad ydynt yn diwallu anghenion dinasyddion nac a fydd yn sicrhau gwerth am arian. Mae'n bwysig i'r Cyngor ddefnyddio'r data hwn i lywio ei ddull strategol o ymdrin â digidol, gan gynnwys sut y gallai fynd i'r afael ag achosion sylfaenol problemau.

### **Mae dull strategol y Cyngor o ymdrin â digidol wedi'i integreiddio â'i strategaethau allweddol a'i amcanion llesiant ac mae'n dangos sut mae'n gweithio gyda phartneriaid i fynd i'r afael â heriau tymor byr a thymor hir**

- 18 Mae strategaeth ddigidol y Cyngor wedi'i hintegreiddio â'i flaenoriaethau strategol allweddol. Er enghraifft, ei bolisi gweithio hybrid a'i strategaeth Caerdydd Un Blaned, trwy gynorthwyo staff i fabwysiadu gweithio ystwyth i helpu i leihau effaith carbon ei staff yn cymudo. Mae hefyd yn cyd-fynd ag amcanion Llesiant y Cyngor gyda bod digidol yn cael ei ystyried yn allweddol i gefnogi eu cyflawniad. Gall cynlluniau a strategaethau integredig helpu i leihau dyblygu a nodi cyfleoedd i gyflawni manteision lluosog.
- 19 Mae'r Cyngor yn gweithio gydag ystod eang o bartneriaid drwy ei ymagwedd at ddigidol. Er enghraifft, ar weithfannau ystwyth gyda'r gwasanaethau brys, cynllun dyrannu tai ar y cyd gyda landlordiaid cymdeithasol cofrestredig a sawl menter gydag addysg uwch. Gall cydweithio helpu i sicrhau gwell canlyniadau a gwerth am arian drwy rannu a chyfuno arbenigedd, adnoddau a gwybodaeth.

### **Nid yw'r Cyngor wedi nodi goblygiadau adnoddau cyflawni ei strategaeth ddigidol ond mae'n buddsoddi mewn prosiectau a fydd yn cronni buddion dros y tymor canolig a'r tymor hwy**

- 20 Nid yw'r Cyngor wedi nodi'r goblygiadau a ragwelir o ran adnoddau o ddarparu plant sy'n agored i niwed drwy rannu data yn well ar draws rhai adrannau'r Cyngor a chyda phartneriaid heddlu. strategaeth ddigidol yn y tymor byr, canolig a hir, gan gynnwys unrhyw arbedion bwriedig. Yng nghydestun gofynion arbedion sylweddol, mae'r Cyngor yn rheoli ei adnoddau i gyflawni ei strategaeth ddigidol ar sail prosiect wrth brosiect sy'n nodi costau a buddion dros oes y prosiect. Mae peidio â nodi goblygiadau adnoddau a buddion ariannol arfaethedig ei strategaeth yn cynyddu'r risg na fydd y strategaeth yn cael ei chyflawni ac yn lleihau gallu'r Cyngor i fonitro i ba raddau y mae'n darparu gwerth am arian.

- 21 Fodd bynnag, ceir enghreifftiau lle mae'r Cyngor yn dyrannu adnoddau i sicrhau canlyniadau gwell dros y tymor hir. Er enghraifft, drwy'r 'prosiect un farn o'r plentyn'. Nod hyn yw gwella'r trefniadau ar gyfer diogelu

### **Er bod y Cyngor yn monitro'r gwaith o gyflawni prosiectau unigol, nid yw'n monitro cyflawniad ac effaith gyffredinol ei strategaeth ddigidol**

- 22 Nid oes gan y strategaeth ddigidol amcanion tymor byr, canolig a hirdymor clir y gellir monitro cynnydd yn eu herbyn.
- 23 Mae'r Cyngor wedi sefydlu Bwrdd Caerdydd Digidol i fonitro'r broses o gyflawni'r strategaeth. Cadeirydd y Bwrdd yw'r Prif Weithredwr ac mae'r uwch dîm rheoli yn bresennol i yrru'r agenda Digital First ymlaen. Fodd bynnag, mae'n monitro ar lefel prosiect corfforaethol a chyfarwyddiaeth fanwl ac yn cwrdd ar sail a bennir gan yr angen i ddadffocio materion. Nid yw'n monitro costau a manteision cyflawni ei strategaeth ddigidol yn ei chyfanrwydd.
- 24 Nid oes gan Gabinet ac Uwch Dîm Rheoli y Cyngor sy'n atebol am gyflawni'r agenda ddigidol a'r Aelod Cabinet dros Gyllid, Moderneiddio a Pherfformiad sy'n gyfrifol am oruchwylio'r gwaith o gyflawni'r rhaglen ddigidol fframwaith sydd ar gael iddynt i alluogi goruchwylio corfforaethol ar gyflawni'r strategaeth ddigidol.
- 25 Mae monitro cyflawniad ac effaith ei strategaeth ddigidol yn gyffredinol yn rhan bwysig o drefniadau i sicrhau arian gwerth. Mae hyn yn ei gwneud hi'n anodd i'r Cyngor fonitro effaith gyffredinol a gwerth am arian ei ddull strategol.

### **Mae'r Cyngor yn rhannu gwersi a ddysgwyd gyda chynghorau eraill ac yn asesu effeithiolrwydd cyflwyno prosiectau digidol yn fewnol ond nid yw wedi defnyddio'r wybodaeth hon i asesu effeithiau o gyflawni ei strategaeth**

- 26 Mae'r Cyngor yn rhannu gwersi a ddysgwyd gyda chynghorau eraill ond nid yw wedi adolygu effeithiolrwydd ei ddull strategol o ymdrin â digidol yn rheolaidd, er ein bod yn cydnabod bod y trefniant hwn wedi cael ei dorri oherwydd y pandemig.
- 27 Yn ystod cylch bywyd y strategaeth rhwng 2018 a 2023-24 cynhaliodd ddiweddariad blynyddol yn 2019-20 i adolygu'r gwaith a gwblhawyd yn y flwyddyn gyntaf. Yna adolygodd y gwersi a ddysgwyd o'i hymateb i'r pandemig yn ystod 2021-22 a chymhwyso'r dysgu hwn i adnewyddu ei strategaeth ddigidol.
- 28 Mae hefyd wedi edrych ar gynghorau eraill a'u dulliau o gyflwyno mentrau digidol fel warysau data ac awtomeiddio prosesau robotig. Mae'r Cyngor hefyd yn adolygu effeithiolrwydd cyflwyno prosiectau penodol yn rheolaidd.
- 29 Nid yw'r wybodaeth hon wedi'i defnyddio i asesu unrhyw effeithiau ar draws sefydliadau o gyflawni ei strategaeth ddigidol fel:



- effeithiolrwydd ei weithgarwch cydweithredol, gan gynnwys rhannu adnoddau i wella gwytnwch ac osgoi dyblygu;
  - effeithiolrwydd ei weithgarwch cyfranogi, gan gynnwys effaith y strategaeth ar ddefnyddwyr gwasanaethau gan gynnwys y rhai sydd wedi'u hallgáu'n ddigidol;
  - effaith y strategaeth ar y rhai sy'n rhannu nodweddion gwarchoddedig; ac
  - economi, effeithlonrwydd ac effeithiolrwydd y strategaeth ddigidol yn gyffredinol wrth helpu'r Cyngor i gyflawni ei amcanion strategol.
- 30 Byddai adolygu effeithiolrwydd ei ddull strategol o ymdrin â digidol yn gyffredinol yn gyson yn cryfhau gallu'r Cyngor i nodi cyfleoedd i wella effaith a gwerth am arian ei ddull.

# Atodiad 1

## Cwestiynau archwilio a meini prawf archwilio

Isod mae'r cwestiynau y gwnaethom geisio eu hateb wrth gynnal yr archwiliad hwn, ynghyd â'r meini prawf archwilio a ddefnyddiwyd gennym i gyrraedd ein canfyddiadau.

Prif gwestiwn archwilio: **Wrth ddatblygu ei strategaeth ddigidol a yw'r Cyngor wedi gweithredu yn unol â'r egwyddor datblygu cynaliadwy ac wedi rhoi trefniadau priodol ar waith i sicrhau gwerth am arian wrth ddefnyddio ei adnoddau?**

### Arddangosyn 2: cwestiynau archwilio a meini prawf archwilio

Cwestiwn Lefel 2	Cwestiynau Lefel 3	Meini prawf
1. A yw strategaeth ddigidol y Cyngor yn cael ei llywio gan ddealltwriaeth dda o dueddiadau'r presennol a'r dyfodol?	1.1 A oes dealltwriaeth drylwyr o'r 'fel y mae' (h.y. y galw/materion cyfredol i'w datrys) a'r rhesymau pam/achosion sylfaenol?	<ul style="list-style-type: none"><li>• Mae'r Cyngor wedi defnyddio ystod eang o wybodaeth o ffynonellau mewnol ac allanol i ddatblygu dealltwriaeth drylwyr o'r 'fel y mae' a sut mae'n debygol o newid. Mae hyn yn cynnwys gwybodaeth (gan gynnwys data) sy'n ymwneud â:<ul style="list-style-type: none"><li>– Cynaliadwyedd gwasanaeth/gwytnwch a heriau adnoddau.</li><li>– Anghenion y cyhoedd a'r gymuned.</li><li>– achosion sylfaenol y galw/materion cyfredol i'w datrys.</li><li>– Dadansoddiad o dueddiadau'r dyfodol a sut y gallent effeithio, e.e. cymdeithasol, economaidd/gwleidyddol, amgylcheddol, diwylliannol neu dechnolegol. Gallent gynnwys tueddiadau hysbys ee poblogaeth sy'n heneiddio, lleihau adnoddau naturiol ac yn enwedig datblygiadau technolegol. Efallai y byddan nhw hefyd yn cynnwys y rhai sydd â lefel uwch o ansicrwydd, e.e. swyddi a sgiliau sydd eu hangen yn y dyfodol.</li></ul></li><li>• Mae'r dadansoddiad o'r 'fel y mae' a sut mae'n debygol o newid yn cael ei lywio'n dda gan weithgarwch cyfranogi, fel y bo'n briodol, sy'n adlewyrchu</li></ul>
	1.2 A oes dealltwriaeth drylwyr o'r ffactorau hirdymor a fydd yn effeithio a'r heriau a'r cyfleoedd a allai arwain (e.e. risgiau a chyfleoedd)?	

Cwestiwn Lefel 2	Cwestiynau Lefel 3	Meini prawf
		<p>arfer da cydnabyddedig (e.e. <a href="#">Egwyddorion Cenedlaethol ar gyfer Ymgysylltu â'r Cyhoedd yng Nghymru</a>, cyngor ac arweiniad Comisiynydd Cenedlaethau'r Dyfodol Cymru).</p> <ul style="list-style-type: none"> <li>• Mae'r Cyngor yn defnyddio ei sylfaen dystiolaeth yn effeithiol i: <ul style="list-style-type: none"> <li>– nodi camau yn ei ddull strategol o ymdrin â digidol sy'n debygol o fod fwyaf effeithiol a pham, gan gynnwys sut y gallent fynd i'r afael ag achosion sylfaenol problemau;</li> <li>– llywio penderfyniadau ynghylch ei ddefnydd o dechnoleg ddigidol sy'n ceisio cydbwysu'r angen i gyflawni amcanion tymor byr a thymor hwy.</li> </ul> </li> </ul>
<p>2. A oes gan y Cyngor weledigaeth glir o'r hyn y mae am ei gyflawni drwy ddefnyddio technoleg ddigidol?</p>	<p>2.1 A yw'r Cyngor yn cynllunio dros amserlen briodol?</p>	<ul style="list-style-type: none"> <li>• Mae'r Cyngor wedi ystyried beth mae tymor hir yn ei olygu wrth gynllunio ei ddull o ymdrin â digidol - hy pa mor bell ymlaen y gall / y dylai gynllunio a pham (o leiaf ddeng mlynedd gan ystyried tueddiadau tymor hwy fel y bo'n briodol).</li> <li>• Mae'r Cyngor wedi ystyried sut y gall camau gweithredu sicrhau'r effaith orau dros yr amserlen honno o ran canlyniadau a'r defnydd mwyaf effeithiol o adnoddau. Gallai hyn gynnwys ystyried pwyntiau ymyrraeth priodol sy'n gysylltiedig â diffiniad y Comisiynydd o atal. (Gellir dod o hyd i fwy o wybodaeth yn: <a href="#">Gan ystyried Deddf Llesiant Cenedlaethau'r Dyfodol yn y broses gyllidebol – The Future Generations Commissioner for Wales</a>).</li> <li>• Mae'r Cyngor wedi nodi mesurau ar gyfer ei strategaeth ddigidol sy'n adlewyrchu effeithiau tymor byr a hirdymor a gwerth am arian, gyda cherrig milltir sy'n adlewyrchu cynnydd fel y bo'n briodol.</li> <li>• Mae'r Cyngor wedi nodi sut y bydd ei strategaeth ddigidol yn cael adnoddau dros y tymor hwy cyn belled ag sy'n ymarferol (gweler meini prawf sy'n ymwneud ag integreiddio hefyd).</li> </ul>

Cwestiwn Lefel 2	Cwestiynau Lefel 3	Meini prawf
	<p>2.2 A yw'r Cyngor wedi meddwl am yr effeithiau ehangach y gallai ei strategaeth ddigidol eu cael, gan gynnwys:</p> <ul style="list-style-type: none"> <li>• Sut y gallai gyfrannu at bob un o'r saith nod llesiant cenedlaethol?</li> <li>• sut y bydd cyflawni yn effeithio ar y pethau eraill y mae'n ceisio eu cyflawni (h.y. ei amcanion llesiant a'i flaenoriaethau ehangach)?</li> <li>• sut y bydd cyflawni yn effeithio ar eraill yr hyn y mae cyrff cyhoeddus eraill yn ceisio ei gyflawni (h.y. eu hamcanion llesiant)?</li> </ul>	<ul style="list-style-type: none"> <li>• Mae'r Cyngor wedi ystyried sut y gall ei strategaeth ddigidol wneud cyfraniad ar draws y nodau llesiant.</li> <li>• Mae staff sy'n datblygu'r strategaeth ddigidol yn deall beth mae cydweithwyr a phartneriaid yn ei wneud a sut mae eu gwaith yn ymwneud â nhw, ac wedi ceisio integreiddio eu gwaith gyda gwaith eu cydweithwyr o bob rhan o'r Cyngor a chyda sefydliadau partner.</li> <li>• Mae integreiddio yn amlwg wrth alinio'r strategaeth ddigidol â strategaethau corfforaethol allweddol eraill a chynlluniau gwasanaeth. Er enghraifft, cynllun ariannol tymor canolig, cynllun gweithlu, strategaethau rheoli asedau, datganiad llesiant a chynlluniau lleihau carbon.</li> <li>• Mae'r strategaeth ddigidol yn cyd-fynd â dibenion strategol eraill fel: <ul style="list-style-type: none"> <li>– profiad y cwsmer;</li> <li>– rheoli galw/gostyngiadau mewn methiant ac atal galw; a</li> <li>– dylunio a gweithredu modelau cyflenwi gwasanaeth newydd.</li> </ul> </li> <li>• Mae strategaeth ddigidol y Cyngor yn cyd-fynd â chynlluniau/strategaethau partneriaid lleol a chenedlaethol gan gynnwys strategaeth ddigidol a chynlluniau llesiant Strategaeth Ddigidol i Gymru Llywodraeth Cymru.</li> </ul>
	<p>2.3 A oes dealltwriaeth eang a chyffredin o'r hyn y mae'r Cyngor yn ceisio'i gyflawni?</p>	<ul style="list-style-type: none"> <li>• Mae gan gynghorwyr ac uwch swyddogion sy'n gyfrifol am weithredu'r strategaeth ddigidol ddealltwriaeth gyffredin a chdir o'r hyn y mae'r Cyngor yn ceisio ei gyflawni a'r effaith a fwriedir ar ddarparu gwasanaethau.</li> <li>• Mae strategaeth ddigidol y Cyngor yn cael ei chyfleu'n glir i staff a phartneriaid a allai helpu i'w chyflawni.</li> </ul>

Cwestiwn Lefel 2	Cwestiynau Lefel 3	Meini prawf
<p>3. A yw'r Cyngor yn gweithio'n effeithiol gyda'r bobl a'r partneriaid cywir i ddylunio a chyflawni ei strategaeth ddigidol</p>	<p>3.1 A yw'r Cyngor wedi nodi pwy sydd angen ei gynnwys?</p>	<ul style="list-style-type: none"> <li>• Mae gan y Cyngor ddealltwriaeth dda o bwy fydd yn cael ei effeithio'n uniongyrchol ac yn anuniongyrchol gan ei strategaeth ddigidol a phwy y mae angen iddo ei gynnwys.</li> <li>• Mae'r Cyngor i bob pwrpas wedi cynnwys yr amrywiaeth lawn o safbwyntiau wrth ddatblygu ei strategaeth ddigidol, gan gynnwys o ffynonellau anhraddodiadol ac o'r rhai y gallai fod wedi methu â chyrraedd o'r blaen.</li> </ul>
	<p>3.2 A yw'r Cyngor i bob pwrpas yn cynnwys yr amrywiaeth lawn o bobl y mae ei strategaeth ddigidol yn effeithio arnynt?</p>	<ul style="list-style-type: none"> <li>• Mae'r Cyngor wedi darparu cyfleoedd gwirioneddol i bobl ddylanwadu ar ddylunio a chyflawni ei strategaeth ddigidol o gam cynnar, gan gynnwys cynrychiolwyr grwpiau sy'n rhannu nodweddion gwarchoddedig.</li> <li>• Mae'r Cyngor wedi defnyddio canlyniadau cyfranogiad i lunio dyluniad a chyflwyniad ei strategaeth ddigidol.</li> </ul>
	<p>3.3 A yw'r Cyngor yn cydweithio'n effeithiol â'r partneriaid cywir?</p>	<ul style="list-style-type: none"> <li>• Mae'r Cyngor yn cydweithio i sicrhau ei fod yn cyflawni gwell canlyniadau a gwerth am arian drwy ei strategaeth ddigidol ac wedi rhoi trefniadau priodol ar waith i gefnogi hyn, er enghraifft: <ul style="list-style-type: none"> <li>– rhannu neu rannu arbenigedd ac adnoddau;</li> <li>– rhannu gwybodaeth;</li> <li>– sicrhau monitro, gwerthuso ac atebolrwydd effeithiol gan gynnwys ystyried gwerth am arian.</li> </ul> </li> </ul>

Cwestiwn Lefel 2	Cwestiynau Lefel 3	Meini prawf
<p>4. A yw'r Cyngor wedi rhoi adnoddau i gyflawni ei strategaeth ddigidol fel y gall ddarparu manteision hirdymor/ataliol?</p>	<p>4.1 A yw'r Cyngor yn deall goblygiadau adnoddau tymor hir?</p>	<ul style="list-style-type: none"> <li>• Mae'r Cyngor wedi asesu costau a manteision defnyddio technoleg ddigidol i fuddsoddi mewn dulliau ataliol tymor hir a'r gost (yn ariannol ac o ran canlyniadau) peidio â gwneud hynny.</li> <li>• Mae'r Cyngor wedi meddwl am yr adnoddau y bydd eu hangen arno i gyflawni ei strategaeth ddigidol dros y tymor canolig a'r tymor hwy (costau oes cyfan) a sut y gallai reoli risgiau/cwrdd â'r costau hynny, gan gynnwys, er enghraifft, cynlluniau 'buddsoddi i arbed' a gostyngiadau rheoledig mewn dyled dechnegol.</li> <li>• Mae'r Cyngor wedi cyfrifo a nodi unrhyw arbedion y mae'n bwriadu eu gwneud drwy weithredu ei strategaeth ddigidol.</li> </ul>
	<p>4.2 A yw'r Cyngor yn dyrannu adnoddau i sicrhau gwell canlyniadau dros y tymor hir?</p>	<ul style="list-style-type: none"> <li>• Mae camau gweithredu (gan gynnwys camau ataliol) sy'n debygol o gyfrannu at well canlyniadau a/neu ddefnydd o adnoddau dros y tymor hwy yn cael eu hyrwyddo a'u cefnogi, hyd yn oed: <ul style="list-style-type: none"> <li>– lle gallai hyn gyfyngu ar y gallu i ddiwallu rhai anghenion tymor byr;</li> <li>– lle mae'r buddion yn debygol o gael eu cronni gan, neu eu priodoli i sefydliad arall.</li> </ul> </li> </ul>

Cwestiwn Lefel 2	Cwestiynau Lefel 3	Meini prawf
5. A yw'r Cyngor yn monitro ac yn adolygu cynnydd?	5.1 A yw'r Cyngor yn monitro ac yn adolygu cynnydd tuag at amcanion tymor byr, canolig a thymor hwy?	<ul style="list-style-type: none"> <li>• Mae'r Cyngor yn monitro costau a manteision cyflawni ei strategaeth ddigidol o safbwynt gwerth am arian.</li> <li>• Mae'r Cyngor yn mesur y cyfraniad ehangach y mae'r strategaeth ddigidol yn ei wneud ar draws ei amcanion ei hun/partneriaeth.</li> <li>• Caiff cynnydd ei fesur yn erbyn amcanion tymor byr, canolig a thymor hir.</li> </ul>
6. Ydy'r Cyngor yn dysgu gwersi o sut mae'n gweithio?	6.1 A yw'r Cyngor yn adolygu effeithiolrwydd ei strategaeth ddigidol?	<ul style="list-style-type: none"> <li>• Mae'r Cyngor yn adolygu effeithiolrwydd ei strategaeth ddigidol yn rheolaidd, gan gynnwys: <ul style="list-style-type: none"> <li>– effeithiolrwydd ei weithgarwch cydweithredol;</li> <li>– effeithiolrwydd ei weithgarwch cyfranogi, gan gynnwys effaith y strategaeth ar ddefnyddwyr gwasanaethau gan gynnwys y rhai sydd wedi'u hallgáu'n ddigidol;</li> <li>– effaith y strategaeth ar y rhai sy'n rhannu nodweddion gwarchoddedig;</li> <li>– economi, effeithlonrwydd ac effeithiolrwydd y strategaeth ddigidol yn gyffredinol wrth helpu'r Cyngor i gyflawni ei amcanion strategol.</li> </ul> </li> <li>• Mae'r Cyngor wedi adolygu gwersi a ddysgwyd o'i ymateb i'r pandemig ac mae'n cymhwyso'r dysgu hwn i'w strategaeth ddigidol.</li> </ul>
	6.2 A yw'r Cyngor yn rhannu gwersi a ddysgwyd o'i ymagwedd at ei strategaeth ddigidol?	<ul style="list-style-type: none"> <li>• Mae'r Cyngor yn rhannu ac yn cymhwyso unrhyw wersi a ddysgwyd o ddatblygu a chyflwyno ei strategaeth ddigidol yn eang ar draws y sefydliad, a gyda phartneriaid lle bo hynny'n berthnasol.</li> </ul>



Archwilio Cymru  
1 Cwr y Ddinas  
Caerdydd CF10 4BZ

Ffôn: 029 2032 0500

Ffacs: 029 2032 0600

Ffôn testun: 029 2032 0660

E-bost: [post@archwilio.cymru](mailto:post@archwilio.cymru)

Gwefan [www.archwilio.cymru](http://www.archwilio.cymru)

We welcome correspondence and telephone calls in Welsh and English.  
Rydym yn croesawu gohebiaeth a galwadau ffôn yn Gymraeg a Saesneg.



## Organisational response

**Report title:** Digital Strategy Review- City of Cardiff Council

**Completion date:** November 2023]

**Document reference:** FINAL

Ref	Recommendation	Organisational response Please set out here relevant commentary on the planned actions in response to the recommendations	Completion date Please set out by when the planned actions will be complete	Responsible officer (title)
R1	<p><b>Strengthening the evidence base</b></p> <p>To help ensure that its next digital strategy is well informed and that its resources are effectively targeted, in developing its strategy the Council should draw on evidence from a wider range of sources, including greater involvement of stakeholders with an interest in the digital strategy.</p>	<p>In the development of the next digital strategy Cardiff will be completing the following activities</p> <ul style="list-style-type: none"> <li>• Engaging through consultation with internal stakeholders to identify digital activities planned or taking place to identify the following: <ul style="list-style-type: none"> <li>○ Drivers for change – Efficiency, Process improvements or better outcomes for citizens.</li> <li>○ Current and planned resource levels with associated funding</li> <li>○ What additional support would be required – training, project management, data collection and analysis etc</li> </ul> </li> <li>• The organisation will continue its work in engaging with Citizens to help shape the strategy's priorities: <ul style="list-style-type: none"> <li>○ Analyse the feedback from the latest "Digital" survey to understand the current habits and expectations from Citizens</li> <li>○ Use the Digital Exclusion Risk Index to help identify where citizen may need the greatest assistance to access the digital offer</li> <li>○ Consult with the City on the proposals in the new strategy to ensure that it will meets the needs of the city and deliver value.</li> </ul> </li> </ul>	24/25	Isabelle Bignall <b>Chief Digital Officer</b>

		<p><b>Identifying resource implications</b></p> <p>To help ensure that its next digital strategy is deliverable and to help monitor value for money the Council should identify the short and long-term resource implications of delivering it together with any intended efficiency savings.</p>		
R2	<p><b>Identifying resource implications</b></p> <p>To help ensure that its next digital strategy is deliverable and to help monitor value for money the Council should identify the short and long-term resource implications of delivering it together with any intended efficiency savings.</p>	<p>Once the internal consultation is completed Cardiff will be better placed to identify the basis for its digital activities. We will identify what resources are currently in place, the cost of these roles and skills associated. We will look to formalise the training plans for staff to ensure they are sufficiently competent in delivering digital projects both through extending agile training but also leaning on DDaT roles and skills base to ensure suitably skilled staff are employed.</p> <p>Plans will be monitored financially over the short and long term to ensure efficiency savings as a result of the work are measured and checked against the business cases upon which they are based.</p> <p>A digital leads network will be created to ensure that any opportunities to share resources and skills are maximised.</p>	24/25	<p>Isabelle Bignall</p> <p><b>Chief Digital Officer</b></p>
R3	<p><b>Arrangements to improve corporate oversight.</b></p>	<p>Once information gathering through directorates is complete the activities will be mapped and</p>	24/25	<p>Isabelle Bignall</p>

To enable better corporate oversight and assessment of value for money from its next digital strategy, the Council should strengthen its arrangements for monitoring both progress in delivering the strategy and its overall impact over the short, medium and longer term.

tracked. Updates on progress will be reviewed through the existing Digital Board structure using the existing Portfolio, Programme and Project management database within the organisation.

Projects will be reviewed for their measures of success both against achievability and to ensure that they are delivering within the expected timeframes.

**Chief Digital Officer**

**GOVERNANCE & AUDIT COMMITTEE: 23 JANUARY 2024**

---

**COUNCIL COMPLAINTS – MID-YEAR REPORT****AGENDA ITEM: 8.1****REPORT OF THE CHIEF DIGITAL OFFICER**

---

**Reason for this Report**

1. This report has been produced to enable the Governance and Audit Committee to review and assess the authority's ability to handle complaints effectively and make any associated reports and recommendations.
2. The Governance and Audit Committee has incorporated the above responsibility into its terms of reference, as required in accordance with the provisions of the Local Government and Elections (Wales) Act 2021.

**Background - Halo**

3. Members will be aware from previous committee meetings that the Authority has committed to the introduction of a single, corporately owned system for Complaints, Cabinet Member Enquiries & Member Enquiries (Halo). The aim of the council-wide system is to improve the handling process, increase efficiency and provide corporate oversight of the complaints and member / cabinet enquiries across the organisation.
4. Members of the Committee have been actively involved in our transformative journey since our initial presentation in July 2022. As of the publication of this report, Members are well-informed about our imminent launch scheduled for the end of January 2024. Your engagement and support has been pivotal in shaping the successful development and impending deployment of our initiatives.
5. The journey undertaken has not only involved the establishment of a robust and efficient mechanism for handling complaints and enquiries but has also seen a significant increase in member and staff engagement regarding the system. This comprehensive initiative reflects our commitment to transparency, accountability and continuous improvement.
6. The journey began with meticulous planning, involving extensive stakeholder consultation and a thorough assessment of existing systems. All of the above has been detailed during previous presentations in 2022 and 2023. Each phase of the implementation process was carefully executed to ensure minimal disruption and the creation of a dedicated Project Manager and Project Board has meant minimal disruption to the Council's day-to-day complaints work.

7. As a summary for Committee, Phase 1 (configuration and testing phase) involved intensive testing of the system with any identified bugs and issues raised with Halo for fixes. During this time, a Project Manager was appointed in addition to a dedicated ICT Halo Support Engineer. Comprehensive meetings were undertaken with shareholders to discuss dashboards and reporting requirements. In addition to ongoing fixes for bugs and issues discovered through testing, further configuration and development work has taken place including HTML templates, emails, notifications, and attachment views. A Cabinet and Members 'test' instance was created and trialled (soft launch) in April 2023 ahead of full launch in August 2023. All testing of instances were completed over a series of days at County Hall, with ICT present to resolve issues and make configuration changes as needed. The Training resource for the Cabinet / Members instance was finalised and added to the SharePoint landing area. Finally, communications were created to make staff aware of the introduction of a new system.
8. Following this, the launch of Cabinet and Member Enquiries (Phase 2 of the project) took place in August 2023 and has been very well received with no significant issues reported. A review workshop took place in December 2023 and, following system and process changes discussed during the workshop, this enabled the Project Board to continue with Phase 3 and the long-awaited Complaints instance of the Halo project. Work was a continuation from the significant work that which had already taken place with creation of Cabinet and Member Enquiries instance.
9. ICT subsequently created the Complaints test instance and the Project Team have had several run-throughs of the system with end-to-end tickets. All has been reported to work well and workshops have taken place with Complaints Officers and Projects Team to run through the process in anticipation of the imminent launch. As mentioned, the Corporate Complaints ticket type is based on the Enquiries workflow, meaning many officers will already have awareness of the system.
10. The main point of discussion for the complaints instance has been the creation of an Application Programming Interface (API) - a way for two systems to connect with each other. This has needed to be created to enable the connection of the C2C escalations system (through which main complaints are received) with Halo. This has been successfully created and test tickets have been successfully sent from C2C to Halo.
11. Numerous training sessions have been implemented, both face-to-face and online. We have also developed a comprehensive user guide and accompanying video which will assist with some of the common issues and questions our colleagues may have.
12. We have recognised the growing demand on support officers and there has been a strategic shift in our approach as a result. Going forward, we will encourage service areas and users to utilize the SharePoint area directly rather than reaching out directly to the project team and Corporate Complaints. This transition aims to streamline operations and alleviate the strain on support officers, ensuring a more efficient and sustainable workflow.
13. In recognition of this, the project team has successfully produced 11 concise 'how-to' videos in advance of the introduction of Phase 3. These videos have been distributed to Service Areas and added to the SharePoint site.
14. Further meetings have taken place with Halo to discuss building bespoke reports and dashboards. This is in addition to the comprehensive report function where pre-built reports already exist.

15. A dedicated SharePoint page has been created and which has links to training options. Over the last eighteen months, we have developed comprehensive training packages (some in conjunction with the Ombudsman) and these are available for our staff that will handle complaints. These training resources will encourage quality and consistency in our complaint responses.
16. Regular project updates have taken place with Operational Managers and Senior Managers (who will be approving responses within the new system). This is to remind them of their responsibilities and to encourage the “buy-in” necessary for this project to succeed.
17. During our previous visits, we have presented to members that it is our contention that we do currently deal with complaints effectively. However, it remains our position that the implementation of the council-wide system will drive efficiencies and improvements via a standardisation of approach and greater monitoring capabilities, particularly when it comes to recording and reporting on complaints.
18. The successful implementation of the council-wide complaints system represents a milestone in our commitment to “handle complaints effectively”. The journey undertaken over the past two years has not only modernised our approach to complaint management but has also strengthened our relationship with stakeholders. As we move forward, continuous monitoring and adaptation will be key to ensuring the sustained success of the system and meeting the evolving needs of our citizens.

## Internal Audit

19. In June 2023, as part of the Council’s Internal Audit Plan, a review was completed on the Council’s Complaints and Compliments arrangements across the Council. The objectives of the audit mirrored the areas that the Governance & Audit Committee require assurance on, and included; to review and assess the authority’s ability to oversee compliments and complaints effectively and efficiently, ensure policies and procedures are in place and accurate records are maintained and that the procedures are supported by guidance and training for all staff involved in the compliments and complaints process.
20. Following the audit, the auditor was able to provide an assurance level of **Effective with opportunity for improvement** and there were five recommendations that were raised in the audit, the first four relating to our Corporate Complaints team with the fifth related to Education- Governor Services. These recommendations included:
  - Re-establishment of Corporate Complaints office meetings on a quarterly basis, to be chaired by the corporate team and where officers can learn from the complaints ‘group’ and receive peer support.
  - Update of Standard Operating Procedure (SOP) particularly around definition of a complaint – and to discuss with complaints group – to support consistent application of the policy across the Council.
  - For all efforts to be made to get the HALO system implemented within set timescales.
  - Following the roll-out of HALO, a quality assurance system to be developed centrally on compliance and the efficiency and effectiveness of complaints handling.
  - For a briefing note to be provided to schools and their Governing Bodies at the end of each financial year, together with a termly checklist to remind them of key responsibilities.

21. We can confirm that recommendations 1 and 2 are complete and we are making steady progress with recommendations 3 and 4. Recommendation 5 has been accepted by Governor Services for delivery in March 2024. A copy of the Action Plan is found at Appendix C.

## **Complaints Handling**

22. The Authority has separate teams to deal with our Adult Services, Children's Services and Corporate Complaints respectively, whilst each school Governing Body will have its own arrangements for complaints handling in their respective school. During the last twelve to eighteen months, the Committee has received assurance and high-level details of complaints handling arrangements in each of the above arrangements.

23. The Committee's terms of reference include the responsibility to "review and assess the authority's ability to handle complaints effectively", for which further details are provided in the following paragraphs.

24. In terms of current assurances, the Authority can take assurance from the consideration of the Ombudsman that the Council's complaints handling policy is deemed to be compliant with the Ombudsman principles and model complaints handling policy.

25. The Corporate Complaints Team continue to provide advice and support to complaints contacts across the council on a weekly basis. As recommended by the Internal Audit, the team also facilitates a quarterly meeting of the complaints contacts to discuss any key issues, share good practice and to capture any lessons that can be learned to inform service improvement.

26. Complaints Officers in each Directorate have access to appropriate training and the Authority has developed a bespoke training package (in conjunction with the Ombudsman) which is available to all council officers. The Corporate Complaints Team make the recommendation that complaints-specific training will be compulsory for all officers who handle complaints and these officers will receive training by the end of the calendar year.

27. During 2022/23, a Standard Operating Procedures has been introduced to assist complaints officers in terms of how to handle complaints. This document has been developed to ensure an increased consistency of approach across the Authority and should result in greater efficiency.

28. The Complaints Team have undertaken broader initiatives related to complaints, including the enhancement of our website interface. This involved a revision of our online complaints form as citizens had been complaining about matters that we would not ordinarily consider under our Corporate Complaints process. To clarify, these citizens are now signposted to more appropriate channels in which to share their concerns, such as those matters that have their own separate appeal mechanism e.g. Council Tax appeals, Homelessness appeals, Planning applications and Penalty Charge Notices.

29. This change took place in November, and it has been reported that complaints received by the above channel are down by over 50% since this change. Ultimately, this change has improved consistency as we now have a truer value of what is a complaint and what is not.

## **Mid-Year Complaints Report**

30. Our Mid-Year Complaints Report 2023-24 can be found at Appendix 1. Members of the Committee will note that 1,856 complaints were recorded by Cardiff Council during the first



six months of the financial year. Though this figure only represents six months, it does suggest that we will receive more complaints than in 2022-23, when 3,071 complaints were recorded.

31. Though the number of complaints is set to increase, early indications are that our response rate will improve in 2023-24. For the first six months of 2023-24, 73.4% of our complaints received a full response within our corporate timescales (20 working days). This represents an increase from 2022-23 when 56% received a response within 20 working days.
32. It is envisaged that, once the council-wide system is in place, future Complaints and Compliments Reports will place more importance on what we as an Authority are learning from complaints, to support improvement in complaint handling and in service delivery. This information will be regularly collated and analysed so that decision makers can regularly review the information gathered from complaints when planning service delivery.
33. Members are reminded that there are separate processes for dealing with complaints about Social Services and that Social Services have their own procedure and teams for managing complaints.

### **Legal Implications**

34. Under Part 6 of the Local Government and Elections (Wales) Act 2021, section 115, Governance and Audit Committees are given new statutory functions, with effect from 1st April 2021, to 'review and assess the authority's ability to handle complaints effectively', and 'make reports and recommendations in relation to the authority's ability to handle complaints effectively'. The information set out in the report and appendices is provided for the Committee to review, assess and consider whether to make any reports and recommendations to the authority in this regard. In discharging its functions, the Committee must have regard to any relevant guidance issued by the Welsh Government.

### **Financial Implications**

35. The financial implications (if any) arising from this report have been contained within the body of the report.

### **RECOMMENDATIONS**

36. That the Governance and Audit Committee considers and notes the content of the report, in respect of its role to review and assess the authority's ability to handle complaints effectively, and to make any associated reports and recommendations.

**Isabelle Bignall**  
**Chief Digital Officer**

The following are attached:

- Appendix A:** Mid-Year Complaints Report 2023-24
- Appendix B:** Presentation Slides
- Appendix C:** Internal Audit Action Plan

This page is intentionally left blank



**STRONGER  
FAIRER  
GREENER**



8.1 Appendix A

# Cardiff Council

## Mid-Year Complaints Report 2023/24





STRONGER  
FAIRER  
GREENER



## 1. Reason for this report

To report to the Cabinet on the operation of the corporate complaints procedure between 1st April 2023 and 30<sup>th</sup> September 2023. The statistics for corporate complaints are set out by service area.

In order to allow comparisons, the report also contains complaint data covering the previous financial year – 2022/23.

By way of background, in 2019 the Ombudsman gained new powers under the Public Services Ombudsman for Wales Act 2019, this received Royal Assent in May 2019. Part of the act detailed a commitment for Local Authorities to report on complaints to senior management twice a year. The Local Authority will continue to provide an Annual Complaints Report every year to Cabinet. This second report is provided to Informal Cabinet and allows the Local Authority to ‘take stock’ at the six-month period.

A complaint is defined within the Council as:

*“An expression of dissatisfaction, however made, about the standard of service, action or lack of action by the Council, or its staff, affecting an individual customer or group of customers.”*

Complaints recorded under the corporate complaints procedure do not include ‘first time’ representations which are effectively requests for a service and dealt with as such. A new report of a pothole or a missed bin for example, would not be registered as a complaint, but as a request for service. Of course, in the event that we failed to respond to the ‘request’ appropriately, then that may generate a complaint.



## 2. Our complaints procedure

The Council's complaints procedure reflects guidance given in the Welsh Government Model Policy and Guidance Paper for Handling Complaints. This was further supported by the Public Services Ombudsman for Wales.

Complaints, comments and compliments can be made face-to-face or by telephone, email, letter or by using the online form found on the Council's website.



**Complaint received.** A complaint can be registered via any Council venue and once received, should be forwarded to the Service Area Complaints Manager. Every Council service area has a lead officer for complaints. The Complaints Manager will ensure complaints are acknowledged and recorded and facilitate the investigation of the complaint in accordance with the corporate complaints procedure.

**Acknowledgment.** The Complaints Managers will aim to acknowledge complaints within 5 working days. At this stage, we can let the customer know who is dealing with their complaint and our understanding of what the customer's complaint entails. We can also let the customer know that a full response will follow within 20 working days of our receipt of the complaint.

**Full response.** At the end of an investigation, a response should be produced depending on how a customer has indicated they prefer to be contacted. The response should include the outcome of the investigation as well as any necessary action taken for service improvement. The Public Services Ombudsman for Wales states that the aim of every formal investigation should be to "investigate once, investigate well". Advice will also be included on the full response on what the complainant should do if they remain dissatisfied with the outcome – to contact the Ombudsman.

**Public Services Ombudsman for Wales.** Complaints that progress to the Ombudsman will have been thoroughly investigated by the service area. If a complainant remains dissatisfied, it is for the Ombudsman to assess whether there is any evidence of service failure or maladministration not identified by the Council.



### 3. Complaints for Cardiff Council in 2023-24

A total of **1,856** complaints were recorded during the first six months of 2023-24.

Year	Number of complaints
<b>2023-24 (Q1 &amp; Q2 only)</b>	<b>1,856</b>
2022-23	3,071
2021-22	3,633
2020-21	2,537
2019-20	2,859

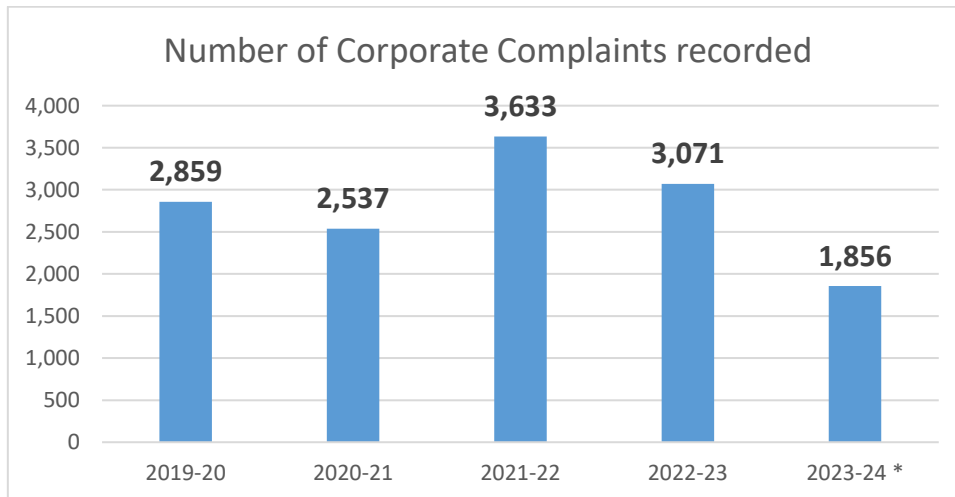

\*Q1 & Q2 only

## 4. Complaints breakdown for Cardiff Council

A total of **1,856** complaints were recorded during the first six months of 2023-24.

A breakdown of the number of complaints received by service area can be found below.

Service Area	Number of complaints 2022-23	Number of complaints Q1 & Q2 2023-24
Waste Collections	1,267	<b>847</b>
Housing & Communities	934	<b>515</b>
Highways, Traffic & Transport	295	<b>210</b>
Finance	174	<b>101</b>
Customer & Digital Services	142	<b>65</b>
Environmental Enforcement (including Parks & Harbour Authority)	58	<b>34</b>
Education	89	<b>27</b>
Economic Development	63	<b>26</b>
Bereavement & Registration (including Cardiff Dogs Home)	11	<b>16</b>
Planning (including Building Control)	28	<b>11</b>
Governance & Legal Services	8	<b>2</b>
HR	2	<b>2</b>
<b>Total</b>	<b>3,071</b>	<b>1,856</b>

This report does not consider Social Services complaints. Complaints for Social Services are recorded under their statutory complaints procedure. However, a breakdown of the number of complaints received by Social Services can be found below.

Service Area	Number of complaints 2022-23	Number of complaints Q1 & Q2 2023-24
Adult Services	126	<b>62</b>
Children's Services	236	<b>103</b>



## 5. Complaints by area

### Waste Collections

Service Area	2022-23	<b>2023-24 Q1 &amp; Q2</b>
Waste Collections	1,267	<b>847</b>
Number / Percentage of complaints responded to on time	960 (75.8%)	<b>599 (70.7%)</b>

		Total complaints closed within timescales				Complaint outcome	
	Service Area	20 working days	After 20 working days but within 3 months	After 3 months but within 6 months	After 6 months	Upheld	Not upheld
2022-23	Waste Collections	960	286	21	0	1197	70
<b>2023-24 Q1 &amp; Q2</b>		<b>599</b>	<b>248</b>	<b>0</b>	<b>0</b>	<b>745</b>	<b>102</b>

### Environmental Enforcement

Service Area	2022-23	<b>2023-24 Q1 &amp; Q2</b>
Environmental Enforcement	58	<b>34</b>
Number / Percentage of complaints responded to on time	39 (67.2%)	<b>27 (79.4%)</b>

		Total complaints closed within timescales				Complaint outcome	
	Service Area	20 working days	After 20 working days but within 3 months	After 3 months but within 6 months	After 6 months	Upheld	Not upheld
2022-23	Environmental Enforcement	39	19	0	0	43	15
<b>2023-24 Q1 &amp; Q2</b>		<b>27</b>	<b>7</b>	<b>0</b>	<b>0</b>	<b>28</b>	<b>6</b>





## Highways, Traffic & Transportation

Service Area	2022-23	2023-24 Q1 & Q2
Highways, Traffic & Transportation	295	210
Number / Percentage of complaint responded to on time	247 (83.7%)	172 (81.9%)

		Total complaints closed within timescales				Complaint outcome	
	Service Area	20 working days	After 20 working days but within 3 months	After 3 months but within 6 months	After 6 months	Upheld	Not upheld
2022-23	Highways, Traffic & Transport	247	32	13	3	51	244
2023-24 Q1 & Q2		177	33	0	0	11	199

## Planning (including Building Control)

Service Area	2022-23	2023-24 Q1 & Q2
Planning (including Building Control)	28	11
Number / Percentage of complaint responded to on time	7 (25.0%)	7 (63.6%)

		Total complaints closed within timescales				Complaint outcome	
	Service Area	20 working days	After 20 working days but within 3 months	After 3 months but within 6 months	After 6 months	Upheld	Not upheld



2022-23	Planning (including Building Control)	7	17	2	2	0	28
<b>2023-24 Q1 &amp; Q2</b>		<b>7</b>	<b>3</b>	<b>1</b>	<b>0</b>	<b>1</b>	<b>10</b>

## Bereavement & Registration

Service Area	2022-23	2023-24 Q1 & Q2
Bereavement & Registration	11	15
Cardiff Dogs Home	0	1
Number / Percentage of complaints responded to on time	11 (100%)	16 (100%)

	Service Area	Total complaints closed within timescales				Complaint outcome	
		20 working days	After 20 working days but within 3 months	After 3 months but within 6 months	After 6 months	Upheld	Not upheld
2022-23	Bereavement & Registration	11	0	0	0	6	5
<b>2023-24 Q1 &amp; Q2</b>		<b>15</b>	<b>0</b>	<b>0</b>	<b>0</b>	<b>13</b>	<b>2</b>
2022-23	Cardiff Dogs Home	0	0	0	0	0	0
<b>2023-24 Q1 &amp; Q2</b>		<b>1</b>	<b>0</b>	<b>0</b>	<b>0</b>	<b>0</b>	<b>1</b>

## Education & Lifelong Learning

Service Area	2022-23	2023-24 Q1 & Q2
Education	89	<b>27</b>
Number / Percentage of complaints responded to on time	74 (83.1%)	<b>22 (81.5%)</b>

	Service Area	Total complaints closed within timescales				Complaint outcome	
		20 working days	After 20 working days but within 3 months	After 3 months but within 6 months	After 6 months	Upheld	Not upheld
2022-23	Education	79	10	0	0	9	80
<b>2023-24 Q1 &amp; Q2</b>		<b>22</b>	<b>5</b>	<b>0</b>	<b>0</b>	<b>7</b>	<b>20</b>

## Economic Development (including Parks & Harbour Authority)

Service Area	2022-23	2023-24 Q1 & Q2
Economic Development (including Parks & Harbour Authority)	63	<b>26</b>
Number / Percentage of complaints responded to on time	50 (79.4%)	<b>22 (84.6%)</b>

	Service Area	Total complaints closed within timescales				Complaint outcome	
		20 working days	After 20 working days but within 3 months	After 3 months but within 6 months	After 6 months	Upheld	Not upheld
2022-23	Economic Development	50	13	0	0	29	34
<b>2023-24 Q1 &amp; Q2</b>	(including Parks & Harbour Authority)	<b>22</b>	<b>4</b>	<b>0</b>	<b>0</b>	<b>11</b>	<b>15</b>



## Revenues

Service Area	2022-23	<b>2023-24 Q1 &amp; Q2</b>
Revenues	174	<b>101</b>
Number / Percentage of responses sent within 20 working days	173 (99.4%)	<b>101 (100.0%)</b>

		Total complaints closed within timescales				Complaint outcome	
	Service Area	20 working days	After 20 working days but within 3 months	After 3 months but within 6 months	After 6 months	Upheld	Not upheld
2022-23	Revenues	173	1	0	0	46	128
<b>2023-24 Q1 &amp; Q2</b>		<b>101</b>	<b>0</b>	<b>0</b>	<b>0</b>	<b>23</b>	<b>78</b>

## Governance & Legal

Service Area	2022-23	<b>2023-24 Q1 &amp; Q2</b>
Governance & Legal	8	<b>2</b>
Number / Percentage of responses sent within 20 working days	8 (100%)	<b>2 (100%)</b>

		Total complaints closed within timescales				Complaint outcome	
	Service Area	20 working days	After 20 working days but within 3 months	After 3 months but within 6 months	After 6 months	Upheld	Not upheld
2022-23	Governance & Legal	8	0	0	0	1	7
<b>2023-24 Q1 &amp; Q2</b>		<b>2</b>	<b>0</b>	<b>0</b>	<b>0</b>	<b>0</b>	<b>2</b>



## Customer & Digital Services

Service Area	2022-23	<b>2023-24 Q1 &amp; Q2</b>
Customer & Digital Services	142	<b>65</b>
Number / Percentage of responses sent within 20 working days	124 (69.3%)	<b>63 (96.9%)</b>

	Service Area	Total complaints closed within timescales				Complaint outcome	
		20 working days	After 20 working days but within 3 months	After 3 months but within 6 months	After 6 months	Upheld	Not upheld
2022-23	Connect to Cardiff (C2C)	43	0	0	0	29	14
<b>2023-24 Q1 &amp; Q2</b>		<b>24</b>	<b>0</b>	<b>0</b>	<b>0</b>	<b>15</b>	<b>9</b>
2022-23	Rent Smart Wales	76	20	0	0	77	19
<b>2023-24 Q1 &amp; Q2</b>		<b>38</b>	<b>2</b>	<b>0</b>	<b>0</b>	<b>22</b>	<b>18</b>
2022-23	24/7 Services	3	0	0	0	0	3
<b>2023-24 Q1 &amp; Q2</b>		<b>1</b>	<b>0</b>	<b>0</b>	<b>0</b>	<b>1</b>	<b>0</b>



## Housing & Communities

Service Area	2022-23	<b>2023-24 Q1 &amp; Q2</b>
Housing & Communities	934	<b>515</b>
Number / Percentage of complaints responded to on time	32 (3.4%)	<b>324 (62.9%)</b>

	Service Area	Total complaints closed within timescales				Complaint outcome	
		20 working days	After 20 working days but within 3 months	After 3 months but within 6 months	After 6 months	Upheld	Not upheld
2022-23	Housing	32	283	613	6	326	608
<b>2023-24 Q1 &amp; Q2</b>		<b>324</b>	<b>186</b>	<b>5</b>	<b>0</b>	<b>182</b>	<b>333</b>





**STRONGER  
FAIRER  
GREENER**



# **Governance & Audit Committee – Corporate Complaints – 23<sup>rd</sup> January 2024**



**#GweithioDrosGaerdydd  
#GweithioDrosochChi**

**#WorkingForCardiff  
#WorkingForYou**

# Background



STRONGER  
FAIRER  
GREENER



- In addition to the Council’s annual complaints report, we produce a mid-year report at the six – month period. This report details the Council’s performance when handling complaints over Quarters 1 and 2 and provides us with an opportunity to ‘take stock’.
- The number of complaints recorded by Cardiff Council for the first six months of 2023/24 was 1,856.
- Though this is for only six months, we can speculate that we will receive more complaints in 2023-24 than in 2022-23. By comparison, 3,071 complaints were recorded in 2022-23.

Page 244



#GweithioDrosGaerdydd  
#GweithioDrosochChi

#WorkingForCardiff  
#WorkingForYou



# Response Times



STRONGER  
FAIRER  
GREENER



- Cardiff Council's Corporate Complaints Policy states that we will aim to respond to complaints within 20 working days.
- If we are not able to respond to complaints within this time, we need to let complainants know about this and when they can expect to receive a response.

Page 245

For the first six months of 2023-24, 73.4% of our complaints received a full response within our corporate timescales (20 working days). This represents a notable increase from 2022-23 when 56% received a response within 20 working days

- A further 26.3% of complainants received a response after 20 working days but within 3 months, leaving just 0.3% who received a response after 3 months but within 6 months.



#GweithioDrosGaerdydd  
#GweithioDrosochChi

#WorkingForCardiff  
#WorkingForYou

# Halo - Reminder



STRONGER  
FAIRER  
GREENER



The key aim of the new Complaints, Compliments and Cabinet & Members Enquiries Management system is to create and embed a centralised, streamlined approach to the management of complaints, members, and cabinet enquiries.

The new system will improve the handling process, increase efficiency, and provide corporate oversight of enquiries across the organisation.

Members of the Committee have been actively involved on this journey since our initial presentation in July 2022 and are well-informed about our imminent launch scheduled for the end of January 2024.

Page 246



#GweithioDrosGaerdydd  
#GweithioDrosochChi

#WorkingForCardiff  
#WorkingForYou

# Halo - Benefits



STRONGER  
FAIRER  
GREENER



Key benefits of the new system are to:

- Provide good quality, consistent responses for all complaints & cabinet & member enquiries.
- Record good quality data and the ability to report quickly and easily on performance (note data is currently recorded in different systems in a variety of ways).
- Have a corporate overview of complaints & cabinet & members enquiries in real time.
- Respond to complaints & cabinet & member enquiries within the required SLAs.
- Improve the complaints & cabinet & member enquiries processes to enable a more joined up way of working by eliminating inefficient processes, such as multiple handovers, double keying, duplication etc. consuming valuable staff time.



# Halo - Update



STRONGER  
FAIRER  
GREENER



- The launch of Cabinet and Member Enquiries (Phase 2 of the project) took place in August 2023 and has been very well received with no significant issues reported.
- The Complaints & Compliments instance is in progress. Significant work has been undertaken in advance of our expected 'go live' date by the end of January 2024.
- There has been significant engagement with stakeholders ahead of this launch.



#GweithioDrosGaerdydd  
#GweithioDrosochChi

#WorkingForCardiff  
#WorkingForYou

# Halo - Update

- Face-to-face training has been made available for service areas to onboard to the new system and the new process for dealing with complaints and enquiries. A user guide has also been created and 11 'how to' videos have been created.

This will be more sustainable rather than delivering ongoing face-to-face training.



STRONGER  
FAIRER  
GREENER



Corporate Complaints, Compliments and  
Enquiries Agents User Guides



#GweithioDrosGaerdydd  
#GweithioDrosochChi

#WorkingForCardiff  
#WorkingForYou



STRONGER  
FAIRER  
GREENER



# Training

In this section you will find several types of training for dealing with written correspondence, including Cabinet and Member Enquiries, with some courses specifically concentrating on efficient complaint handling. Anyone who is in a role where they are required to process, investigate, or respond to complaints are strongly encouraged to complete them.

Courses are bookable via your DigiGOV training calendar or the e-learning pool at Cardiff Council Academy Online. Links and contact details can be found at the bottom of the page. Classroom training is delivered by the Customer Services Trainer through MS Teams with course content created in partnership with the Public Services for Wales Ombudsman.

For questions on course content or availability, please contact Customer Services Trainer [Jodie Williams](#)

### Training Courses

Training Course	Duration	Who	Content	Delivery Method	Booking Method
Written Communication	1 Hour	Council Wide	Training covers best practice and aims to develop consistency for written skills in responding to complaints and enquiries to citizens, including how to deal with Welsh correspondence.	E-learning	Cardiff Academy
Handling Complaints	3.5 Hours	All staff	Training is in collaboration with the Ombudsman and covers what complaints are, why complaints are important and why do people complain. Includes information on the process of dealing with a complaint and the difference between a complaint/service request.	TBC	TBC
Investigation of Complaints	3.5 Hours	Responders, Approvers & Authorisers	Training is in collaboration with the Ombudsman and covers complaint handling in further detail for those who actively deal/responds to complaints. Course also includes investigation skills, evidence gathering, decision making	TBC	TBC



#GweithioDrosGaerdydd  
#GweithioDrosochChi

#WorkingForCardiff  
#WorkingForYou



# Halo - Update



STRONGER  
FAIRER  
GREENER



- The Project Team have had several run-throughs of the system with end-to-end tickets, all has been reported to work well.
- Review workshops have taken place with teams involved with Phase 2 (enquiries). There has been significant stakeholder involvement with the majority of officers involved with Phase 2 (enquiries) expected to be involved with Phase 3 (complaints) also.
- Regular project updates have taken place with Operational Managers, Senior Managers (the 'approvers') regarding their responsibilities and to encourage 'buy-in'
- Project Manager has also met separately with some Operational Managers to establish certain needs.



# Halo Update – Sharepoint site is live



**STRONGER  
FAIRER  
GREENER**



Corporate Complaints, Compliments and Members Enquiries

[Home Page](#)

[Training](#)

[Getting Started](#)

[Documents & Information](#)

[Frequently Asked Questions](#)

...

[Edit](#)

☆ Not following

🔗 Share

+ New ⚙️ Page details 📊 Analytics

Published 9/5/2022 ✎ Edit ↗

Page 252

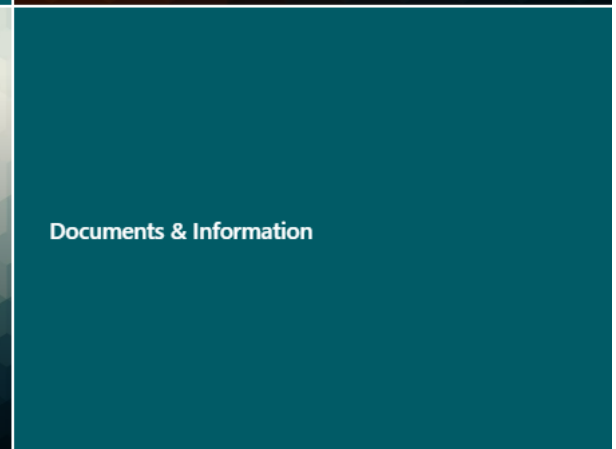
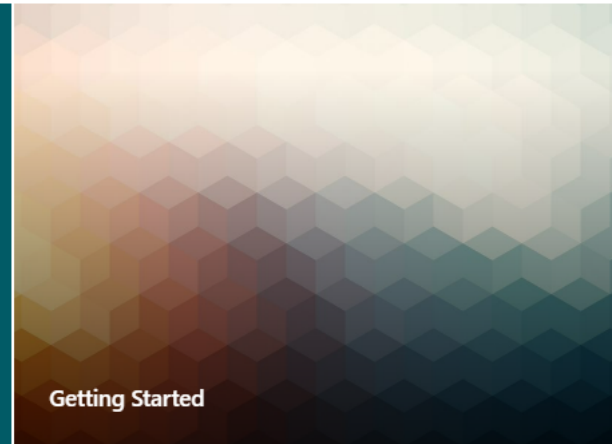
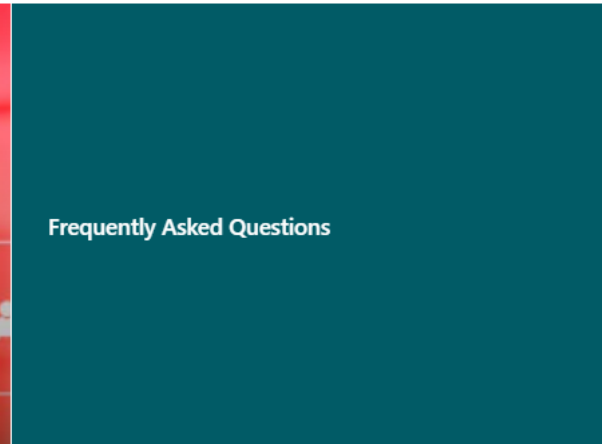

Welcome to the Corporate Complaints, Compliments, Cabinet and Member Enquiries site where you will find information to assist you and your team with complaints, compliments and enquiries.



## Complaints & Compliments Area

### A complaint is:

'An expression of concern or dissatisfaction made by one or more members of the public in regard to Cardiff Council's actions, or lack of action, or the standard of service it provided following an initial request for service.'

This can be expressed by any available communication method.

### A complaint is not:

- A first-time report of an occurrence that needs Cardiff Council's attention or an initial request for service
- A formal review or appeal against a decision
- A way of asking for a change to legislation or a policy decision
- A means for lobbying groups/organisations to promote a cause
- A general expression of dissatisfaction that does not relate specifically to Cardiff Council's actions, or lack of action, or the standard of service it provided.

For further information about how to deal with complaints please visit the [Standard Operating Procedure](#)

### A compliment is:

'An expression of praise to the Council or any member of Council staff. It could include an occasion where assistance given by a staff member was above and beyond the standard expected, or a service provided exceeded expectations.'

When a compliment is received the Council should record it so that it can be shared with the relevant manager and member of staff.

The **Corporate Complaints Team** (Rory Williams and Claire Lowdon) can assist with queries about complaints and compliments. Among the duties and responsibilities of the team are to:

- Liaise with and advise service areas who require support when dealing with customer complaints.
- Collate, monitor and report on complaints received for the Council, and to produce the Council's Annual Complaints Report.
- Act as the point of contact for customers who have displayed 'unacceptable behaviour' as outlined in our 'Unacceptable Actions by Customers' policy (previously known as Persistent & Vexatious).
- Act as the link between the Council and Public Services Ombudsman for Wales.

Following the introduction of Halo, the team will look to ensure that all service areas are adhering to the Council's Complaints Policy in terms of acknowledging and responding in full within the set timescales.

Our policy states that we will formally acknowledge a complainant's concerns within 5 working days and that we aim to resolve concerns as quickly as possible - expecting to deal with the vast majority within 20 working days.

If you would like further information about the Corporate Complaints Team, the Ombudsman, or complaints in general, please contact us using the e-mail address below.

#### Quick Links

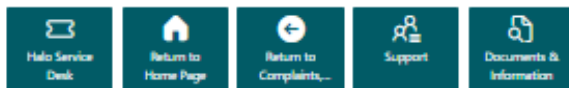

#### Corporate Complaints & Compliments Contact email

 Corporate Complaints Team / Tim Cwynion Co...



**STRONGER  
FAIRER  
GREENER**



## Documents & Information

### Standard Operating Procedures



Corporate Complaints Standard Operating Procedure



Cabinet Correspondence Standard Operating Procedure



Member Enquiries Service (MES) Standard Operating Procedure



Ombudsman Standard Operating Procedure

### Policies



Welsh Complaints Policy



Social Services Complaints Policy and Procedure



Guide to handling complaints and representations by LA social...



Complaints Policy

### Useful Documents



Letter Privacy Disclaimers & Footers(English & Welsh) July 2022

<b>Audit Title:</b>	<b>Complaints and Compliments Audit</b>
<b>Audit Assurance:</b>	<b>Effective with opportunity for improvement</b>

REF	RECOMMENDATIONS	RISK RATING	MANAGEMENT RESPONSE	RESPONSIBLE OFFICER	ACTION DATE (dd/mm/yyyy)
1	<p>A "Terms of reference" should be formalised for the corporate complaints officer meetings, and the meetings should be re-established and re-scheduled with an agenda and minutes taken. The meetings should be comprising Complaints Officers from each directorate, the Corporate Complaints Officer, and at times a representative from the Council's Internal Audit Section and meet at least quarterly.</p> <p>NB - The meetings should be chaired by the corporate team and meet at least quarterly to discuss the complaints data, timescales, and reporting procedures. This should be done for oversight and to support the work of complaints officers in each directorate, where officers could learn from the Complaints "Group" and receive peer support. These meetings should help provide more in-depth information and analysis on all aspects of the complaints data and its relevancy to the service areas within the directorates and is proposed in accordance with good practice.</p>	Red / Amber	Quarterly meetings re-established with first session having been completed on 26.04.23 as chaired by Corporate Complains and Correspondence Manager with minutes available. Further booked on a rolling quarterly basis. As a standard Agenda item, stats gathered across the relevant 3 month period will be shared with the group to allow best practise discussions to take place for peer to peer support as well as group discussion being led by Corporate Complaints team	Lowri Morris	COMPLETE
2	The Corporate complaints advisory Team should update the SOP with the new complaints definition and contact directorates and discuss their interpretation of what should be recorded as a complaint, to support consistent application of the policy across the Council.	Amber / Green	Corporate Complaint SOP has latest CC complaint definition as signed off at HALO Board. This has the addition of identifying what 'is not a complaint'. SOP with this definition circulated to Complaints Coordination officers and accessible at any time via CC's CIS system. Corporate Complaint Team available in advisory capacity as to definition of citizen contact as and when needed as advised in coordinators meeting.	Lowri Morris	COMPLETE
3	It is recommended that to assess the authority's ability to oversee compliments and complaints effectively and efficiently, all efforts should be made to get the HALO system implemented within set timescales and rolled out Council wide.	Amber / Green	Roadmap of service rollout amended in line with project resource availability with the Corporate Complaints iteration planned to go live in January 2024 after all necessary actions in the planning and implementation phases are finalised using any lessons learned from the pilots in Cabinet and Members Enquiries	Isabelle Bignall	31.01.2024

REF	RECOMMENDATIONS	RISK RATING	MANAGEMENT RESPONSE	RESPONSIBLE OFFICER	ACTION DATE (dd/mm/yyyy)
4	Following the roll-out of HALO, a quality assurance system should be developed centrally on compliance and the efficiency and effectiveness of complaints handling, through the use of the data in HALO and its available applications and opportunities for data and case interrogation.	Amber / Green	It will remain Service Area responsibility to record all necessary data on HALO and manage response deadlines but the overview HALO affords will allow the Corporate Complaint team to act on any concerning data and (as per quality KPI) carry out randomised dip sampling of responses as they will be stored centrally. Target date reflects the planned HALO roll out for Corporate Complaints and the need to inbuild a bedding-in period given the scope of change that impacts all areas of the authority and the creation of a quality monitoring criteria with input from complaint coordinators	Lowri Morris	31.03.2024

REF	RECOMMENDATIONS	RISK RATING	MANAGEMENT RESPONSE	RESPONSIBLE OFFICER	ACTION DATE (dd/mm/yyyy)
5	<p>It is recommended that the Governor services Team produce a briefing note and add the following advice to their termly checklist and share it with all schools and Governing bodies in Cardiff. The briefing note should:</p> <ul style="list-style-type: none"> <li>•Request that each headteacher produces an annual report to the governing body about all complaints made to the school, so that the governing body can monitor complaints and consider how to improve procedures or address issues that generate complaints. This could be a separate targeted report to the governing body or covered as an item within the headteachers report.</li> <li>•Suggest that the report records the number of complaints, whether made by adults or pupils, and that the headteacher also reports to the governing body any related matters considered by the school council.</li> <li>•Advise schools to keep records of complaints for the current year plus 6 years for major complaints and if negligence was involved current year plus 15 years and if child protection issues were identified, current year plus 40 years.</li> <li>•Recommend that record keeping is reviewed in all schools to ensure that complaints are logged in a central place. This will enable the Headteacher and Governing Body to have improved oversight and to identify recurring issues or support needed.</li> </ul>	Amber / Green	<ul style="list-style-type: none"> <li>•The spring and summer term checklists sent to all Chairs of Governors, Headteachers and Clerks to Governors included an action for governing bodies to review their complaints procedures in accordance with revised Welsh Government guidance and model policy. A further reminder will be sent in the autumn term followed by an audit by the Governor Services Team in the summer term.</li> <li>•The summer term checklist sent to all Chairs of Governors, Headteachers and Clerks asked governing bodies to ensure procedures are in place to log school complaints and that Headteacher reports provides governors with key data relating to complaints.</li> </ul> <p>Governor Services will work with Internal Audit to add some response requirements to the next CRSA which could be followed up in the event of any concern.</p> <ul style="list-style-type: none"> <li>•A full briefing note will be produced for the autumn term notifying governing bodies of the need for regular reporting and record keeping of complaints. The guidance will include the retention periods for complaints as detailed in the Information and Records Management Toolkit for Schools. The briefing note will form part of a wider piece of work on complaints that will also include the issue of a model 'Unacceptable Actions Policy for Governing Bodies to consider adopting. Again, Governor Services will work with Internal Audit to add some response requirements to the next CRSA which could be followed up in the event of any concern.</li> </ul>	Governor Services Manager	31/03/2024

This page is intentionally left blank

---

**GOVERNANCE & AUDIT COMMITTEE: 23 JANUARY 2024**

---

**MID-YEAR ASSESSMENT OF PERFORMANCE 2023/24****REPORT OF THE HEAD OF PERFORMANCE AND PARTNERSHIPS****AGENDA ITEM: 8.2**

---

**Reason for this Report**

1. For Governance and Audit Committee to receive for noting the Council's Mid-Year Assessment Report 2023/24, in advance of it discharging the following responsibility when the report for the full year is prepared:
  - To review the Council's draft annual Self-Assessment Report, and make any appropriate recommendations for changes.

**Background**

2. As part of its planning and performance arrangements the Council is required to publish an end-of-year self-assessment of performance (which is integrated within the Annual Wellbeing Report). The Governance and Audit Committee is required under the Local Government and Elections (Wales) Act 2021 to review the Council's statutory annual Self-Assessment Report and make any appropriate recommendations. The Committee reviewed the Council's last annual self-assessment report (within its Annual Wellbeing Report 2022/23) on 11<sup>th</sup> July 2023 and made no recommendations for improvement.

**Issues**

3. As part of the Council's strengthened performance management arrangements, a mid-year self-assessment of performance is also published annually. This ensures that performance is kept under regular review, there is collective understanding of progress, as well as areas of challenge, and corrective action can be identified and agreed if necessary.
4. The Governance and Audit Committee has agreed to receive the non-statutory draft Mid-Year Self-Assessment Report, to note the findings and consider the self-assessment process for developing the report.

## **Mid-Year Self-Assessment Report**

5. The Mid-Year Self-Assessment report provides an assessment of performance for each of the Council's seven Well-Being Objectives, as set out in the Corporate Plan 2023-26.
6. The [Cabinet Report of 14 December 2023](#) (Appendix A) sets out the self-assessment process for developing the Mid-Year Performance Assessment and the evidence upon which the report's conclusions are based. The report summarises areas of progress and improvement, and also identifies a small number of strategic improvement priorities which will be the subject of focus during Quarter 3 and Quarter 4 of 2023/24. These are:
  - a. Financial Pressures
  - b. Demand Pressures across Council Services
  - c. Workforce Pressures impacting all Council Services
  - d. Responding to new risks and issues
7. The Mid-Year Self-Assessment Report was considered by the Council's Cabinet on 14<sup>th</sup> December 2023.
8. The Council's Policy Review and Performance (PRAP) Scrutiny Committee considered the Mid-Year Assessment of Performance 2023/24 at its meeting on 13<sup>th</sup> December 2023. The Committee made two recommendations, both of which were accepted.
9. The report was also considered by the Council's Performance Panel on 28<sup>th</sup> November 2023, which includes all Scrutiny Committee Chairs. The Panel made 11 recommendations, 10 of which were accepted in full and one which was partially accepted. Responses were provided to all requests by the Panel for further information.
10. A copy of the Cabinet Report, Mid-Year Self Evaluation Report, Scrutiny Letter and Cabinet Response can be accessed below:
  - [Cabinet Report](#)
  - [Mid-Year Assessment Report](#)
  - [Scrutiny Performance Panel Letter](#)
  - [Scrutiny Performance Panel Letter Response](#)
  - [PRAP Scrutiny Letter](#)

## **Legal Implications**

11. Relevant legal provisions are set out in the body of the report. There are no direct legal implications arising from the recommendations of the report.

## **Financial Implications**

12. There are no financial implications directly arising from this report.



## RECOMMENDATION

The Committee is recommended to:

1. Note the contents of the Mid-Year Self-Assessment Report (Appendix B);

**Gareth Newell**

**Head of Performance and Partnerships**

17 January 2024

## Appendices

- **Appendix A: Mid Year Self-Assessment** [Cabinet Report \(14 December 2023\)](#)
- **Appendix B:** [Mid-Year Self-Assessment Report \(2023/24\)](#)

## Background Papers

- Year End Wellbeing (Self-Assessment) Report 2022/23 (considered by Governance and Audit Committee on [11<sup>th</sup> July 2023](#), agreed by Cabinet on [13<sup>th</sup> July 2023](#) and agreed by Council on [21<sup>st</sup> September 2023](#)).

This page is intentionally left blank



## **GOVERNANCE & AUDIT COMMITTEE: 23 JANUARY 2024**

---

### **GOVERNANCE SENIOR MANAGEMENT ASSURANCE STATEMENT 2022/23**

#### **REPORT OF CORPORATE DIRECTOR RESOURCES AGENDA ITEM: 9.1**

---

##### **Reason for Report**

1. The Governance and Audit Committee's Terms of Reference requires Members to review the Annual Governance Statement prior to approval and consider whether it properly reflects the risk environment and supporting assurances, taking into account the internal audit opinion on the overall adequacy and effectiveness of the Council's framework of governance, risk management and internal control.
2. Specific components of the AGS reported individually to the Governance and Audit Committee are the biannual Senior Management Assurance Statements (SMAS) and the AGS Action Plan of significant governance issues, following approval by the Senior Management Team.

##### **Background**

3. Senior Management Assurance Statements (SMAS) are used to assess governance maturity in application of the 'Delivering Good Governance in Local Government' framework, developed by CIPFA / SOLACE.
4. Through the SMAS, each Director responds to 25 good governance statements using a 5-point maturity scale for their areas of responsibility ranging from 'not in place', 'limited application', 'mixed application', 'strong application' to 'embedded'. Prior to submitting their returns, each Director is required to obtain underlying assurances from their management teams to support a directorate-wide response to each statement.

##### **Issues**

###### Senior Management Statement

5. The 2022/23 process operated within the context of Council funding levels not keeping up with the increasing demand on some Council services and the need to accommodate rising cost pressures.
6. The attention of Senior Officers has been firmly focussed on effective delivery of services underpinned by communication, decision making and control whilst operating in an environment which fluctuated and changed throughout the year.
7. Whilst there were pressing challenges throughout the year, the Senior Management Team continued to engage with the previous senior management assurance process in

full. Each directorate undertook a Half-yearly self-assessment in November 2022 and a final assessment in May 2023. The Chief Executive held Challenge Sessions with each directorate in order to consider the merits of the self-assessment, the progress made and identify any areas of concern. These comments helped to inform the Senior Management Statement which is included in the Annual Governance Statement.

#### Annual Governance Statement (AGS)

8. The AGS (see Appendix A) includes Statements from the Audit Manager, Governance and Audit Committee and Senior Management respectively. The Senior Management Team has in its considerations determined that two of the three recommendations were to be taken forward to the year 2023/24 with one recommendation considered complete. The progress on the actions are set out below with the rationale for either closing the action or taking it forward into 2023/24
9. **Extend and deepen the areas of SMT investigation in respect to compliance, risk and outcomes. – CLOSED** The challenge of delivering services with increased demand and less available financial resources has highlighted the importance of compliance areas being reported and considered at Senior management level. This action was proposed to be closed as it now forms part of the working model going forward. Regular reports on individual directorates have been considered and discussed at SMT level on areas such as Service delivery issues, Safeguarding, Risk, Procurement, Sickness Absence, Performance Reviews and Internal Audit recommendations have been received during the year. Data has accompanied reports that enable SMT to identify areas of improvement and to ensure that progress where needed is achieved.
10. **Extend the assurance on the quality of performance reviews through evidence gathering at Directorate level. – Taking forward to 2023/24-** SMT have regularly received reports on compliance on Performance reviews. The Directorate delivery plans continue to be the source of personal and team objectives although it continues to be acknowledged that this is not the case at all levels due to the scope and scale of some directorates. The quality of performance reviews remains an area where further improvements are required to ensure that this is fully embedded throughout individual directorates.
11. **Embed into the self- assessment on Assurance the Five ways of Working in respect to the Future Generations Act. – Taking forward to 2023/24 -** The Self-Assessment on assurance has been amended to include a specific set of questions which covered the Five ways of Working in respect to the Future Generations Act. The Directorates have tested themselves against these objectives for the period of 2022/23 but there was a need to keep this action for 2023/24 to ensure sustainable improvement has been made across all directorates.

#### Reason for Recommendation

12. To enable the Governance and Audit Committee to review and comment upon the self-assessed elements of the AGS.

#### Legal Implications

13. There are no direct legal implications arising from this report.

#### Financial Implications

14. There are no direct financial implications arising from this report.

### **Recommendation**

15. The Governance and Audit Committee to review and comment upon the Annual Governance Statement, namely, the resulting overall 'Senior Management Statement' and 'Action Plan of Significant Governance Issues'.

**Christopher Lee**  
**Corporate Director Resources**  
January 2024

The following Appendices are attached:

**Appendix A** - Annual Governance Statement 2022/23

This page is intentionally left blank

# **Cardiff Council**

# **Draft Annual Governance**

# **Statement 2022/23**

## CONTENTS

<b>Scope of Responsibility</b>	<b>page 3</b>
<b>Purpose of the Framework</b>	<b>page 3</b>
<b>The Governance Framework</b>	<b>page 4</b>
<b>Assessment Process and Summary</b>	<b>page 4</b>
<b>Assurance Statements</b>	<b>page 5</b>
• <b>Senior Management Statement</b>	<b>page 5</b>
• <b>Audit Manager Statement and Annual Opinion</b>	<b>page 7</b>
• <b>Governance and Audit Committee Statement</b>	<b>page 9</b>
<b>Governance Framework: supporting information</b>	<b>page 12</b>
<b>Annual Governance Statement Action Plan</b>	<b>page 29</b>
<b>Cardiff and the Vale of Glamorgan Pension Fund</b>	<b>page 30</b>
<b>Certification</b>	<b>page 30</b>



## Scope of Responsibility

1. Cardiff Council (the Council) is responsible for ensuring that its business is conducted in accordance with the law and proper standards, and that public money is safeguarded and properly accounted for, having regard to a combination of economy, efficiency and effectiveness. In discharging this overall responsibility, the Council is responsible for putting in place proper arrangements for the governance of its affairs, and facilitating the effective exercise of its functions, including arrangements for the management of risk.
2. The Council is responsible for the Cardiff Harbour Authority. The Council is also the Administering Authority for the Cardiff and Vale of Glamorgan Pension Fund (the Pension Fund) and Cardiff Port Health Authority (CPHA) and is the Accountable Body for the Cardiff Capital Region (CCR) City Deal. Cardiff Council has five wholly owned subsidiary companies three of which actively traded in 2022/23, the significant one being Cardiff City Transport Services Ltd. (Cardiff Bus). The Council also has an interest in a special purpose vehicle (CSC Foundry Limited) which is governed by a Joint Committee for the CCR City Deal.
3. The governance arrangements detailed in this Annual Governance Statement (AGS) are documented in consideration of the Council's areas of responsibility, and the extent to which the Council is charged with governance.
4. The Council has adopted the 'Delivering Good Governance in Local Government' framework, developed by the Chartered Institute of Public Finance and Accountancy (CIPFA) and the Society of Local Authority Chief Executives and Senior Managers (SOLACE). This statement explains how the Council has complied with the Governance Framework and meets the requirements of the Accounts and Audit (Wales) Regulations 2014, as amended by the Accounts and Audit (Wales) (Amendment) Regulations 2018.

## The Purpose of the Governance Framework

5. The Governance Framework comprises the systems, processes, culture and values by which the Council is directed, controlled, and the means through which it accounts to, engages with, and leads the community. It enables the Council to monitor the achievement of its strategic objectives and to consider whether those objectives have led to the delivery of appropriate, cost-effective services. The Council's Constitution sets out how decisions are made and the procedures which are followed through rules, codes of practice and protocols.
6. The system of internal control is a significant part of the framework and is designed to manage risk to a reasonable level. It cannot eliminate all risk of failure to achieve policies, aims and objectives but is based on an ongoing process to identify, prioritise and appropriately manage risk.
7. The Code of Corporate Governance documents how we apply the principles of good governance (as summarised in Section 4 of the AGS – Assessment

Process and Summary). This Code can be found within the Council Constitution (Part 5) and was last ratified in July 2023.

## **The Governance Framework**

8. The Framework comprises two core principles and five supporting principles. Principles A and B run through principles C to G, but good governance is dynamic, and the Council is committed to improving governance on a continuing basis through a process of evaluation and review.

### ***Core principles:***

- A. Behaving with integrity, demonstrating strong commitment to ethical values, and respecting the rule of law
  - B. Ensuring openness and comprehensive stakeholder engagement
- Supporting Principles:

### Supporting principles

- C. Defining outcomes in terms of sustainable economic, social, and environmental benefits
- D. Determining the interventions necessary to optimise the achievement of the intended outcomes
- E. Developing the entity's capacity, including the capability of its leadership and the individuals within it
- F. Managing risks and performance through robust internal control and strong public financial management
- G. Implementing good practices in transparency, reporting, and audit to deliver effective accountability

## **Assessment Process and Summary**

9. The AGS summarises the assessment of governance against the governance framework and comprises three elements:
  - Statements from Senior Management, the Audit Manager and the Governance and Audit Committee (the 'Audit Committee' was renamed 'Governance and Audit Committee' following the financial year-end in accordance with the provisions of the Local Government and Elections (Wales) Act 2021. Its opinion was provided following the financial year-end)
  - Supporting analysis mapped to the core and supporting good governance principles that provides a judgement that is based on supporting information and evidence
  - A Senior Management judgement of the Council's significant governance issues

10. These three elements when taken together represent the assessment of governance, through the perspectives of the Senior Management Team (SMT) and the independent opinions of the Internal Audit Manager and the Governance and Audit Committee based on their respective programmes of work and an assessment of the system of internal control.
11. For further information and detail, supporting information is mapped to the governance framework principles (A-G) within the AGS, and followed by an open disclosure from the SMT of the significant governance issues affecting the organisation as summary actions to take forward and address.

The diagram in fig. 1 sets out the components of this assessment.

**Fig.1**



**Assurance Statements**

12. The following statements are made at the year-end, having given consideration of the performance information, governance disclosures and audit and regulatory report findings from assessors both internal and external to the Council.

**Senior Management Statement**

13. The set of senior management assurance statements are used a core measurement of assurance on good governance within each directorate and for the Council overall

14. As a Senior Management Team, we have undertaken a review of the self-assessment exercise to maintain assurance that the areas of consideration remain the right areas to judge the organisation upon and to address the identified actions arising from last year's AGS relating to Compliance, Risk, Performance reviews and Five ways of working. This review identified that there was a need to change the focus of some statements to effectively capture the emphasis of Partnership working and engagement and equalities. Within the assurance process. Over the year, the nine broad categories for consideration are Risk, Partnership Working, Engagement and Equalities, Compliance, Project initiation, Budget, Planning & Performance, Control and Fraud.
15. We continue to apply the self-assessment exercise as a primary means of measuring our delivery of good governance and this has been supplemented this year by each Directorate having an action plan which identifies the key areas of improvement. There continue to be Challenge sessions chaired by the Chief Executive through which consideration is given to the current assurance position for each Directorate.
16. Our good governance assessment exercise has been undertaken during a period of economic uncertainty and significant spikes in both demand for our services not least in Social Care and Education and inflationary increases in both pay and in particular the energy, food and building sectors. We, as a Senior Management Team continue to ensure that the self-assessment exercise reflects the current reality of service delivery so that any matters or improvement actions are captured.
17. The Senior Management Team has continued to meet on average twice on a weekly basis. There were times during 2022/23 that the Senior management Team met more regularly to ensure that there was a swift, corporate, appropriate and measured response to any pressing issues. The focus of these meetings throughout the year has been to ensure that resources are used appropriately, outcomes delivered, and controls remain in place or amended to reflect the environment of the time.
18. The Senior Management Team has engaged with the self-assessment assurance process for 2022/23. The Senior Management Team took the opportunity to review the 2022/23 half yearly and end of year position and considered the body of work delivered over the last six months in the context of the uncertain economic environment.
19. The Senior Management Team considers that the 2022/23 end of year Senior Management Assurance Statement offers a true and fair reflection of the governance maturity of the Council for the year overall. This end of year assessment was based on the governance maturity which we could evidence within each Directorate against the half year position, the performance against individual directorate action plans and identifying any change in position.
20. Accordingly, the Senior Management Team considers that despite the challenging external environment the Council is approaching strong application of good governance across the assurance areas, with some examples of

embedded and limited in some assurance areas in some directorates. This assessment was based on a self-assessment using a 5-point rating system ranging from 'not in place', 'limited application', 'mixed application', 'strong application' to 'embedded'.

21. This assessment has highlighted opportunities to further build on the three SMT Actions set out in last year's Annual Governance Statement. We recognise improvements have been made in the areas of performance, compliance and the way we work but believe further improvement can be made. We continue to survey the assurance landscape and look for any weaknesses that need to be addressed through robust recovery procedures as well as looking to improve areas of strength. The Senior Management Team recognises that it is faced with a period of prolonged uncertainty both in terms of service recovery and responding to increased and different levels of demand across the spectrum of services offered. To support these aims it remains a priority to both implement actions for improvement and to retain a focus on needing to prioritise actions for enhancement to enable strong evidence of application across all areas going forward.
22. In relation to the work of the Senior Management Team in 2022/23 we continued to collectively own the Corporate Risk Register, we reviewed all corporate risks quarterly, and monitored progress against the action plan of significant governance issues.
23. The Chief Executive continues to emphasise that areas of weakness need to be addressed. As noted, the last couple of years have presented great challenge and uncertainty and this will continue for the forthcoming period thus underlying the importance of maintaining the achievement of consistent standards of governance and control across all directorates.

#### **Audit Manager Statement and Annual Opinion 2022/23 (PSIAS Standard 2450)**

24. The Public Sector Internal Audit Standards (PSIAS) state that the 'Chief Audit Executive must deliver an annual internal audit opinion and report that can be used by the organisation to inform its governance statement.' This must be based upon an objective assessment of the framework of governance, risk management and control. It must also include an evaluation of the adequacy and effectiveness of controls in responding to risks within the governance, operations and information systems.
25. This opinion has been prepared by the Audit Manager (Chief Audit Executive for the purpose of the PSIAS), based on the provisions of the PSIAS. In preparing and forming this opinion, a number of sources of information, assurance and insight have been taken into account, including:
26. **Assurance Audit Engagements** – The risk-based annual audit plan has been delivered through an approach to maximise assurance and added value. The audit plan is responsive to risk and informed by audit information and existing assurances, information from Senior

Management, monitoring of Council activity, strategy, risks, and wider assurance sources. For all audits, current risks, pressures and priorities continue to inform the audit scope and testing.

27. **Consultancy Audit Engagements** - The Internal Audit Team provides insight and guidance on areas of control during process development / change. It has continued to provide advice and guidance on the design and implementation of effective controls in the administration of Welsh and Central Government grant schemes such as the Homes for Ukraine Scheme, to achieve compliance and control, and arrangements for the effective prevention and detection of fraud.
28. **Discussion with Senior Managers** – There have been quarterly relationship manager meetings with Directors or their representatives, Audit Manager attendance at Senior Management Team meetings where assurance items have been considered, and regular meetings with the Chief Executive and Corporate Director Resources (Section 151 Officer).
29. **Risk & Governance Reviews** – Risk Registers and Senior Management Assurance Statements which underpin the Council's Annual Governance Statement are subject to regular audit review, and assurance audit engagements.
30. Based on the programme of audit work undertaken to assess the framework and application of governance, risk management and control, the annual opinion for 2022/23 is **effective with opportunity for improvement**. This opinion is based on the delivery of a sufficient Audit Plan, and with an acknowledgment of the significant pressure on Council resources in both demand and budgets, which has been managed through a resilient performance culture.
31. The audit opinion comprises assessments of governance, risk management and control, and includes an evaluation of the adequacy and effectiveness of controls in responding to risks within the governance, operations and information systems.
32. Reviews have been completed in all planned fundamental system areas.
33. In accordance with an approach communicated to the Governance and Audit Committee, the majority of corporate governance audit engagements were completed during the year, supported by a spread of directorate-level assurance audit engagements.
34. Corporate risk management arrangements have been maintained during the year, and a review of directorate risk management has been completed and has reported that there is an appropriate level of risk management maturity in operation at directorate levels.
35. The Council has continued to administer emergency relief, grant payments and support services on behalf of the Welsh and Central

Government, and the Internal Audit and Investigation Teams have advised management on the design of systems and counter-fraud checks in accordance with scheme requirements.

36. The control environment for core financial systems was sufficient, and the majority of audits overall (87%) were allocated an opinion of 'effective' or 'effective with opportunity for improvement'. Eight audits have been given an audit opinion of 'insufficient with major improvement needed' recognising the need for attention to achieve sound controls, and one audit (in respect of the Central Transport Service) was given an 'unsatisfactory' opinion.
37. Audit assurance and support continues to target and follow up on high-risk areas. Focus is being given to finalising audits on a timely basis with audit clients and to the importance of the implementation of audit recommendations within the required timescales.

### **38. Governance and Audit Committee Statement**

39. Based on the evidence presented to the Governance and Audit Committee during 2022/23, it is the considered view of the Governance and Audit Committee that the Council does have, for the most part, sound internal controls and governance arrangements in place. Strategic risks representing the true challenges facing the Council are captured and reviewed on a regular basis. Examples of where the Committee continues to have concerns, which will be incorporated into the Committee's Work Programme for 2022/23, include:

### **Budget Management**

40. The Committee recognises the sustained financial pressure that the Council is under and notes that whilst the overall financial position was balanced, some particular directorates had significant overspends for which control improvements are needed, and management attention and actions are required in directorates to achieve budget savings proposals put forward. Sound budget management is essential in the context of a challenging economic environment, continued constrained finances and an ever-increasing demand for services.
41. The financial challenge continues to be significant, with a budget gap of £113.4 million reported based on current financial modelling over the next four years. The Committee is keen to observe effective arrangements for budget management and control during 2023/24. The Committee will carefully consider budget management arrangements over the year to come, through observing the use of appropriate management controls and interventions and continuing to reinforce expectations for delivery.

## 42. Internal Control

43. As Assurance on compliance and control is essential. For a number of years there have been continued constraints on resources, together with a growing population and greater demand for public services. As the Council faces significant challenges in how it delivers services, it remains essential that internal controls are not neglected or impaired, and that strong controls operate throughout reformed processes and systems. Additionally, the pandemic has necessitated the adaptation of systems, and in some cases the design of new systems, in order to respond to new priorities. We have been advised of the consultation, advice and guidance provided by the Internal Audit and Investigation Teams to support management to design and uphold robust controls as they have navigated new priorities and responsibilities.
44. The Committee has invited senior officers to attend its meetings this year, to account for their delivery of good governance, risk management and control. In addition, the Committee has continued to receive the details of all Internal Audits completed, and the respective assurance ratings. This year we have observed isolated internal control gaps through reports of insufficient assurance, and one unsatisfactory audit opinion. Whilst the number of unsatisfactory Internal Audit opinions remain low, management must maintain sound systems of internal control and promptly address identified weaknesses.
45. We have maintained close interest on the robustness of controls in relation to the Waste Management function. In recent years, alongside a police referral and investigation, a wide-scale internal investigation into allegations of fraud was completed and disciplinary proceedings have concluded. Through discussions with the Director and the Audit Manager we are advised that there has been steady and sustained progress in recent years in the internal control environment, led by the senior management in place. Our Committee has been advised that there are mechanisms for delivering and acting on improvement actions, and that there is a constructive two-way relationship with Internal Audit, in the planning of, and response to, assurance work. We recognise the progress made for which continued management attention and assurance are required.
46. The Committee has access to all Internal Audit recommendations raised and agreed, and visibility of updated management comments until the point of implementation. Whilst the Committee has an overall assurance of internal control, we continue to require officers to account for services or functions where internal control weaknesses have been identified. We continue to challenge any impairment in stewardship and control of public funds and assets, seeking prompt and proportionate management actions. The Committee has considered and approved the Internal Audit Plan for 2023/24 and will closely monitor its progress and findings over the year ahead.



47. In a position of constrained finances, the Committee will continue its consideration of the framework for financial decisions. The Committee has received regular updates on financial resilience and, in recent years has welcomed the independent assurance of the Council Treasury Management activities, by the Council's Treasury Management advisors, further to the regular assurance provided by Internal Audit.
48. The Governance and Audit Committee will continue to look to gain assurance of sound treasury management practices and strategy. This is vital work, which will both safeguard and deliver best value from the Council's borrowing and investments. The Committee has and will continue to seek assurance that the levels and profiles of investments and borrowing are appropriate and in line with the Treasury Management Practices, Strategy and Reports presented.

#### **49. Schools Governance & Compliance**

50. The Committee has sought regular reports from senior management in the Education and Lifelong Learning directorate seeking ongoing assurance on the arrangements to manage school balances, and to address audit recommendations. Our Committee has raised concerns over delays in implementing school audit recommendations, and the Director of Education and Lifelong Learning has committed to providing a full analysis of outstanding audit recommendations by the end of this academic year.
51. Our Committee has noted positive improvements made, as recognised by Estyn, and we will continue to keep a keen interest in the governance arrangements and assurance we receive in respect of schools. This is with the understanding that the Governance and Audit Committee can request the attendance of those solely responsible for governance at an individual school level, to a Committee meeting, in the event that assurances are not considered as sufficient.
52. The Committee acknowledges that the Council is not able to set rules for schools to adhere to regarding contracting matters, albeit advice can be offered on good practice. This area of interest remains a priority of the Committee and we continue to support the production and use of best practice guidance in schools to strengthen financial stewardship and control.

#### **ii) Governance Framework - Supporting Information**

##### **A. Behaving with integrity, demonstrating strong commitment to ethical values, and respecting the rule of law.**

53. All Members and Officers in the Council are required to comply fully with Codes of Conduct as set out in the Constitution, which sets out the particular roles and

responsibilities of Officers and Members and provides clarity on the interfaces between these roles. These include:

- Functions and subsections delegated to Officers
  - Members' Code of Conduct (Including Social Media Principles)
  - Employees' Code of Conduct
  - Protocol on Member / Officer Relations
  - Cardiff Undertaking – signed by all Members upon election and underlines their duties to the City and its citizens.
54. The Director of Governance and Legal Services is the Monitoring Officer and has the specific duty to ensure that the Council, its Officers, and its Elected Councillors, maintain the highest standards of conduct in all they do based on Section 5 of the Local Government and Housing Act 1989, as amended by Schedule 5 paragraph 24 of the Local Government Act 2000. During 2023/24 the Director of Governance and Legal Services tendered their resignation and left the Council on 27 October 2023. As agreed at Council on 26 October 2023, interim arrangements were put in place for both the Council and the Cardiff Capital City Region in advance of anticipated conclusion of permanent appointments being made in the forthcoming months.
55. The Standards and Ethics Committee has a responsibility to monitor and scrutinise the ethical standards of the Authority, its Members, employees and any associated providers of the Authority's services, and to report to the Council on any matters of concern. The Committee is chaired by an independent person and its role includes determining the outcome of complaints against Councillors and Co-opted Members and monitoring the Council's whistleblowing procedures.
56. In 2022/23, the Monitoring Officer was notified of a total of seven complaints relating to Member conduct. The Public Services Ombudsman has considered six of the complaints and determined that there was no evidence of a breach of conduct and declined to investigate. The remaining complaint was informally resolved.
57. The Chair of the Standards and Ethics Committee the outgoing Chair presented the Committee's Annual Report 2022/23 on 30 October 2023 and outlined the work of the Committee. The report identified actions in respect to considering the Members Exit Survey of 2022, review of the Cardiff Undertaking, consideration of the use of Council IT for Political group meetings, continuing to observe Council and Committee proceedings and overseeing training on the Members' Code of Conduct following the local government elections in May 2022. In addition, the Committee has reviewed Personal interests for both Members and Senior Officers and issued periodic updates of the Committee's work to Council Members. The Annual report also noted that the planned review of the Whistleblowing Policy for 2022/23 was delayed and was to be rescheduled for the year 2023/24. The Committee believes that presentation of its Annual Report to Council serves to promote Members' understanding of the

important role of the Committee and its work; and that further Member briefings will continue to be issued as and when required.

58. Members and Co-opted Members are required to register their personal interests in any business of the authority, and to comply with the rules on personal interests set out in the Members Code of Conduct. Significant work has been undertaken this year to ensure that Members complete all relevant forms. All personal interests disclosed by Members are published on the Council's website within the Member's profile information. The Council's Policy on Officers' Personal Interests & Secondary Employment requires all staff to disclose any personal interest which actually or potentially conflicts with their duties to the Council and all secondary employment. The policy sets out how all Council employees are obliged, under the Employees' Code of Conduct, to ensure that their private interests do not conflict with their public duties, and to comply with the Council's rules on the registration and declaration of financial and non-financial interests.
59. The Council's Corporate Values focus on fairness, openness and working together. The Council supports a culture of behaviour based on these values which guide how the long-term vision of the Council is put into effect, as well as how Members and Officers deliver their day-to-day roles. Corporate and directorate planning, and personal performance and development arrangements are aligned to delivering corporate values and priorities.
60. The Workforce Strategy and Employee Charter continues to ensure that there is alignment between the Council's vision and values and the Corporate Plan:
  - The Employee Charter sets out the expectations of all staff (employees, managers and senior managers) and has formed part of the objective setting process for personal reviews
  - The Workforce Strategy seeks to deliver outcomes for and with employees, within a culture that supports a flexible, skilled, engaged and diverse workforce.
61. The Council takes fraud, corruption and maladministration very seriously supported by the following strategy and policies to prevent and manage such occurrences.
  - Counter-Fraud and Corruption Strategy
  - Financial Procedure Rules
  - Contract Standing Order and Procurement Rules
  - Whistleblowing Policy
  - Fraud, Bribery and Corruption Policy
  - Anti-Money Laundering Policy
  - ICT Security Policy
  - Data Protection Policy & Procedure
  - HR policies regarding investigation and discipline of staff

62. The Counter-Fraud and Corruption Strategy has been in place since July 2019 with over 6800 staff and school governors having undertaken the course or attended face-to-face training / workshops. The Counter - Fraud and Corruption Strategy is scheduled to be updated in 2023/24 with refreshed training material to support its launch. The Council continues to be supported by a range of policies, procedures and regulations which are reviewed for appropriateness, including those relating to Financial Control, Data Protection, Health & Safety, Equalities and IT Security.
63. The Council has a Whistleblowing Policy in place through which staff and contractors are encouraged to speak out on misconduct or illegal behaviour within the organisation, which affects the public or other people (making a disclosure in the public interest). In 2022/23 a total of seven whistleblowing cases have been reported to the Monitoring Officer.
64. The Corporate Director Resources has both overall responsibility for the financial administration (S151 Officer) and the information governance arrangements of the Council (SIRO). The Council's financial management arrangements conform to the governance requirements of the Role of the Chief Financial Officer in Local Government) which is set out in the CIPFA Financial Management Code (2020).
65. The Council continues to consider its Financial management against the CIPFA Financial Management (FM) Code. The focus of the code is to improve the financial resilience of organisations by embedding enhanced standards of financial management. Inevitably, the impact of wider geopolitical and economic factors continued to test that financial resilience in 2022/23. The CIPFA Financial Management (FM) Code is intended to support good practice in financial management and assist Local Authorities in demonstrating their financial sustainability. The Code translates principles of good financial management into a series of standards against which Local Authorities should measure themselves.
66. Building on the Assessment undertaken in 2021/22, a further self-assessment against the FM code was undertaken in 2022/23 by senior Accountancy officers and the results presented to the Section 151 Officer to identify opportunities for improvement. Considering the significant financial uncertainty facing the Council, the Section 151 Officer agreed that the self-assessment continued to focus on the three previously identified areas for the forthcoming period months. Firstly, recognising the increasing volatility and uncertainty of financial challenges to further build on the work undertaken in increasing the range of suitable sensitivity analysis when determining the Medium-Term Financial Plan. Secondly, the financial resilience of the Council will be enhanced by building on the work undertaken to ensure strong links between Business cases and plans to spend. The third recommendation was to maintain focus on service area budget spend with the need to find increased level of budget savings to be delivered but the heightened need to identify any financial issues quickly to have time to put remedial action in place. In addition, the work undertaken in 2022/23 on income culminated in the Income Generation Framework being produced as part of the Council's 2024/25 Budget Strategy.

67. The requirements of the FM Code and the need for evidence has been a major consideration in the development of the Council's key financial strategies such as the Medium-Term Financial Plan, Capital Strategy and the Treasury Management Strategy.

**B. Ensuring openness and comprehensive stakeholder engagement.**

68. Through its Corporate Values, the Council outlines a commitment to being "open and honest about the difficult choices we face and allowing people to have their say on what's important to them and their communities." Consultation, engagement and joint working with citizens are central to delivering this value and are outlined as follows.

69. Meetings have remained open to the public to attend except where confidential or exempt information is being discussed, as defined by the law. Full Council meetings continued to include a facility for public questions, and the Council's Scrutiny Committees have invited stakeholder contributions to their scrutiny programme, both through research and consultation exercises and through direct access to Committees.

70. In 2020 – 21 as a result of the coronavirus pandemic, temporary legislation required all Council meetings to be made publicly available which was achieved by either by live streaming meetings or recording them to be subsequently uploaded to the web due to the public being unable to attend meetings in person . The implementation of the Local Government and Election (Wales) Act 2021 superseded this legislation and required principal councils to develop and implement a Multi-Location Meetings policy. The Council approved its Multi-location meetings policy in March 2022 for implementation following the Local Government Elections on 5 May 2022.

71. The policy exceeded the legislative requirement to broadcast Council meetings and identified additional committee meetings of public interest or those with a governance role to be webcast. These meetings included Council, Cabinet, Planning Committee, Governance and Audit Committee, Standards and Ethics Committee and Scrutiny Committees with other meetings being recorded and kept for reference.

72. The following table highlights the activity of webcasting through the last five years. Although the number of meetings webcast has reduced, the average number of live views for a meeting has **doubled** from 25 in 2021-22 to 55 in 2022-23. There has been a **70% increase in** archive views for a meeting from 88 in 2021-22 to 151 in 2022-23. In total, all views for a meeting have **increased** by almost 82% from 113 in 2021-22 to 206 in 2022-23

Webcasting Data				
Year	2019-20	2020-21	2021-22	2022-23
Number of Meetings webcast	54	105	155	88
Number of Committees (Types) webcast	10	21	19	14
Total Hours Webcast	126:50:24	202:36:54	269:39:22	177:55:44
Live views	1960	4594	3965	4871
Archive Views	6909	10963	13644	13287
Total Views	8869	15557	17609	18158

73. There has been open debate and challenge on performance and risk management with quarterly reporting and review in Senior Management Team (SMT) and further challenge and oversight in Cabinet, Scrutiny and Governance & Audit Committee meetings. An Assurance role continues within the SMT environment where the Chief Executive, and Directors discuss aspects of the assurance, for example safeguarding, procurement compliance, performance management, outcomes and progress on audit recommendations made by internal and external auditors, bodies and regulators. This continues to highlight the connections between these assurance pieces and created a more joined up version of the assurance picture. The meetings between the Chief Executive, Directors and Cabinet Members to agree actions arising from an open debate of performance and service delivery challenges have continued for 2022/23.
74. The public and other stakeholders are given the opportunity to tell the Council what they think about the services provided through the Council's Comments, Complaints and Compliments Policy. It reflects guidance given in the Welsh Government Model Policy and Guidance Paper for Handling Complaints, as well as guidance received from the Public Service Ombudsman for Wales and places a greater emphasis on a prompt resolution of complaints. Cabinet is informed annually of the number of complaints received.
75. Citizens, communities and partners continue to be engaged through a programme of citizen engagement, budget consultation, Ask Cardiff surveys that seek opinions of a range of Quality of Life and Quality of Services statements. The output of these is used to inform proposals and decisions of priorities and planning for the provision of services. The participation levels for these engagement sessions continue to leave room for improvement particularly in respect to building up participation numbers.
76. Regular meetings are held with institutional stakeholders to whom the Council is accountable, which include the Welsh Government and the Council's External Auditors (Audit Wales). Efforts have also been made to foster open

and effective relationships between the County Council and the six Community Councils in Cardiff through a Community Councils Charter (“the Charter”). It reflects the model Charter issued by the Welsh Government in the Local Government (Wales) Measure 2011 and is based on equality of partnership between the two tiers of local government.

77. The Cardiff Public Services Board (PSB) represents a statutory partnership of public and voluntary sector organisations, chaired by the Leader of the Council to deliver the city’s Wellbeing Plan. The Wellbeing Plan, which responds to the evidence from the Wellbeing Assessment, focusses on the areas of public service delivery which fundamentally require partnership working between public and community services, and the citizens of Cardiff. The Wellbeing Assessment agreed by the PSB in March 2022 and the draft Wellbeing Plan was considered in October 2022 prior to public consultation. Cardiff PSB is supported by partnership governance and delivery arrangements, reporting by exception into the PSB on a quarterly basis. Over the course of the pandemic, the Cardiff PSB has met on a more regular basis to lead a co-ordinated strategic response to critical issues across the city’s public services. The Cardiff Local Well-Being plan was considered by the Cardiff PSB in April 2023
78. The Cardiff Public Service Board delivered a review of its Partnership governance in February 2023 and concluded that there was a need to build on the partnership approach that arose during the pandemic characterised by day-to-day strategic and operational working across organisational boundaries, of sharing assets in support of shared goals and of moving quickly in a rapidly changing environment, enabled by technology and supported by data.

C. **Defining outcomes in terms of sustainable economic, social, and environmental benefits.**

79. Following the local government elections on 5 May 2022, a new Council administration was formed. To make clear its ambitions for the city, the administration set out a new policy programme and associated delivery commitments for the coming municipal term, entitled ‘Stronger, Fairer, Greener.’ This was agreed by Cabinet at its meeting of 14 July 2022, and set out the Council’s policy agenda and programme for delivery for the next five years, based on the following commitments to make Cardiff:
  - **A stronger city**, with an economy creating and sustaining well-paid jobs, with an education system that helps our young people reach their potential, with good, affordable housing in safe, confident and empowered communities, all supported by well-resourced, efficient public services.
  - **A fairer city**, where the opportunities of living in Cardiff can be enjoyed by everyone, whatever their background, where those suffering the effects of poverty are protected and supported, where a fair day’s work receives a fair day’s pay, and where every citizen is valued and feels valued.
  - **A greener city** which, through our One Planet programme, takes a lead on responding to the climate emergency, which celebrates and nurtures

biodiversity, with high-quality open spaces within easy reach for rest and play that are connected by convenient, accessible, safe sustainable transport options.

80. Where 'Stronger, Fairer, Greener' provided a clear articulation of the administration's policy priorities, the Council's policy framework translated these into organisational objectives with associated delivery milestones, key performance indicators and the necessary resources to ensure progress.
81. The Corporate Plan, therefore, plays a key role in translating the administration's policy ambitions into clear organisational objectives. In this way, the Corporate Plan sets out what the Council wants to achieve, and how it will organise itself to achieve it. In accordance with the requirements of the Well-being of Future Generations (Wales) Act 2015, the Corporate Plan is framed by Well-being Objectives, Steps and performance measures. The Corporate Plan is set at a strategic level and is supported by directorate delivery plans, which set out in greater detail how Corporate Plan objectives will be delivered, as well as how directorate business will be taken forward.
82. The Council has responded to performance requirements arising from the Local Government and Elections Act (Wales) 2022 which are set out in the Annual Governance Statement of 2021/22.
83. The development of the Annual Well-being Report, in effect the Council's self-assessment of performance, involves the political and managerial leadership of the Council, with enhanced roles for both Scrutiny and the Governance & Audit Committee. This will include:
  - Directorate self-evaluation of service performance, governance & financial challenges and priorities;
  - Performance and budget assurance sessions with each Director that are convened by the Chief Executive and Section 151 Officer to consider findings of directorate self-assessment;
  - Progress and performance session with Cabinet and the Council's Senior Management Team;
  - The Performance Panel, convened by the Chair of the PRAP Scrutiny Committee, and involving the Chairs of each of the Council's Scrutiny Committees
  - Consideration by both the PRAP Scrutiny Committee and the Governance & Audit Committee
  - Consideration of the End-of-Year Assessment (the Annual Well-being Report) by Council.
84. A Mid-Year Self-Assessment was considered by Cabinet on 19 January 2023, following engagement with the Policy Review and Performance (PRAP) Scrutiny Committee. The report set out challenges in six areas; The pressures on the organisation in respect to workforce, financial resilience, Housing, Children's Services, within Health and Social Care (thus requiring a heightened



partnership approach) and the continued need to respond to the pressures of the Cost of Living.

85. Thematic Challenge Sessions are convened by Well-being Objective each January/February. The challenge sessions are chaired by the Leader and Cabinet Member for Finance, Modernisation and Performance and involve the lead Cabinet portfolio holders, Chief Executive and relevant Directors. The challenge sessions consider progress and challenges in relation to each of the Well-being Objectives within the Corporate Plan, and provide an opportunity to consider priorities, steps, Key Performance Indicators and targets for the year ahead.
86. There is Engagement with the Performance Panel each January/February. The Performance Panel allows the Chairperson of each Scrutiny Committee, to:
  - i. Consider the Mid-Year Assessment and make recommendations for improvement as well as strategic policy suggestions for consideration as part of Corporate Plan development
  - ii. Corporate Plan development; with a focus on the priorities, steps, Key Performance Indicators and targets proposed for inclusion within the revised Corporate Plan.
87. The Corporate Plan is part of the Council's Policy Framework and this, as set out in the Constitution of the Council, ensures that the Corporate Plan is formally subject to consideration by all elected members. Engagement occurred throughout February 2023 with all Scrutiny Committees including PRAP Scrutiny Committee as part of pre-decision scrutiny of the Corporate Plan. Formal consideration by Cabinet and Council concluded on 9 March 2023.
88. The Corporate Plan is developed alongside the Council's Budget, thereby ensuring that the Council's resources are aligned behind the delivery of its policy priorities. The Corporate Plan and Budget are approved alongside one another by Council in February / March of each financial year. Both the Council Budget and Corporate Plan were approved on 9 March 2023.
89. The financial uncertainty over the last couple of years has led to delays in Budget Settlement from Welsh Government and this continued for both the budget setting process of 2023/24 and the forthcoming budget of 2024/25. The Council's 2023/24 budget proposals ran from 23 December 2022 to 29 January 2023 with the budget consultation for 2024/25 budget proposals was launched on 8 January 2024 with an end date of 4 February 2024. As outlined under principle B of this AGS, ensuring openness and comprehensive engagement, several mechanisms were used to ensure the consultation was as accessible as possible, but improvements are required in the number of engagements achieved. The consultation enabled members of the public to communicate their views on the budget proposals. It informed the final decisions on service

changes, which focussed on delivering valued public services in the face of ongoing austerity.

90. Building on the approach to the Council's Budget Strategy over the last few years is key to planning for future years. The Council Budget report of 9 March 2023 identified for 2023/24 a budget gap of £113.4 million gap for the period 2024/25 to 2027/28. The outlook over the short term looking particularly challenging but with signs that the medium / long term will become significantly harder. These pressures being due to the challenge of managing the increase in demand for services, rising cost pressures and recovering lost income levels in other areas such as cultural venues and school catering. Looking further forward, Cabinet considered both a Budget Strategy refresh on 13 July 2023 and 8 January 2024 both of which outlined the unabated financial pressure on the Medium Term.
91. Delivering the 'Stronger, Fairer, Greener' policy agenda will also require coordinated action by the Council and its partners. The Cardiff Public Services Board (PSB), chaired by the Leader of the Council, brings together the city's public and third sector leaders, and builds on the long-established platform of partnership working in the city. The Well-being of Future Generations Act has placed in statute the role of PSBs and requires PSBs to publish an assessment of local wellbeing, a local wellbeing plan and annual progress reports.

**D. Determining the interventions necessary to optimise the achievement of the intended outcomes.**

92. As in previous years, it continues to be the case that all Cabinet and Council decisions taken by Members are supported by authored reports from Officers on the legal, HR, property and financial implications arising from the decision. These reports are also required to outline the economic, social and environmental outcomes, member consultations, the key risks and alternative courses of action which are available.
93. To meet requirements of the Well-being of Future Generations (Wales) Act 2015, the Council has published well-being objectives and a well-being statement as part of the development of the Corporate Plan. As referenced in the March 2022 Council the Corporate Plan does ensure ongoing consideration of the sustainable development principle with a focus placed on considering the 5 ways of working at the earliest stage of policy development. Policy development, across the organisation, is encouraged to consider:
  - **Long term:** Defined as the trends that affect Cardiff both today and in the future.
  - **Prevention:** Intervening earlier to prevent problems affecting citizens from occurring or worsening.
  - **Involvement:** Engaging with citizens, particularly the most vulnerable in society.

- **Integration:** Working across boundaries to deliver the administration's policy agenda for the city.
  - **Collaboration:** Working with others to have a greater impact.
94. The Council uses several sources of information to self-assess progress against Well-Being Objectives, including:
- **Progress against the Council's Key Performance Measures** – Several performance measures are identified within the Council's Corporate Plan which help show the progress made in delivering the Well-Being Objectives. Where applicable, targets are set against these performance measures to demonstrate the desired level of achievement. Performance measures are assigned a RAG status: GREEN where the measure is on or above target, AMBER where the result is within 10% of the target and RED where the result is greater than 10% from the target.
  - **Progress against the Steps in each Well-being Objective** – The Council included a number of Steps in the Corporate Plan to help achieve the Well-Being Objectives. Monitoring the progress of these Steps provides an understanding of what has been achieved and where further work is required.
  - **Inspection Reports** – The Council is subject to inspections from regulatory bodies including the Wales Audit Office, Estyn (Education) and the Care and Social Services Inspectorate Wales (CSSIW). Their findings help the Council to assess areas of strong performance, as well as identifying areas that require improvement.
  - **Surveys and Citizen Feedback** – The annual Ask Cardiff survey, as well as more specific consultation and engagement work, provide residents an opportunity to share their views on a wide range of the Council's services.
  - **Finance Monitoring** – The Council's Outturn Report and Budget Monitoring
  - **Feedback from Scrutiny Committee and the Governance and Audit Committee** – The Council responds to the issues raised and recommendations made by Committees, which help inform performance improvement.
  - **Risk** – The Council's Corporate and Directorate Risks are considered as part of a rounded view of performance..
95. By using this information, the Council monitors progress but also identify areas of improvement, celebrate success and identify areas where performance may not have been as good, and therefore the areas that may require further attention.
96. The Council also has in place a robust performance and accountability regime which involves the wider political governance of the Council. In developing the self-assessment of performance, the following steps have been undertaken to ensure a full and balanced assessment:

- Directorate Analysis of Performance
  - Assurance Sessions convened by the Chief Executive with each Director
  - Assurance Sessions, convened by Cabinet, with the Chief Executive and the Council's Senior Management Team
  - Performance Panel Review, convened by the Chair of the Policy Review and Performance Committee, and involving the Chair of each of the Council's Scrutiny Committees.
  - Consideration by the Policy Review and Performance Scrutiny Committee
97. Communication to staff remained a key focus and to ensure staff were consulted, and involved in decision making, various channels of communication were used including the Chief Executive's Update, Core Brief, Staff Information messages, the Staff App, and DigiGov (the Council's HR system).
98. The engagement of citizens has continued to be an important means of identifying and designing services to meet the needs and expectations of service users and citizens in Cardiff in the context of budgetary constraints. Improvements have been identified and put in place to ensure that impact assessments are put in place to ensure that all groups are engaged when considering service change or budget proposals. To support project-based decision making, the Council continues to have in place a Business Case template using the Office of Government Commerce (OGC) "Five Case Model" but with a focus in ensuring that the process does not become overly bureaucratic and remains a value added activity in delivering assurance on risks and opportunities. The Capital Programme development requires robust full Business Case to be allowed for consideration of the following year budget determination.
99. The Council's Budget Strategy is based on an incremental budgeting approach where budgets are informed to a greater extent by corporate priorities and the required future shape of the organisation. The themes for savings in the Budget Strategy for 2023/24 and 2024/25 were categorised as Efficiencies, Service Change and Income Generation and were a reflection of the challenging financial climate with inflationary costs and demand pressures exceeding funding increase changes. The 2023/24 budget monitoring reports have detailed a reduction in performance complied to that of 2022/23 and this reflects the increasing degree of difficulty in savings proposals being made.
100. During 2022/23, there was consideration of the need to review governance and reporting in Council subsidiaries. During 2023/24 this work has progressed and looks to cover three broad areas in respect to Subsidiaries through a high level review of governance approach, to undertake a high level comparison of identified best practice for Subsidiaries and the Shareholder and to set out some initial recommendations that the authority could consider for existing and future subsidiaries where there are identified gaps in governance and reporting.

**E. Developing the entity's capacity, including the capability of its leadership and the individuals within it.**

101. Decision making responsibilities and authority are clearly set out in the Council's Constitution. It documents the roles and relationships for decision making, between the Full Council, the Cabinet, Scrutiny and other Non-Executive Committees. It also details decisions delegated to senior officers through the different management tiers.
102. The Cabinet is the part of the Council which is responsible for most major decisions. The Cabinet is made up of the Leader elected by the Council, and up to nine other portfolio Cabinet members whom he/she nominates for approval by the Council. For 2021/22, the legislation now provides for Cabinet Members to job share and that was been considered for 2022/23 with two portfolios being shared. The Cabinet must make decisions which are in line with the Council's overall policies and budget. If it wishes to make a decision which is outside the budget or policy framework, this must be referred to the Council to decide.
103. The senior management structure of the Council for 2022/23 did not change. The statutory responsibility for Social Services is delegated to the Corporate Director of People and Communities. The Statutory roles of the S151 Officer (Finance) and the Monitoring Officer continue to be discharged by the Corporate Director (Resources) and the Director of Governance and Legal Services, respectively. During 2023/24, the Chief Executive was absent for the period of June 2023 to October 2023 and the delegations of this role were split and provided to the Corporate Director of People and Communities and the Corporate Director of Resources.
104. The Council aims to ensure that Members and Officers have the skills, knowledge and capacity to discharge their responsibilities effectively and recognises the importance of well trained, competent people. For the intake of May 2022, all 79 Members were invited to attend an induction programme to introduce them to or refresh them on the Council and its values, objectives, policies and procedures. The Programme was a mix of online and face to face modules which was evaluated by those who attended to provide insight into future needs or preferred delivery of training. The attendance figures were significantly higher for new members with the overall participation rate being 97.47% for the five mandatory training topics.
105. All new officers undertake the appropriate level of induction which includes a suite of mandatory e-learning training modules. Each mandatory training module has its own target date for full compliance. The mandatory training modules for all staff cover Corporate Safeguarding, Cybersecurity, Data Protection, Fraud Awareness Introduction to Welsh Language Violence

Against Women and Domestic Violence and Children's rights. The performance against each modules reported and linked with individual personal reviews. Work was undertaken during 2022/23 to refresh some of these modules with new versions of Cyber Security, Fraud and Data protection being issued in 2023/24. There are also training modules designated as mandatory for those staff who perform particular roles, and these modules include VAT awareness, Payment Card Industry and Buying Responsibly.

106. The In-house Cardiff Manager Programme represents a commitment to increasing the learning and development of staff with line management responsibilities. The programme continues to be offered more widely across the officer body without the requirement to sit a formal ILM level 3 qualification.
107. Performance is primarily evaluated through the Council's Personal Review process, which provides a framework for employees and managers to discuss work performance and behaviour as well as to identify learning and development needs. It enables employees to be clear about their roles, responsibilities and the behaviours expected of them whilst giving a clear understanding of how their job and efforts contribute to the Council's objectives. Member Personal Reviews are also in place to help them update their knowledge and learn new skills, where required, to be more effective in supporting their communities. The Cardiff Council Academy delivers a comprehensive suite of learning and development programmes and courses which can be accessed and delivered remotely.
108. The Council's Workforce Strategy has employee health and wellbeing as a priority. The Council continues to support the 'Time to Change' Pledge, has been recognised as a Level 2 Disability Confident Employer and the accreditation has been extended to October 2026, and continued to adhere to the Dying to Work Charter and the Corporate Health Standard Silver Award.
109. The Council approved and published the 2022/23 Annual Wellbeing Report in September 2023, in accordance with the requirements of the Wellbeing of Future Generations (Wales) Act. This provides a retrospective summary evaluation of performance for 2022/23 and building on the midterm assessment identified areas of focus moving forward as being Managing sustained increase in the complexity and scale of demand across Council services: Responding to new risks and issues: Workforce pressures now impacting on all council services: Ensuring continued financial resilience:
110. The Council has determined that two independent non-executive directors with proven skills in governance and transport services should be co-opted to the Boad of Cardiff City Transport Services Ltd. (Cardiff Bus), one of the Council's wholly owned subsidiary companies. One appointment has been made following the Council meeting on 30 March 2023, with completion of the recruitment process to take place and be considered by Council in 2024

**F. Managing risks and performance through robust internal control and strong public financial management.**

111. Risk management is an integral part of strategic decision making, forming a key element of business planning, budget proposals, budget strategy, and programme and project considerations. A Corporate Risk Register (CRR) is maintained and reviewed by SMT each quarter to ensure it includes key risks to the corporate vision, objectives and priorities. A Corporate Risk Map has also been used throughout 2022/23 to provide a transparent representation of the status of corporate risks and to support a proportionate management response.
112. The Risk Management Strategy and Policy continued to be supported by a nominated Member Risk Champion, Senior Officer Risk Champion and a network of Directorate Risk Champions. This process is designed to ensure clear ownership of risks which are identified, reviewed and escalated systematically each financial quarter. There has been an increasing trend to highlight target dates for individual risk actions for each area of the Corporate Risk Register and this will look to be extended across all Corporate risks in the next year.
113. The Council's five standing Scrutiny Committees are designed to support the Cabinet in providing accessible, efficient and effective services for citizens. For the year 2022/23, the Scrutiny Committees were able to meet throughout the year. There were 40 Scrutiny Committee meetings held during the municipal year 2022/23.
114. Scrutiny Committees undertake pre-decision scrutiny, policy monitoring and review and launch in-depth inquiries to help the Cabinet develop and review policies and services. Most recommendations raised to Cabinet following Scrutiny Inquiries are fully accepted. A number of the Council's collaborative activities are governed by Joint Committees which can be identified on the Council's website.
115. The Council has robust arrangements for internal control which are set out within the three statements contained within this report from the Audit manager, Governance and Audit Committee and Senior Management, respectively.
116. There continued to be formal engagement on Health and Safety between appointed Elected Members, Union Representatives and relevant Council Officers. The Health and Safety Forum met four times during the year with the focus being on the consideration of accident and violence at work statistics and providing regular updates of the management of Health and Safety reporting and Statutory Obligations Contract management.

**G. Implementing good practices in transparency, reporting, and audit to deliver effective accountability.**

117. The Council continues to aim to ensure that all reports for the public and other stakeholders to be written in a fair, balanced and understandable way. It remains the case that there is a need to achieve a balance between providing

full and complete information to demonstrate clear transparency without being onerous or overly complex.

118. The Council also aims for information to be easy for the Council and the public to find and use. The Council has where practicable looked to publish information in advance rather than await Freedom of information Requests. The Council takes careful consideration of the model publication scheme set out by the information Commissioner which sets out the classes of information that should be routinely available. The Council acknowledges that it has not fully conformed with the model publication scheme due to practical reasons such as capacity and ease of accessing information. However, the Information Commissioner's has recently revised its model publication scheme and the Council is currently reviewing its position against the new expectations and will seek to improve the level of its adherence to the expectations set out in the document.
119. The AGS is an assessment of the governance of the Council applied to the 'Delivering Good Governance in Local Government' CIPFA / SOLACE framework, as outlined in the Assessment Process and Summary. (SMAS). SMT hold an action plan of significant governance issues, representing an open disclosure of the most prominent issues of governance which require attention following the SMAS review. The AGS Action Plan for 2022 and 2022/23 are both included in the following section.
120. In May 2021, the Council met to establish Committees: their size, terms of reference and allocation of seats. Most meetings have sought to encompass hybrid meeting technology which commenced in June 2022. The Council's Constitution is reviewed at least twice a year and sets out the terms of reference for each of its Committees and the decisions that can be taken by each of those Committees. Council has appointed a number of Committees to discharge regulatory and scrutiny services and they deliver annual reports on their performance and findings.
121. Prior to services being delivered through third parties or via joint working arrangements, the Legal Services Team assist directorates to ensure responsibilities and accountabilities for governance and risk management are adequately documented. The risk management strategy and policy require clear risk management arrangements in whichever model of service delivery is used.
122. Peer challenges, reviews, and inspections from regulatory bodies are welcomed by Cardiff Council to provide assurance over service delivery or identify opportunities for improvement.



## **2022/23 AGS Action Plan – Significant Governance Issues**

123. An Action Plan of Significant Governance Issues is owned by the SMT and is formally reviewed and updated on a bi-annual basis. The review is supplemented by Challenge sessions for each Directorate chaired by the Chief Executive and accompanied by the Corporate Director of Resources. The three areas considered for 2022/23 were carried forward from 2021/22 and were considered to be the main areas of focus or governance improvement. The Actions and Progress to date are set out below.

### **ACTION : Extend and deepen the areas of SMT investigation in respect to compliance, risk and outcomes. – CLOSED**

The challenge of delivering services with increased demand and less available financial resources has highlighted the importance of compliance areas being reported and considered at Senior management level. This action was proposed to be closed as it now forms part of the working model going forward. Regular reports on individual directorates have been considered and discussed at SMT level on areas such as Service delivery issues, Safeguarding, Risk, Procurement, Sickness Absence, Performance Reviews and Internal Audit recommendations have been received during the year. Data has accompanied reports that enable SMT to identify areas of improvement and to ensure that progress where needed is achieved.

### **ACTION: Extend the assurance on the quality of performance reviews through evidence gathering at Directorate level. – Taking forward to 2023/24**

SMT have regularly received reports on compliance on Performance reviews. The Directorate delivery plans continue to be the source of personal and team objectives although it continues to be acknowledged that this is not the case at all levels due to the scope and scale of some directorates. The quality of performance reviews remains an area where further improvements are required to ensure that this is fully embedded throughout individual directorates.

### **ACTION - Embed into the self- assessment on Assurance the Five ways of Working in respect to the Future Generations Act. – Taking forward to 2023/24**

The Self- Assessment on assurance has been amended to include a specific set of questions which covered the Five ways of Working in respect to the Future Generations Act. The Directorates have assessed themselves against these objectives for the period of 2022/23 but there was a need to keep this action for 2023/24 to ensure sustainable improvement has been made across all directorates.

**Certification by the Leader of the Council and the Chief Executive**

**Councillor Huw Thomas, Leader of Cardiff Council**

**Date:**

**Paul Orders, Chief Executive**

**Date:**

Governance and Audit Committee Action Plan and Recommendations  
(Updated following meeting held on 28 November 2023)

1. Action Plan

Minute No. /Agenda No.	Actions	Timeline	Action Owner
	<b>Finance (Budget)</b>		
	No Outstanding Actions		
	<b>Governance &amp; Risk Management</b>		
	No Outstanding Actions		
	<b>Audit Wales (AW)</b>		
	No Outstanding Actions		
	<b>Internal Audit</b>		
	No Outstanding Actions		
	<b>Treasury Management</b>		
24.10.23	A briefing would be provided to the Committee in respect of borrowing and associated accounting principles, to include the minimum revenue provision.	09.01.24 Completed	IA/AH
	<b>Operational Items</b>		
02.04.19	Once disciplinary procedures have concluded within the Waste Management Service, Audit Committee to be informed of the terms of reference and approach for delivering the associated Post Investigation Review.  (Interim confidential assurance briefing paper circulated 3.06.2021)	23.01.24	CL / CP
	<b>AW Tracker/Other Studies</b>		
	No Outstanding Actions		
	<b>Performance</b>		
	No Outstanding Actions		
	<b>Work Programme</b>		
24.10.23	It was agreed that the next risk management item would provide details on the Council's assessment and mitigation of RAAC risks.	28.11.23 Completed	IA
	<b>Outstanding Actions</b>		
	No Outstanding Actions		
	<b>Correspondence</b>		
	No Outstanding Actions		
	<b>Scrutiny Engagement / Letters</b>		
	No Outstanding Actions		

2. Recommendations

Committee Meeting Date	Agenda Item	Recommendation	Date Raised	Management Response	Target Action Date	Status
		No Outstanding Actions				

## Correspondence

The Governance and Audit Committee and each of the Council's Scrutiny Committees have established an arrangement to share and inform each other of their work programmes, enquiries and outcomes.

As part of this process, the Chair of the Governance and Audit Committee and the Audit Manager have been copied into Scrutiny Committee letters over the reporting period. Where responses have been received at the time of reporting, these are also included for information.

Each of the letters have been reviewed by the Audit Manager who has provided relevant comments to the Committee Chairperson.

The information contained within the letters published is useful for Governance and Audit Committee Member awareness of the activities and lines of enquiry of the Council's Scrutiny Committees.

**In considering the terms of reference of the Governance and Audit Committee, and the correspondence received, it is not considered that any updates to the Committee work programme are required.**

For the information of the wider Committee, the published letters since the last Committee meeting were as follows.

For wider information the published Scrutiny Committee work programmes are also linked within this document.

**Chris Pyke**

**Audit Manager  
12 January 2024**

### Children and Young People Scrutiny Committee

Committee Date	Agenda/ Minute No	Item Background Papers	Correspondence Following Committee Meeting
Tuesday 14 <sup>th</sup> November 2023	Minute No. 31	<a href="#">Achieving a Sustainable Youth Work Offer for Cardiff</a>	<a href="#">Link to Correspondence</a> (pages 3-7)

### Community and Adult Services Scrutiny Committee

Committee Date	Agenda/ Minute No.	Item Background Papers	Correspondence Following Committee Meeting
Monday 20 <sup>th</sup> November 2023	Minute No. 20	<a href="#">Homeless Crisis Briefing</a>	<a href="#">Link to Correspondence</a> (pages 3-9)
Monday 20 <sup>th</sup> November 2023	Minute No. 21	<a href="#">Quarter 2 Performance</a>	<a href="#">Link to Correspondence</a> (pages 11-13)
Monday 11 <sup>th</sup> December 2023	Minute No. 28	<a href="#">Care Home Market Review</a>	<a href="#">Link to Correspondence</a> (pages 3-5)
Monday 11 <sup>th</sup> December 2023	Minute No. 29	<a href="#">Housing Emergency Cabinet Report</a> (non-confidential)	<a href="#">Link to Correspondence</a> (pages 7-8)

## Economy and Culture Scrutiny Committee

Committee Date	Agenda/ Minute No	Item Background Papers	Correspondence Following Committee Meeting
Tuesday 21 <sup>st</sup> November 2023	Agenda Item 7	<a href="#">Indoor Arena Funding Strategy</a>  <a href="#">Response to Arena Funding Strategy</a>	<a href="#">Link to Correspondence</a> (pages 11-15) (pages 17-18)
Tuesday 21 <sup>st</sup> November 2023	Agenda Items 4, 5, 6	<a href="#">City Centre Management</a> <a href="#">City Centre Recovery</a> <a href="#">City Deal/Western Gateway Update</a>	<a href="#">Link to Correspondence</a> (pages 3-9)
Tuesday 12 <sup>th</sup> December 2023	Minute No. 58	<a href="#">Tree Planting &amp; Coed Caerdydd</a>	<a href="#">Link to Correspondence</a> (pages 3-5)
Tuesday 12 <sup>th</sup> December 2023	Minute No. 59	<a href="#">Shared Regulatory Services</a>	<a href="#">Link to Correspondence</a> (pages 7-9)

## Environmental Scrutiny Committee

Committee Date	Agenda/ Minute No	Item Background Papers	Correspondence Following Committee Meeting
Thursday 7 <sup>th</sup> December 2023	Minute No. 32	<a href="#">Local Air Quality Monitoring report for the year 2022</a>	<a href="#">Link to Correspondence</a> (pages 3-7)

## Governance & Audit Committee

Committee Date	Agenda/ Minute No	Item Background Papers	Correspondence Following Committee Meeting

## Policy Review and Performance Scrutiny Committee

Committee Date	Agenda/ Minute No	Item Background Papers	Correspondence Following Committee Meeting
Wednesday 22 <sup>nd</sup> November 2023	Agenda Item 5	<a href="#">Budget monitoring m6 2023/24</a>	<a href="#">Link to Correspondence</a> (pages 7-10)
Wednesday 22 <sup>nd</sup> November 2023	Agenda Item 4	<a href="#">Cardiff Public Services Board</a>	<a href="#">Link to Correspondence</a> (pages 3-6)
Wednesday 13 <sup>th</sup> December 2023	Minute No. 44	<a href="#">Mid-year Performance Assessment 2023/24</a>	<a href="#">Link to Correspondence</a> (pages 3-6)

## Scrutiny Work Programmes

Committee Date	Agenda/ Minute No	Item Background Papers	Latest Published Work Programme
Tuesday 17 <sup>th</sup> October 2023	Minute No. 25	<a href="#">Children and Young People Scrutiny Committee</a>	<a href="#">Committee Business Report – CYPSC Work Programme 2023/24</a>
Monday 18 <sup>th</sup> September 2023	Minute No. 14	<a href="#">Community &amp; Adult Services Scrutiny Committee</a>	<a href="#">Work Programme 2023/24</a>
Tuesday 21 <sup>st</sup> November 2023	Minute No. 51	<a href="#">Economy &amp; Culture Scrutiny Committee</a>	<a href="#">Work Programme Update</a>
Thursday 6 <sup>th</sup> July 2023	Minute No. 17	<a href="#">Environmental Scrutiny Committee</a>	<a href="#">Committee Business Work Programming Planning 2023/24</a>
Wednesday 20 <sup>th</sup> September 2023	Minute No. 24	<a href="#">Policy Review and Performance Scrutiny Committee</a>	<a href="#">Work Programming 2023/24</a>

1. Current Work Programme 2023/24:

Area	Tuesday 11.07.23 (1pm)	Tuesday 26.09.23 (4.30pm) POSTPONED	Tuesday 24.10.23 (2pm)	Tuesday 28.11.23 (2pm)	Tuesday 23.01.24 (4:30pm)	Tuesday 26.03.24 (2pm)	Tuesday 09.07.24 (2pm) TBC
Audit Wales (AW)	Annual Audit Plan 2023			Cardiff Council - Detailed Audit Plan 2023			Annual Audit Plan 2024
	Cardiff & Vale Pension Fund Audit Plan 2023		* ISA 260 and Audited Statement of Accounts 2022/23 for Cardiff & Vale of Glamorgan Pension Fund			* ISA 260 and Audited Statement of Accounts 2022/23 for Cardiff Council including Cardiff Harbour Authority & Trust Funds	Cardiff & Vale Pension Fund Audit Plan 2024
	Annual Audit Summary Report		Cardiff & Vale Pension Fund – Detailed Audit Plan 2023		Digital and Performance Information Reports		Annual Audit Summary Report
	AW Work Programme and Timetable Update		AW Work Programme and Timetable Update		AW Work Programme and Timetable Update		AW Work Programme and Timetable Update
Performance	Draft Year-End Annual Well-being (Self-Assessment) Report 2022/23				Mid-Year Self-Assessment Report Update		Draft Year-End Annual Well-being (Self-Assessment) Report 2023/24
			Council Complaints and Compliments – Arrangements and Annual Report 2022/23		Council Complaints – Mid Year Report		
Treasury Management			Treasury Management Annual Report	Half Year Report		Draft Treasury Management Strategy 2024/25 Treasury Management Practices	
Finance	Financial Update including Resilience Issues		Financial Update including Resilience Issues	Financial Update including Resilience Issues	Financial Update including Resilience Issues	Financial Update including Resilience Issues	Financial Update including Resilience Issues
	Draft Statement of Accounts 2022/23					Statement of Accounts 2023/24: Accounting Policies and Timescales	Draft Statement of Accounts 2023/24
Internal Audit	Audit and Investigation Team - Progress Update			Audit and Investigation Team - Progress Update	Audit and Investigation Team - Progress Update	Audit and Investigation Team - Progress Update	Audit and Investigation Team - Progress Update
	Internal Audit Annual Report 2022/23		Counter-Fraud Annual Report 2022/23	Counter-Fraud and Corruption Strategy and Operational Policies - Update	Draft Internal Audit Charter & Summary Audit Plan 2024/25	Audit Charter and Audit Plan 2024/25	Internal Audit Annual Report 2023/24
Governance and Risk Management	Governance and Audit Committee Annual Report 2022/23						Governance and Audit Committee Annual Report 2023/24
	Governance Senior Management Assurance Statement 2022/23						Draft Annual Governance Statement 2023/24
	Corporate Risk Management (Year-End)			Corporate Risk Management 2023/24 (Mid-Year)	Draft Annual Governance Statement 2022/23	Corporate Risk Management (Q3)	Corporate Risk Management (Year-End)
			Recommendation Tracker – Reports of External Review Bodies			Recommendation Tracker – Reports of External Review Bodies	
Senior Officer Updates (Operational Matters / Key Risks / Other)	Update on the Council's Control Environment			Sarah McGill – Update on Directorate Control Environment (People & Communities)	Andrew Gregory – Update on Directorate Control Environment (Planning, Transport and Environment)	TBC - Neil Hanratty – Update on Directorate Control Environment (Economic Development)	TBC - Chief Executive – Update on the Council's Control Environment

Page 299

2. Matters to be addressed outside of formal Committee meetings during 2023/24:

Governance and Audit Committee

- Annual self-assessment workshop
- Training and development sessions.

General

- Correspondence, publications and reports for information purposes
- Time sensitive consultation.

Director / Senior Officer Assurance

- Use of letters, correspondence, and video / telephone meetings as necessary.

\* Timing of item could be deferred, subject to completion of external audit

This page is intentionally left blank



**GOVERNANCE & AUDIT COMMITTEE: 23 January 2024**

---

**TERMS OF REFERENCE - WASTE MANAGEMENT POST TRIAL REVIEW****REPORT OF THE CORPORATE DIRECTOR RESOURCES****AGENDA ITEM: 14**

---

**Reason for this Report**

1. The Terms of Reference of the Governance and Audit Committee requires (amongst other matters) that Members:
  - Consider reports on the effectiveness of internal controls and monitor the implementation of agreed actions.
  - Review the assessment of fraud risks and potential harm to the Council from fraud and corruption.
  - Monitor the Counter-fraud strategy, actions and resources.

**Background**

2. The Governance and Audit Committee received a confidential post trial [update](#) in November 2023, relating to a large-scale investigation in the Waste Management Service. This followed sentencing which took place on 9 November 2023 at Swansea Crown Court, in respect of five individuals (four former council workers and a third party) who were convicted of Bribery Act offences relating to the waste management service.
3. The confidential briefing provided details of:
  - Internal and police referrals, associated investigations, and outcomes.
  - Asset recovery proceedings being sought by the prosecution and the Council for the loss resulting from the offence.
  - Assurance and advisory work of the Internal Audit Team which has supported the improvement of controls.
  - The interventions that were put in place immediately following arrests.
4. The Committee had previously been advised that a Post-Trial Review would be completed and led by the Section 151 Officer (Corporate Director - Resources). In the November meeting, it was advised that the Terms of Reference for this review would be prepared by the Section 151 Officer with the engagement of the Monitoring Officer for Committee consideration on 23 January 2024.

## Issues

5. **Appendix A** contains the proposed Terms of Reference for the Waste Management Post Trial Review, for the consideration of the Governance and Audit Committee. This includes background details, the high-level scope, the detailed assurance objectives, and an outline of the approach, reporting and quality review arrangements.
6. Whilst the criminal case referred to in the background of this report was a trigger for this review, the proposed purpose of the review is to provide current assurance on the effectiveness of systems in place to mitigate the risk of fraud, bribery and corruption within the waste management service more widely.

## Legal Implications

7. In considering this matter, the Committee should ensure it is satisfied that the draft Terms of Reference for the proposed review are sufficiently clear and comprehensive to assist the Committee to discharge its responsibilities in relation to assessing the adequacy of the Council's governance, risk and control arrangements, specifically, the responsibilities set out in paragraph 2 of the report.

## Financial Implications

8. There are no direct financial implications arising from this report.

## RECOMMENDATIONS

9. That the Governance and Audit Committee considers and comments on the draft Terms of Reference for the Post Trial Review in Waste Management (Appendix A) and receives a further report once this review has concluded.

**CHRIS LEE**  
**CORPORATE DIRECTOR RESOURCES**

January 2024

The following are attached:

**Appendix A - Terms of Reference – Waste Management Post Trial Review**

**TERMS OF REFERENCE  
WASTE MANAGEMENT POST TRIAL REVIEW**

**BACKGROUND**

A post trial review has been arranged following the criminal conviction and sentencing in November 2023 of five individuals (four former council workers and a third party) of Bribery Act offences relating to the waste management service.

The review will be undertaken by Chris Lee, Corporate Director Resources (Section 151 Officer) commencing in February 2024.

Reference to ‘fraud’ within this terms of reference is to be interpreted as any matter of fraud, bribery, corruption, or other financial impropriety.

**SCOPE**

The overall purpose of the review is to seek assurance on the effectiveness of systems in place to mitigate the risk of fraud, bribery and corruption within the waste management service. Whilst the criminal case referred to in the background was a trigger for the review, the scope of this review is not limited to the issues identified through this case.

**OBJECTIVES**

The objectives of the review are to seek assurance on the:

- a) Effectiveness of the Corporate response, to the concerns of criminal activity relating to the operation of weighbridge facilities (investigation and assurance).
- b) Counter-fraud control environment within the waste management service, represented by the management approach, activities and assurances, and the deployment and independent assurances of the internal audit service.
- c) Level of fraud awareness across the waste management service, and the extent to which key vulnerabilities are known and mitigated.
- d) Effectiveness of systems in place to prevent, detect and address fraud across the waste management service.
- e) Effectiveness of arrangements to investigate concerns of potential fraud.
- f) Lessons learned from cases of fraud within waste management.

Where it is considered that improvements can be made in respect of any of the objectives of this review, observations and recommendations will be reported so that controls can be enhanced.

**APPROACH**

The review will be undertaken through:

- 1) A series of interviews with responsible management and audit representatives.

- 2) Engagement with and evidence from wider support functions, such as those leading on human resources, risk management and counter-fraud.
- 3) Examination of evidence to support the opinions and assertions made in respect of each of the audit objectives from responsible officers.

## **REPORTING**

A report will be prepared to outline the findings, observations and any recommendations arising from the review. Responsible management will be required to respond to the draft report.

The report and management response will be reported to the Governance and Audit Committee in July 2024 for Committee consideration.

## **QUALITY REVIEW**

The Monitoring Officer will review the working papers and draft report to provide assurance of the lawfulness and fairness of the review process and the findings, observations and recommendations as set out in the draft report, prior to the draft report being issued.

**GOVERNANCE & AUDIT COMMITTEE: 23 January 2024**

---

**WASTE MANAGEMENT – CONFIDENTIAL UPDATE****REPORT OF THE CORPORATE DIRECTOR RESOURCES****AGENDA ITEM: 15**

---

***Appendix A to this report is not for publication as it contains exempt information of the description in Paragraphs 14, 18 & 21 of Schedule 12A of the Local Government Act 1972.***

**Reason for this Report**

1. To provide the Committee with an update on a confidential investigation within Waste Management.
2. The Terms of Reference of the Governance and Audit Committee requires that Members:
  - Consider reports on the effectiveness of internal controls and monitor the implementation of agreed actions.
  - Review the assessment of fraud risks and potential harm to the Council from fraud and corruption.
  - Monitor the Counter-fraud strategy, actions and resources.

**Background**

3. This update follows previous information provided to Committee, which is contained within the attached appendix.

**Issues**

4. Appendix A provides background information and an update on a confidential investigation within Waste Management.
5. Due to ongoing proceedings, the update is to be treated as confidential and is provided for the information of the Governance and Audit Committee.

### **Legal Implications**

6. There are no direct legal implications arising from the recommendations of the report.

### **Financial Implications**

7. There are no direct financial implications arising from this report.

### **RECOMMENDATIONS**

That the Governance and Audit Committee considers and notes the confidential update contained in Appendix A.

**CHRIS LEE**  
**CORPORATE DIRECTOR RESOURCES**

The following are attached:

**Appendix A – Confidential Update**

By virtue of paragraph(s) 14, 18, 21 of Part(s) 4 and 5 of Schedule 12A of the Local Government Act 1972.

Document is Restricted

This page is intentionally left blank